

How to use this manual

A Few Words About Safety

Service Information

The service and repair information contained in this manual is intended for use by qualified, professional technicians.

Attempting service or repairs without the proper training, tools, and equipment could cause injury to you or others. It could also damage the vehicle or create an unsafe condition.

This manual describes the proper methods and procedures for performing service, maintenance and repairs. Some procedures require the use of specially designed tools and dedicated equipment. Any person who intends to use a replacement part, service procedure or a tool that is not recommended by Honda, must determine the risks to their personal safety and the safe operation of the vehicle.

If you need to replace a part, use genuine Honda parts with the correct part number or an equivalent part. We strongly recommend that you do not use replacement parts of inferior quality.

For Your Customer's Safety

Proper service and maintenance are essential to the customer's safety and the reliability of the vehicle. Any error or oversight while servicing a vehicle can result in faulty operation, damage to the vehicle, or injury to others.

⚠ WARNING

Improper service or repairs can create an unsafe condition that can cause your customer to be seriously hurt or killed.

Follow the procedures and precautions in this manual and other service materials carefully.

For Your Safety

Because this manual is intended for the professional service technician, we do not provide warnings about many basic shop safety practices (e.g., Hot parts—wear gloves). If you have not received shop safety training or do not feel confident about your knowledge of safe servicing practice, we recommended that you do not attempt to perform the procedures described in this manual.

Some of the most important general service safety precautions are given below. However, we cannot warn you of every conceivable hazard that can arise in performing service and repair procedures. Only you can decide whether or not you should perform a given task.

⚠ WARNING

Failure to properly follow instructions and precautions can cause you to be seriously hurt or killed.

Follow the procedures and precautions in this manual carefully.

Important Safety Precautions

Make sure you have a clear understanding of all basic shop safety practices and that you are wearing appropriate clothing and using safety equipment. When performing any service task, be especially careful of the following:

- Read all of the instructions before you begin, and make sure you have the tools, the replacement or repair parts, and the skills required to perform the tasks safely and completely.
- Protect your eyes by using proper safety glasses, goggles or face shields any time you hammer, drill, grind, pry or work around pressurized air or liquids, and springs or other stored-energy components. If there is any doubt, put on eye protection.
- Use other protective wear when necessary, for example gloves or safety shoes. Handling hot or sharp parts can cause severe burns or cuts. Before you grab something that looks like it can hurt you, stop and put on gloves.
- Protect yourself and others whenever you have the vehicle up in the air. Any time you lift the vehicle, either with a hoist or a jack, make sure that it is always securely supported. Use jack stands.

Make sure the engine is off before you begin any servicing procedures, unless the instruction tells you to do otherwise. This will help eliminate several potential hazards:

- Carbon monoxide poisoning from engine exhaust. Be sure there is adequate ventilation whenever you run the engine
- Burns from hot parts or coolant. Let the engine and exhaust system cool before working in those areas.
- Injury from moving parts. If the instruction tells you to run the engine, be sure your hands, fingers and clothing are out of the way.

Gasoline vapors and hydrogen gases from batteries are explosive. To reduce the possibility of a fire or explosion, be careful when working around gasoline or batteries.

- Use only a nonflammable solvent, not gasoline, to clean parts.
 - Never drain or store gasoline in an open container.
 - Keep all cigarettes, sparks and flames away from the battery and all fuel-related parts.
-

How To Use This Manual

This manual describes the service procedures for the XR125LK/LEK and XL125LK.

Sections 1 and 3 apply to the whole vehicle. Section 2 illustrates procedures for removal/installation of components that may be required to perform service described in the following sections.

Section 4 through 19 describe parts of the motorcycle, grouped according to location.

Follow the Maintenance Schedule recommendations to ensure that the vehicle is in peak operating condition.

Performing the first scheduled maintenance is very important. It compensates for the initial wear that occurs during the break-in period.

Find the section you want on this page, then turn to the table of contents on the first page of the section.

Most sections start with an assembly or system illustration, service information and troubleshooting for the section. The subsequent pages give detailed procedure.

Refer to the troubleshooting in each section according to the malfunction or symptom.

Your safety, and the safety of others, is very important. To help you make informed decisions we have provided safety messages and other information throughout this manual. Of course, it is not practical or possible to warn you about all the hazards associated with servicing this vehicle.

You must use your own good judgement.

You will find important safety information in a variety of forms including:

- Safety Labels – on the vehicle
- Safety Messages – preceded by a safety alert symbol  and one of three signal words, DANGER, WARNING, or CAUTION. These signal words mean:

 DANGER You WILL be KILLED or SERIOUSLY HURT if you don't follow instructions.

 WARNING You CAN be KILLED or SERIOUSLY HURT if you don't follow instructions.

 CAUTION You CAN be HURT if you don't follow instructions.

- Instructions – how to service this vehicle correctly and safely.

As you read this manual, you will find information that is preceded by a **NOTICE** symbol. The purpose of this message is to help prevent damage to your vehicle, other property, or the environment.

ALL INFORMATION, ILLUSTRATIONS, DIRECTIONS AND SPECIFICATIONS INCLUDED IN THIS PUBLICATION ARE BASED ON THE LATEST PRODUCT INFORMATION AVAILABLE AT THE TIME OF APPROVAL FOR PRINTING. Honda Motor Co., Ltd. RESERVES THE RIGHT TO MAKE CHANGES AT ANY TIME WITHOUT NOTICE AND WITHOUT INCURRING ANY OBLIGATION WHATSOEVER. NO PART OF THIS PUBLICATION MAY BE REPRODUCED WITHOUT WRITTEN PERMISSION. THIS MANUAL IS WRITTEN FOR PERSONS WHO HAVE ACQUIRED BASIC KNOWLEDGE OF MAINTENANCE ON Honda MOTORCYCLES, MOTOR SCOOTERS OR ATVS.











© Honda Motor Co., Ltd.
SERVICE PUBLICATION OFFICE

Date of Issue: May, 2012

How to use this manual

SYMBOLS

The symbols used throughout this manual show specific service procedures. If supplementary information is required pertaining to these symbols, it would be explained specifically in the text without the use of the symbols.

	Replace the part(s) with new one(s) before assembly.
	Use the recommend engine oil, unless otherwise specified.
	Use molybdenum oil solution (mixture of the engine oil and molybdenum grease in a ratio of 1:1).
	Use multi-purpose grease (lithium based multi-purpose grease NLGI #2 or equivalent).
	Use molybdenum disulfide grease (containing more than 3% molybdenum disulfide, NLGI #2 or equivalent). Example: <ul style="list-style-type: none">• Molykote® BR-2 plus manufactured by Dow Corning U.S.A.• Multi-purpose M-2 manufactured by Mitsubishi Oil, Japan
	Use molybdenum disulfide paste (containing more than 40% molybdenum disulfide, NLGI #2 or equivalent). Example: <ul style="list-style-type: none">• Molykote® G-n Paste manufactured by Dow Corning U.S.A.• Honda Moly 60 (U.S.A. only)• Rocol ASP manufactured by Rocol Limited, U.K.• Rocol Paste manufactured by Sumico Lubricant, Japan
	Use silicone grease.
	Apply a locking agent. Use a medium strength locking agent unless otherwise specified.
	Apply sealant.
	Use DOT 3 or DOT 4 brake fluid. Use the recommended brake fluid unless otherwise specified.
	Use fork or suspension fluid.

CONTENTS

	GENERAL INFORMATION	1
	FRAME/BODY PANELS/EXHAUST SYSTEM	2
	MAINTENANCE	3
ENGINE/DRIVE TRAIN ELECTRICAL	IGNITION SYSTEM	4
	ELECTRIC STARTER	5
	FUEL SYSTEM	6
	LUBRICATION SYSTEM	7
	CYLINDER HEAD/VALVES	8
	CYLINDER/PISTON	9
	CLUTCH/GEARSHIFT LINKAGE	10
	ALTERNATOR/STARTER CLUTCH	11
	CRANKSHAFT/TRANSMISSION/KICKSTARTER	12
	ENGINE REMOVAL/INSTALLATION	13
	CHASSIS	FRONT WHEEL/BRAKE/SUSPENSION/STEERING
REAR WHEEL/BRAKE/SUSPENSION		15
HYDRAULIC BRAKE (XR125LK/LEK)		16
FRAME ELECTRICAL	BATTERY/CHARGING SYSTEM	17
	LIGHTS/METER/SWITCHES	18
	WIRING DIAGRAMS	19
	INDEX	

MEMO

1. GENERAL INFORMATION

SERVICE RULES	1-2	LUBRICATION & SEAL POINTS	1-14
MODEL IDENTIFICATION	1-2	CABLE & HARNESS ROUTING (XR125LK/ LEK)	1-16
SPECIFICATIONS	1-3	CABLE & HARNESS ROUTING (XL125LK)--	1-24
TORQUE VALUES	1-10	EMISSION CONTROL SYSTEMS	1-30

GENERAL INFORMATION

SERVICE RULES

1. Use genuine Honda or Honda-recommended parts and lubricants or their equivalents. Parts that do not meet Honda's design specifications may cause damage to the motorcycle.
2. Use the special tools designed for this product to avoid damage and incorrect assembly.
3. Use only metric tools when servicing the motorcycle. Metric bolts, nuts and screws are not interchangeable with English fasteners.
4. Install new gaskets, O-rings, cotter pins, and lock plates when reassembling.
5. When tightening bolts or nuts, begin with the larger diameter or inner bolt first. Then tighten to the specified torque diagonally in incremental steps unless a particular sequence is specified.
6. Clean parts in cleaning solvent upon disassembly. Lubricate any sliding surfaces before reassembly.
7. After reassembly, check all parts for proper installation and operation.
8. Route all electrical wires as show in the Cable and Harness Routing (page 1-24).
9. Do not bend or twist control cables. Damaged control cables will not operate smoothly and may stick or bind.

MODEL IDENTIFICATION

This manual covers following types of XR125 and XL125 models; be sure to refer to the procedure for the appropriate version.

MODEL	CODE	REGION	WHEEL SIZE (Front/Rear)	Kickstarter	Electric starter	Air cut-off valve	Carburetor heater	Sidestand switch
XR125LK	DK	Common export	19/17 in	O	—	O	O	—
	III LA	Latin America	19/17 in	O	—	O	—	—
XR125LEK	DK	Common export	19/17 in	O	O	O	O	—
	III LA	Latin America	19/17 in	O	O	O	—	—
	CO	Colombia	19/17 in	O	O	O	—	—
	NZ	New Zealand	19/17 in	O	O	O	O	O
	I LA	Latin America	19/17 in	O	O	O	O	—
XL125LK	II DK	Common export	21/18 in	O	—	—	O	—

XR125LEK shown:

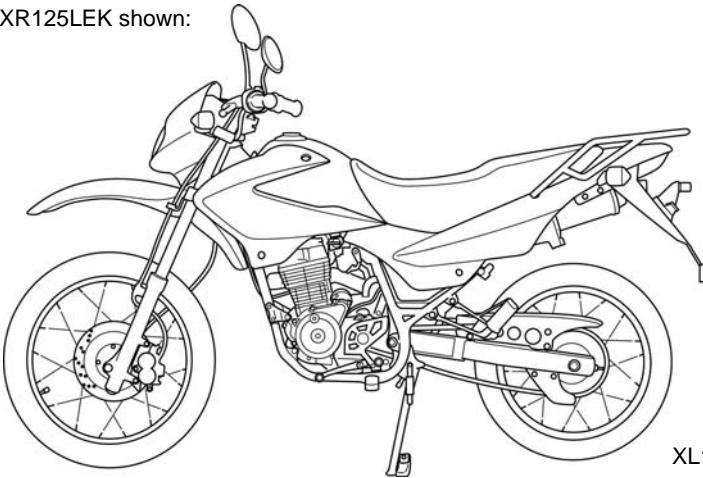

XL125LK shown:

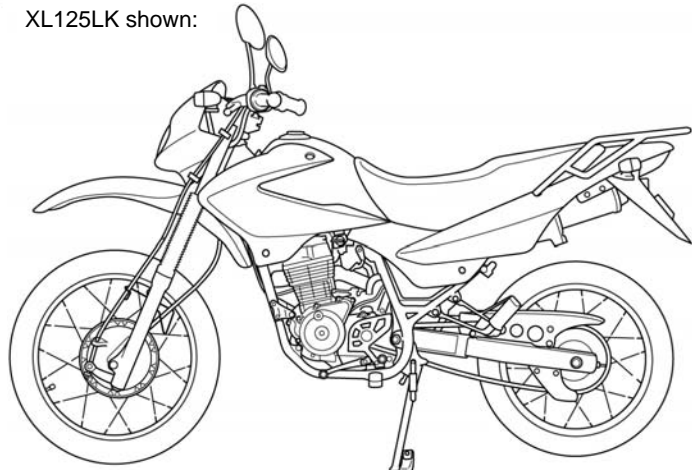

The frame serial number [1] is stamped on the right side of the steering head.



The carburetor identification number [1] is stamped on the right side of the carburetor body.

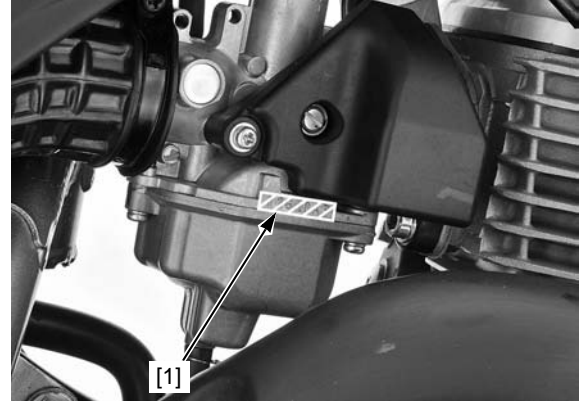

The engine serial number [1] is stamped on the lower left side of the crankcase.

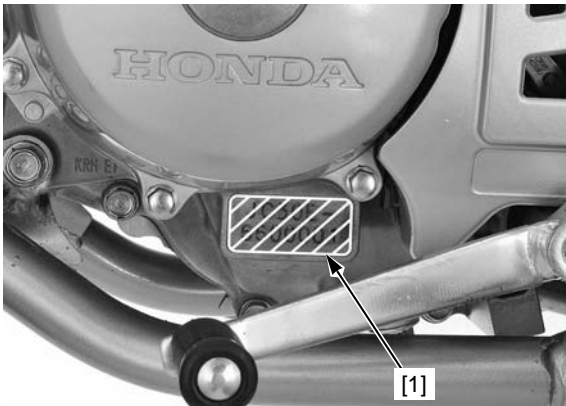

The color label [1] is attached as shown. When ordering color-coded parts, always specify the designated color code.

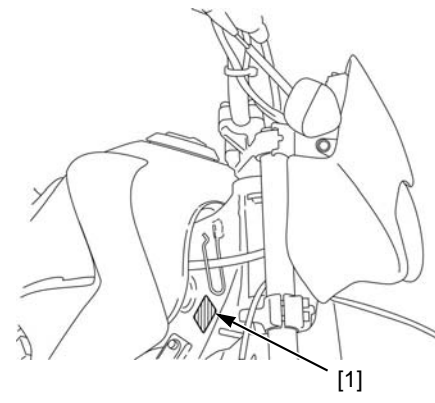

SPECIFICATIONS

GENERAL SPECIFICATIONS

ITEM		SPECIFICATION
DIMENSIONS (XR125LK/LEK)	Overall length	2,100 mm (82.7 in)
	Overall width	820 mm (32.3 in)
	Overall height	1,126 mm (44.3 in)
	Wheelbase	1,361 mm (53.6 in)
	Seat height	825 mm (32.5 in)
	Ground clearance	243 mm (9.6 in)
	Dry weight	119 kg (262 lbs)
	Curb weight	129 kg (284 lbs)
	Maximum weight capacity	159 kg (351 lbs)
	DIMENSIONS (XL125LK)	Overall length
Overall width		827 mm (32.6 in)
Overall height		1,147 mm (45.2 in)
Wheelbase		1,360 mm (53.5 in)
Seat height		849 mm (33.4 in)
Ground clearance		265 mm (10.4 in)
Dry weight		113.5 kg (250.2 lbs)
Curb weight		122.6 kg (270.3 lbs)
Maximum weight capacity		159 kg (351 lbs)

GENERAL INFORMATION

ITEM		SPECIFICATION
FRAME (XR125LK/LEK)	Frame type Front suspension Front wheel travel Rear suspension Rear wheel travel Front tire size Rear tire size Front tire brand Rear tire brand Front brake Rear brake Caster angle Trail length Fuel tank capacity Fuel tank reserve capacity	Semi double cradle Telescopic fork 160 mm (6.3 in) Swingarm 151 mm (5.9 in) 90/90 – 19 M/C 52P 110/90 – 17 M/C 60P C6559F (CHENG SHIN) C6559 (CHENG SHIN) Hydraulic single disc Mechanical leading trailing 27° 104 mm (4.1 in) 12.0 liter (3.17 US gal, 2.64 Imp gal) 3.5 liter (0.92 US gal, 0.77 Imp gal)
FRAME (XL125LK)	Frame type Front suspension Front wheel travel Rear suspension Rear wheel travel Front tire size Rear tire size Front tire brand Rear tire brand Front brake Rear brake Caster angle Trail length Fuel tank capacity Fuel tank reserve capacity	Semi double cradle Telescopic fork 159 mm (6.3 in) Swingarm 148 mm (5.8 in) 70/100 – 21 M/C 44P 100/90 – 18 M/C 56P CM-704 (CHENG SHIN) CM-705 (CHENG SHIN) Mechanical leading trailing Mechanical leading trailing 26.9° 104 mm (4.1 in) 12.0 liter (3.17 US gal, 2.64 Imp gal) 3.5 liter (0.92 US gal, 0.77 Imp gal)
ENGINE	Bore and stroke Displacement Valve train Compression ratio Intake valve opens at 1 mm (0.04 in) lift closes at 1 mm (0.04 in) lift Exhaust valve opens at 1 mm (0.04 in) lift closes at 1 mm (0.04 in) lift Lubrication system Oil pump type Cooling system Air filtration Engine dry weight	52.4 x 57.8 mm (2.06 x 2.28 in) 124.7 cm ³ (7.61 cu-in) Chain driven, OHC 2-valve with rocker arm 9.2 : 1 5° BTDC 30° ABDC 30° BBDC 0° TDC Forced pressure and wet sump Trochoid Air cooled Paper element (Viscous type) XR125LK/LEK: 28.5 kg (62.8 lbs) XL125LK: 26.6 kg (58.6 lbs)
CARBURETOR	Carburetor type Throttle bore	Piston valve 20 mm (0.8 in)
DRIVE TRAIN	Clutch system Clutch operation system Transmission Primary reduction Final reduction Gear ratio Gearshift pattern	Multi-plate, wet Cable operating Constant mesh, 5-speeds 3.350 (67/20) 3.187 (51/16) 2.785 (39/14) 1.875 (30/16) 1.409 (31/22) 1.120 (28/25) 0.937 (30/32) Left foot operated return system 1 - N - 2 - 3 - 4 - 5

GENERAL INFORMATION

ITEM		SPECIFICATION
ELECTRICAL	Ignition system	DC-CDI Kickstarter Electric starter motor with kickstarter Single phase output alternator SCR shorted, single phase half-wave rectification Alternator
	Starting system	
	Charging system	
	Regulator/rectifier	
	Lighting system	

IGNITION SYSTEM SPECIFICATIONS

ITEM		SPECIFICATIONS
Spark plug	Standard	CPR7EA-9 (NGK)
	For extended high speed riding	CPR8EA-9 (NGK)
Spark plug gap		0.80 – 0.90 mm (0.031 – 0.035 in)
Ignition coil primary peak voltage		100 V minimum
Ignition pulse generator peak voltage		0.7 V minimum
Ignition timing ("F" mark)		8° BTDC at idle

ELECTRIC STARTER SPECIFICATION

Unit: mm (in)

ITEM	STANDARD	SERVICE LIMIT
Starter motor brush length	10.00 – 10.05 (0.394 – 0.396)	6.5 (0.26)

LUBRICATION SYSTEM SPECIFICATIONS

Unit: mm (in)

ITEM		STANDARD	SERVICE LIMIT
Engine oil capacity	After draining	1.0 liter (1.1 US qt, 0.9 Imp qt)	–
	After disassembly	1.2 liter (1.3 US qt, 1.1 Imp qt)	–
Recommended engine oil		Honda "4-stroke motorcycle oil" or an equivalent motor oil API service classification: SG or higher (except oils labeled as energy conserving on the circular API service label) Viscosity: SAE 10W-30 JASO T 903 standard: MA	–
Oil pump rotor	Tip clearance	0.15 (0.006)	0.20 (0.008)
	Body clearance	0.15 – 0.21 (0.006 – 0.008)	0.25 (0.010)
	Side clearance	0.05 – 0.10 (0.002 – 0.004)	0.12 (0.005)

FUEL SYSTEM SPECIFICATIONS

ITEM		SPECIFICATIONS
Carburetor identification number	DK, NZ, I LA types	PDN2H
	III LA type	PDN2J
	CO type	PDN2K
	XL125LK (II DK type)	PDN2G
Main jet		#98
Slow jet		#38
Pilot screw initial opening	XR125LK/LEK	See page 6-12
	XL125LK	See page 6-13
Float level		14 mm (0.6 in)
Carburetor heater resistance (except III LA, CO types)		8.2 – 12.3 Ω (25°C/77°F)
PAIR control valve specified vacuum (XR125LK/LEK)		330 mm Hg
Idle speed		1,500 ± 100 min ⁻¹ (rpm)
Throttle grip free play		2.0 – 6.0 mm (0.08 – 0.24 in)

GENERAL INFORMATION

CYLINDER HEAD/VALVES SPECIFICATIONS

Unit: mm (in)

ITEM		STANDARD		SERVICE LIMIT
Cylinder compression at 300 min ⁻¹ (rpm)		1,275 kPa (13.0 kgf/cm ² , 185 psi)		–
Valve clearance		IN	0.08 ± 0.02 (0.003 ± 0.001)	–
		EX	0.12 ± 0.02 (0.005 ± 0.001)	–
Valve, valve guide	Valve stem O.D.	IN	4.975 – 4.990 (0.1959 – 0.1965)	4.92 (0.194)
		EX	4.955 – 4.970 (0.1951 – 0.1957)	4.90 (0.193)
	Valve guide I.D.	IN/EX	5.000 – 5.012 (0.1969 – 0.1973)	5.04 (0.198)
	Stem-to-guide clearance	IN	0.010 – 0.037 (0.0004 – 0.0015)	0.07 (0.003)
		EX	0.030 – 0.057 (0.0012 – 0.0022)	0.09 (0.004)
Valve seat width	IN/EX	0.9 – 1.1 (0.035 – 0.043)	1.5 (0.06)	
Valve spring	Free length	INNER	38.76 (1.526)	37.89 (1.492)
		OUTER	35.95 (1.415)	35.14 (1.383)
Rocker arm	Arm I.D.	IN/EX	10.000 – 10.015 (0.3937 – 0.3943)	10.10 (0.398)
	Shaft O.D.	IN/EX	9.972 – 9.987 (0.3926 – 0.3932)	9.91 (0.390)
	Arm-to-shaft clearance	IN/EX	0.013 – 0.043 (0.0005 – 0.0017)	0.10 (0.004)
Camshaft	Cam lobe height	IN	32.9935 – 33.2335 (1.29895 – 1.30840)	32.96 (1.298)
		EX	32.8804 – 33.1204 (1.29450 – 1.30395)	32.85 (1.293)
Cylinder head warpage		–		0.05 (0.002)

CYLINDER/PISTON SPECIFICATIONS

Unit: mm (in)

ITEM		STANDARD		SERVICE LIMIT	
Cylinder	I.D.	52.400 – 52.410 (2.0630 – 2.0634)		52.50 (2.067)	
	Out-of-round	–		0.10 (0.004)	
	Taper	–		0.10 (0.004)	
	Warpage	–		0.10 (0.004)	
Piston, piston pin, piston ring	Piston O.D. at 10 mm (0.4 in) from bottom		52.370 – 52.390 (2.0618 – 2.0626)		52.3 (2.059)
	Piston pin hole I.D.		13.002 – 13.008 (0.5119 – 0.5121)		13.04 (0.513)
	Piston pin O.D.		12.994 – 13.000 (0.5116 – 0.5118)		12.96 (0.510)
	Piston-to-piston pin clearance		0.002 – 0.014 (0.0001 – 0.0006)		0.02 (0.001)
	Piston ring end gap	Top	0.10 – 0.25 (0.004 – 0.010)		0.40 (0.016)
		Second	0.10 – 0.25 (0.004 – 0.010)		0.40 (0.016)
		Oil (side rail)	0.20 – 0.70 (0.008 – 0.028)		0.85 (0.033)
	Piston ring-to-ring groove clearance	Top	0.030 – 0.065 (0.0012 – 0.0026)		0.10 (0.004)
Second		0.030 – 0.065 (0.0012 – 0.0026)		0.10 (0.004)	
Cylinder-to-piston clearance		0.010 – 0.040 (0.0004 – 0.0016)		0.10 (0.004)	
Connecting rod small end I.D.		13.016 – 13.034 (0.5124 – 0.5131)		13.04 (0.513)	
Connecting rod-to-piston pin clearance		0.016 – 0.034 (0.0006 – 0.0013)		0.10 (0.004)	

CLUTCH/GEARSHIFT LINKAGE SPECIFICATIONS

Unit: mm (in)

ITEM		STANDARD		SERVICE LIMIT	
Clutch lever free play		10 – 20 (0.4 – 0.8)		–	
Clutch	Spring free length		40.5 (1.59)		39.6 (1.56)
	Disc thickness	Disc A	2.80 – 2.90 (0.110 – 0.114)		2.6 (0.10)
		Disc B	2.80 – 2.90 (0.110 – 0.114)		2.6 (0.10)
	Plate warpage		–		0.20 (0.008)
Clutch outer I.D.		23.000 – 23.021 (0.9055 – 0.9063)		23.08 (0.909)	
Clutch outer guide	O.D.	22.959 – 22.980 (0.9039 – 0.9047)		22.93 (0.903)	
	I.D.	16.991 – 17.009 (0.6689 – 0.6696)		17.04 (0.671)	
Mainshaft O.D. at clutch outer guide		16.966 – 16.984 (0.6680 – 0.6687)		16.95 (0.667)	
Kickstarter idle gear I.D.		20.500 – 20.521 (0.8071 – 0.8079)		20.58 (0.810)	
Kickstarter idle gear bushing	O.D.	20.459 – 20.480 (0.8055 – 0.8063)		20.43 (0.804)	
	I.D.	17.000 – 17.018 (0.6693 – 0.6700)		17.04 (0.671)	
Countershaft O.D. at kickstarter idle gear		16.966 – 16.984 (0.6680 – 0.6687)		16.94 (0.667)	
Kickstarter drive gear I.D.		16.016 – 16.034 (0.6305 – 0.6313)		16.06 (0.632)	
Kickstarter spindle O.D. at kickstarter drive gear		15.966 – 15.984 (0.6286 – 0.6293)		15.94 (0.628)	

ALTERNATOR/STARTER CLUTCH SPECIFICATION

Unit: mm (in)

ITEM	STANDARD	SERVICE LIMIT
Starter driven gear boss O.D.	45.660 – 45.673 (1.7976 – 1.7981)	45.60 (1.795)

CRANKCASE/CRANKSHAFT/TRANSMISSION SPECIFICATIONS

Unit: mm (in)

ITEM		STANDARD	SERVICE LIMIT	
Crankshaft	Connecting rod big end radial clearance	0 – 0.008 (0 – 0.0003)	0.05 (0.002)	
	Connecting rod big end side clearance	0.10 – 0.35 (0.004 – 0.014)	0.80 (0.032)	
	Runout	0.03 (0.001)	0.08 (0.003)	
Transmission	Gear I.D.	M4	20.000 – 20.018 (0.7874 – 0.7881)	20.04 (0.789)
		M5	17.000 – 17.018 (0.6693 – 0.6700)	17.04 (0.671)
		C1	20.500 – 20.521 (0.8071 – 0.8079)	20.55 (0.809)
		C2	23.020 – 23.041 (0.9063 – 0.9071)	23.07 (0.908)
		C3	23.025 – 23.046 (0.9065 – 0.9073)	23.07 (0.908)
	Bushing O.D.	C1	20.459 – 20.480 (0.8055 – 0.8063)	20.41 (0.804)
		C2	22.984 – 23.005 (0.9049 – 0.9057)	22.95 (0.904)
		C3	22.984 – 23.005 (0.9049 – 0.9057)	22.95 (0.904)
	Bushing I.D.	C1	17.000 – 17.018 (0.6693 – 0.6700)	17.04 (0.671)
		C2	20.020 – 20.041 (0.7882 – 0.7890)	20.07 (0.790)
		C3	20.020 – 20.041 (0.7882 – 0.7890)	20.07 (0.790)
	Gear-to-bushing clearance	C1	0.020 – 0.062 (0.0008 – 0.0024)	0.10 (0.004)
		C2	0.015 – 0.057 (0.0006 – 0.0022)	0.10 (0.004)
		C3	0.020 – 0.062 (0.0008 – 0.0024)	0.10 (0.004)
	Mainshaft O.D.	at M4	19.968 – 19.980 (0.7861 – 0.7866)	19.93 (0.785)
		at M5	16.968 – 16.980 (0.6680 – 0.6685)	16.93 (0.667)
	Countershaft O.D.	at C1	16.966 – 16.984 (0.6680 – 0.6687)	16.93 (0.667)
		at C2	19.978 – 19.989 (0.7865 – 0.7870)	19.94 (0.785)
		at C3	19.979 – 20.000 (0.7866 – 0.7874)	19.94 (0.785)
	Gear-to-shaft clearance	M4	0.020 – 0.050 (0.0008 – 0.0020)	0.10 (0.004)
		M5	0.020 – 0.050 (0.0008 – 0.0020)	0.10 (0.004)
Bushing-to-shaft clearance	C1	0.016 – 0.052 (0.0006 – 0.0020)	0.10 (0.004)	
	C2	0.031 – 0.063 (0.0012 – 0.0025)	0.10 (0.004)	
	C3	0.020 – 0.062 (0.0008 – 0.0024)	0.10 (0.004)	
Shift fork, shift fork shaft	Shift fork shaft O.D.	9.986 – 9.995 (0.3931 – 0.3944)	9.93 (0.391)	
	Shift fork I.D.	10.000 – 10.018 (0.3937 – 0.3944)	10.05 (0.396)	
	Shift fork claw thickness	4.93 – 5.00 (0.194 – 0.197)	4.50 (0.177)	

FRONT WHEEL/SUSPENSION/STEERING SPECIFICATIONS (XR125LK/LEK)

Unit: mm (in)

ITEM		STANDARD	SERVICE LIMIT
Minimum tire thread depth		–	3.0 (0.12)
Cold tire pressure	Driver only	150 kPa (1.50 kgf/cm ² , 22 psi)	–
	Driver and passenger	150 kPa (1.50 kgf/cm ² , 22 psi)	–
Axle runout		–	0.20 (0.008)
Wheel rim runout	Radial	–	2.0 (0.08)
	Axial	–	2.0 (0.08)
Fork	Spring free length	594.5 (23.41)	582.6 (22.94)
	Pipe runout	–	0.20 (0.008)
	Recommended fluid	Honda ULTRA CUSHION OIL 10W or equivalent	–
	Fluid level	179 (7.0)	–
	Fluid capacity	180 ± 2.5 cm ³ (6.1 ± 0.08 US oz, 6.3 ± 0.09 Imp oz)	–
Steering head bearing pre-load		11.8 – 17.7 N (1.2 – 1.8 kgf, 2.6 – 4.0 lbf)	–

GENERAL INFORMATION

FRONT WHEEL/BRAKE/SUSPENSION/STEERING SPECIFICATIONS (XL125LK)

Unit: mm (in)

ITEM		STANDARD	SERVICE LIMIT
Minimum tire thread depth		–	3.0 (0.12)
Cold tire pressure	Driver only	150 kPa (1.50 kgf/cm ² , 22 psi)	–
	Driver and passenger	150 kPa (1.50 kgf/cm ² , 22 psi)	–
Axle runout		–	0.20 (0.008)
Wheel rim runout	Radial	–	2.0 (0.08)
	Axial	–	2.0 (0.08)
Fork	Spring free length	605.5 (23.84)	593.4 (23.36)
	Pipe runout	–	0.20 (0.008)
	Recommended fluid	Honda ULTRA CUSHION OIL 10W or equivalent	–
	Fluid level	194 (7.6)	–
	Fluid capacity	180 ± 2.5 cm ³ (6.1 ± 0.08 US oz, 6.3 ± 0.09 Imp oz)	–
Brake	Drum I.D.	130 (5.1)	131 (5.2)
	Brake lever free play	10 – 20 (0.4 – 0.8)	–
Steering head bearing pre-load		11.8 – 17.7 N (1.2 – 1.8 kgf, 2.6 – 4.0 lbf)	–

REAR WHEEL/BRAKE/SUSPENSION SPECIFICATIONS

Unit: mm (in)

ITEM		STANDARD	SERVICE LIMIT
Minimum tire thread depth		–	3.0 (0.12)
Cold tire pressure	XR125LK/ LEK	Driver only	150 kPa (1.50 kgf/cm ² , 22 psi)
		Driver and passenger	200 kPa (2.00 kgf/cm ² , 29 psi)
	XL125LK	Driver only	150 kPa (1.50 kgf/cm ² , 22 psi)
		Driver and passenger	225 kPa (2.25 kgf/cm ² , 33 psi)
Axle runout		–	0.20 (0.008)
Wheel rim runout	Radial	–	2.0 (0.08)
	Axial	–	2.0 (0.08)
Drive chain	Size/link	428/130	–
	Slack	20 – 30 (0.8 – 1.2)	–
Brake	Drum I.D.	110 (4.3)	111 (4.4)
	Brake pedal free play	15 – 25 (0.6 – 1.0)	–

HYDRAULIC BRAKE SPECIFICATIONS (XR125LK/LEK)

Unit: mm (in)

ITEM	STANDARD	SERVICE LIMIT
Specified brake fluid	DOT 3 or DOT 4	–
Brake pad wear indicator	–	To groove
Brake disc thickness	4.0 (0.16)	3.5 (0.14)
Brake disc runout	–	0.25 (0.010)
Master cylinder I.D.	12.700 – 12.743 (0.5000 – 0.5017)	12.755 (0.5022)
Master piston O.D.	12.657 – 12.684 (0.4983 – 0.4994)	12.645 (0.4978)
Caliper cylinder I.D.	27.000 – 27.050 (1.0630 – 1.0650)	27.060 (1.0654)
Caliper piston O.D.	26.918 – 26.968 (1.0598 – 1.0617)	26.91 (1.059)

BATTERY/CHARGING SYSTEM SPECIFICATIONS

ITEM			SPECIFICATIONS
Battery	Type	XL125LK, XR125LK	YTX4L-BS
		XR125LEK	YTX5L-BS
	Capacity	XL125LK, XR125LK	12 V – 3 Ah (10 HR)
		XR125LEK	12 V – 4 Ah (10 HR)
	Current leakage		0.01 mA max.
	Voltage (20°C/68°F)	Fully charged	Above 12.8 V
		Needs charging	Below 12.3 V
	Charging current	XL125LK, XR125LK	Normal
Quick			4.0 A/0.5 h
XR125LEK		Normal	0.5 A/5 – 10 h
		Quick	5.0 A/0.5 h
Alternator	Capacity	0.12 kW/5,000 min ⁻¹ (rpm)	
	Charging coil resistance (20°C/68°F)		0.2 – 1.2 Ω

LIGHTS/METER/SWITCHES SPECIFICATIONS

ITEM			SPECIFICATIONS
Bulbs	Headlight (High/Low beam)		12 V – 35/35 W
	Position light		12 V – 4 W
	Brake/taillight		12 V – 21/5 W
	License light (XR125LK/LEK)		12 V – 5 W
	Front turn signal light	XR125LK/LEK	12 V – 16 W x 2
		XL125LK	12 V – 15 W x 2
	Rear turn signal light	XR125LK/LEK	12 V – 16 W x 2
		XL125LK	12 V – 15 W x 2
	Instrument light		12 V – 1.7 W
	Turn signal indicator		12 V – 3.4 W
	High beam indicator		12 V – 3.4 W
Neutral indicator		12 V – 3.4 W	
Fuse	Main fuse		15 A
	Sub fuse		10 A

GENERAL INFORMATION

TORQUE VALUES

STANDARD TORQUE VALUES

FASTENER TYPE	TORQUE N-m (kgf-m, lbf-ft)	FASTENER TYPE	TORQUE N-m (kgf-m, lbf-ft)
5 mm hex bolt and nut	5.2 (0.5, 3.8)	5 mm screw	4.2 (0.4, 3.1)
6 mm hex bolt and nut (Include SH flange bolt)	10 (1.0, 7)	6 mm screw	9.0 (0.9, 6.6)
8 mm hex bolt and nut	22 (2.2, 16)	6 mm flange bolt (Include NSHF) and nut	12 (1.2, 9)
10 mm hex bolt and nut	34 (3.5, 25)	8 mm flange bolt and nut	27 (2.8, 20)
12 mm hex bolt and nut	54 (5.5, 40)	10 mm flange bolt and nut	39 (4.0, 29)

ENGINE & FRAME TORQUE VALUES

FRAME/BODY PANELS/EXHAUST SYSTEM

ITEM	Q'TY	THREAD DIA. (mm)	TORQUE N-m (kgf-m, lbf-ft)	REMARKS
Exhaust pipe joint nut	2	8	18 (1.8, 13)	See page 2-6
Exhaust pipe protector bolt	2	6	14 (1.4, 10)	
Muffler rear mounting nut	2	8	26 (2.7, 19)	
Muffler front mounting bolt	2	8	26 (2.7, 19)	
Muffler band bolt	1	8	20 (2.0, 15)	
Exhaust pipe stud bolt	2	8	11 (1.1, 8)	

MAINTENANCE

ITEM	Q'TY	THREAD DIA. (mm)	TORQUE N-m (kgf-m, lbf-ft)	REMARKS
Air cleaner case cover screw	4	5	1.1 (0.1, 0.8)	Apply engine oil to the threads and seating surface.
Air cleaner element screw	4	5	1.1 (0.1, 0.8)	
Spark plug	1	10	16 (1.6, 12)	
Valve adjusting lock nut	2	6	14 (1.4, 10)	
Crankshaft hole cap	1	32	15 (1.5, 11)	Apply grease to the threads.
Timing hole cap	1	14	10 (1.0, 7)	
Engine oil drain bolt	1	12	30 (3.1, 22)	
Oil filter rotor cover screw	3	5	4.0 (0.4, 3.0)	
Rear axle nut	1	16	93 (9.5, 69)	U-nut
Drive sprocket fixing plate bolt	2	6	12 (1.2, 9)	
Driven sprocket nut	6	10	32 (3.3, 24)	U-nut
Sidestand pivot bolt	1	10	10 (1.0, 7)	
Sidestand pivot nut	1	10	39 (4.0, 29)	U-nut
Front spoke	36	BC3.2	3.7 (0.4, 2.7)	
Rear spoke	36	BC3.2	3.7 (0.4, 2.7)	

IGNITION SYSTEM

ITEM	Q'TY	THREAD DIA. (mm)	TORQUE N-m (kgf-m, lbf-ft)	REMARKS
Timing hole cap	1	14	10 (1.0, 7)	

ELECTRIC STARTER (XR125LEK)

ITEM	Q'TY	THREAD DIA. (mm)	TORQUE N-m (kgf-m, lbf-ft)	REMARKS
Starter motor case bolt	2	6	10 (1.0, 7)	

FUEL SYSTEM

ITEM	Q'TY	THREAD DIA. (mm)	TORQUE N-m (kgf-m, lbf-ft)	REMARKS
Carburetor drain screw	1	6	1.5 (0.2, 1.1)	
Carburetor heater (DK, II DK, I LA, NZ types)	1	8	4.9 (0.5, 3.6)	
Choke lever set plate screw	1	4	2.1 (0.2, 1.5)	
Slow jet	1	6	1.8 (0.2, 1.3)	
Needle jet holder	1	7	2.5 (0.3, 1.8)	
Main jet	1	5	2.1 (0.2, 1.5)	
Float chamber screw	3	4	2.1 (0.2, 1.5)	
Air cut-off valve cover screw (XR125LK/LEK)	2	4	2.1 (0.2, 1.5)	
Fuel valve	1	18	27 (2.8, 20)	
Insulator socket bolt	2	6	12 (1.2, 9)	
Shock absorber lower mounting nut	1	10	44 (4.5, 32)	U-nut

LUBRICATION SYSTEM

ITEM	Q'TY	THREAD DIA. (mm)	TORQUE N-m (kgf-m, lbf-ft)	REMARKS
Oil pump cover screw	1	4	3.0 (0.3, 2.2)	

CYLINDER HEAD/VALVES

ITEM	Q'TY	THREAD DIA. (mm)	TORQUE N-m (kgf-m, lbf-ft)	REMARKS
Rocker arm shaft bolt	2	5	5.0 (0.5, 3.7)	
Cylinder head cover bolt	2	6	10 (1.0, 7)	
Cam sprocket bolt	2	5	9.0 (0.9, 6.6)	Apply engine oil to the threads and seating surface.
Tensioner lifter sealing plug	1	6	4.0 (0.4, 3.0)	
Camshaft holder special nut	4	8	32 (3.3, 24)	Apply engine oil to the threads and seating surface.
Timing hole cap	1	14	10 (1.0, 7)	Apply grease to the threads.
Crankshaft hole cap	1	32	15 (1.5, 11)	
Spark plug	1	10	16 (1.6, 12)	

CYLINDER/PISTON

ITEM	Q'TY	THREAD DIA. (mm)	TORQUE N-m (kgf-m, lbf-ft)	REMARKS
Cylinder stud bolt	4	8	11 (1.1, 8)	See page 9-5

CLUTCH/GEARSHIFT LINKAGE

ITEM	Q'TY	THREAD DIA. (mm)	TORQUE N-m (kgf-m, lbf-ft)	REMARKS
Clutch center lock nut	1	14	74 (7.5, 55)	Apply engine oil to the threads and seating surface.
Clutch lifter plate bolt	4	6	12 (1.2, 9)	
Oil filter rotor lock nut	1	14	64 (6.5, 47)	Apply engine oil to the threads and seating surface.
Oil filter rotor cover screw	3	5	4.0 (0.4, 3.0)	
Gearshift cam bolt	1	6	12 (1.2, 9)	Apply locking agent to the threads. Coating width: 6.5 ± 1.0 mm (0.26 ± 0.04 in) from tip
Shift drum stopper arm bolt	1	6	12 (1.2, 9)	Apply locking agent to the threads. Coating width: 6.5 ± 1.0 mm (0.26 ± 0.04 in) from tip
Gearshift spindle return spring pin	1	8	22 (2.2, 16)	Apply locking agent to the threads. Coating width: 6.5 ± 1.0 mm (0.26 ± 0.04 in) from tip
Gearshift pedal pinch bolt	1	6	12 (1.2, 9)	
Kickstarter arm bolt	1	8	26 (2.7, 19)	

GENERAL INFORMATION

ALTERNATOR/STARTER CLUTCH

ITEM	Q'TY	THREAD DIA. (mm)	TORQUE N-m (kgf-m, lbf-ft)	REMARKS
Flywheel nut	1	12	74 (7.5, 55)	Apply engine oil to the threads and seating surface.
Starter clutch bolt	6	6	16 (1.6, 12)	Apply locking agent to the threads. Coating width: 6.5 ± 1.0 mm (0.26 ± 0.04 in) from tip
Stator mounting bolt	3	6	12 (1.2, 9)	
Ignition pulse generator mounting bolt	2	6	12 (1.2, 9)	Apply locking agent to the threads. Coating width: 6.5 ± 1.0 mm (0.26 ± 0.04 in) from tip
Alternator stator wire guide bolt	1	6	12 (1.2, 9)	Apply locking agent to the threads. Coating width: 6.5 ± 1.0 mm (0.26 ± 0.04 in) from tip

CRANKSHAFT/TRANSMISSION/KICKSTARTER

ITEM	Q'TY	THREAD DIA. (mm)	TORQUE N-m (kgf-m, lbf-ft)	REMARKS
Mainshaft bearing setting plate bolt (Right crankcase side)	2	6	12 (1.2, 9)	Apply locking agent to the threads. Coating width: 6.5 ± 1.0 mm (0.26 ± 0.04 in) from tip
Push plug plate bolt	1	6	10 (1.0, 7)	Apply locking agent to the threads. Coating width: 6.5 ± 1.0 mm (0.26 ± 0.04 in) from tip

ENGINE REMOVAL/INSTALLATION

ITEM	Q'TY	THREAD DIA. (mm)	TORQUE N-m (kgf-m, lbf-ft)	REMARKS
Upper engine hanger plate nut	2	8	35 (3.6, 26)	
Upper engine hanger nut	1	8	35 (3.6, 26)	
Front engine hanger plate nut	2	8	35 (3.6, 26)	
Front engine hanger nut	1	8	35 (3.6, 26)	
Front lower engine hanger nut	1	8	35 (3.6, 26)	
Rear upper engine hanger nut	1	10	60 (6.1, 44)	
Rear lower engine hanger nut	1	10	60 (6.1, 44)	
Drive sprocket fixing plate bolt	2	6	12 (1.2, 9)	

FRONT WHEEL/BRAKE/SUSPENSION/STEERING

ITEM	Q'TY	THREAD DIA. (mm)	TORQUE N-m (kgf-m, lbf-ft)	REMARKS
Front axle nut	1	12	44 (4.5, 32)	U-nut
Brake disc mounting nut	5	6	15 (1.5, 11)	U-nut
Handlebar holder bolt	4	8	26 (2.7, 19)	
Fork socket bolt	2	8	20 (2.0, 15)	Apply locking agent to the threads.
Fork cap	2	27	22 (2.2, 16)	
Bottom bridge pinch bolt	4	8	32 (3.3, 24)	
Top bridge pinch bolt	2	8	22 (2.2, 16)	
Steering bearing adjustment nut	1	22	–	See page 14-25
Steering stem nut	1	22	103 (10.5, 76)	See page 14-25
Brake master cylinder holder bolt	2	6	12 (1.2, 9)	
Front brake caliper mounting bolt (XR125LK/LEK)	2	8	30 (3.1, 22)	ALOC bolt; replace with new one.
Front brake lever pivot bolt (XL125LK)	1	6	0.6 (0.1, 0.4)	
Front brake lever pivot nut (XL125LK)	1	6	5.9 (0.6, 4.4)	
Clutch lever pivot bolt	1	6	0.6 (0.1, 0.4)	
Clutch lever pivot nut	1	6	5.9 (0.6, 4.4)	
Front brake arm nut (XL125LK)	1	6	10 (1.0, 7)	
Front brake hose clamp bolt (XR125LK/LEK)	1	6	12 (1.2, 9)	

REAR WHEEL/BRAKE/SUSPENSION

ITEM	Q'TY	THREAD DIA. (mm)	TORQUE N-m (kgf-m, lbf-ft)	REMARKS
Driven sprocket nut	6	10	32 (3.3, 24)	U-nut
Rear axle nut	1	16	93 (9.5, 69)	U-nut
Rear brake arm nut	1	6	10 (1.0, 7)	U-nut
Shock absorber upper mounting bolt	1	10	44 (4.5, 32)	ALOC bolt; replace with new one.
Shock absorber lower mounting nut	1	10	44 (4.5, 32)	U-nut
Drive chain slider screw	1	5	6.0 (0.6, 4.4)	
Swingarm pivot nut	1	14	88 (9.0, 65)	U-nut

HYDRAULIC BRAKE (XR125LK/LEK)

ITEM	Q'TY	THREAD DIA. (mm)	TORQUE N-m (kgf-m, lbf-ft)	REMARKS
Master cylinder reservoir cap screw	2	4	1.5 (0.2, 1.1)	
Brake lever pivot bolt	1	6	1.0 (0.1, 0.7)	
Brake lever pivot nut	1	6	5.9 (0.6, 4.4)	
Front brake light switch screw	1	4	1.2 (0.1, 0.9)	
Brake caliper main slide pin	1	8	22 (2.2, 16)	Apply locking agent to the threads.
Brake caliper sub slide pin	1	8	12.3 (1.3, 9)	Apply locking agent to the threads.
Brake pad pin	1	10	17.2 (1.8, 13)	
Pad pin plug	1	10	2.5 (0.3, 1.8)	
Brake caliper mounting bolt	2	8	30 (3.1, 22)	ALOC bolt; replace with new one.
Caliper bleed valve	1	8	5.4 (0.6, 4.0)	
Brake hose oil bolt	2	10	34 (3.5, 25)	

GENERAL INFORMATION

LUBRICATION & SEAL POINTS

ENGINE

MATERIAL	LOCATION	REMARKS
Sealant (ThreeBond 1215 or equivalent)	Crankcase mating area	
	Alternator wire grommet seating surface	
Engine oil	Oil pump rotors	
	Oil filter rotor lock nut threads and seating surface	
	Oil through sliding area	
	Rocker arm shaft whole surface	
	Rocker arm inner surface and roller surface	
	Rocker arm valve adjusting nut threads	
	Cam chain whole surface	
	Camshaft holder special nut threads and seating surface	
	Cylinder inner surface	
	Piston sliding surface, piston pin hole and ring grooves	
	Piston ring whole surface	
	Clutch disc whole surface	
	Clutch center lock nut threads and seating surface	
	Clutch lifter arm sliding surface	
	Flywheel nut threads and seating surface	
	Gearshift spindle journal	
	Starter reduction gear shaft whole surface	
	Starter clutch rolling surface	
	Shift fork shaft whole surface	
	Shift drum journals and guide grooves	
	Gear teeth (primary, transmission, kickstarter)	
	Each bearing rotating area	
	Each O-ring	
Multi-purpose grease	Each oil seal lip	
	Crankshaft hole cap threads	
Molybdenum disulfide oil (a mixture of 1/2 engine oil and 1/2 molybdenum disulfide grease)	Valve stem sliding surface and stem end	
	Camshaft cam whole surface	
	Piston pin outer surface	
	Clutch outer guide outer surface	
	Crankshaft connecting rod big end needle bearing	Drip 1 – 2 cm ³
	Crankshaft connecting rod small end inner surface	
	Crankshaft bearing push plug whole surface	
	Right crankshaft bearing rotating surface	
	Starter driven gear inner surface	
	M4, M5, C1, C2, C3 gear inner surface	
	C1, C2, C3 gear bushing whole surface	
	M3, C4, C5 gear shift fork groove	
	Kickstarter pinion inner surface	
Kickstarter idle gear inner bushing whole surface		
Locking agent	Shift drum stopper arm bolt threads	Coating width: 6.5 ± 1.0 mm (0.26 ± 0.04 in) from tip
	Gearshift cam bolt threads	Coating width: 6.5 ± 1.0 mm (0.26 ± 0.04 in) from tip
	Starter clutch bolt threads	Coating width: 6.5 ± 1.0 mm (0.26 ± 0.04 in) from tip
	Ignition pulse generator mounting bolt threads	Coating width: 6.5 ± 1.0 mm (0.26 ± 0.04 in) from tip
	Mainshaft bearing setting plate bolt threads	Coating width: 6.5 ± 1.0 mm (0.26 ± 0.04 in) from tip
	Alternator stator wire guide bolt threads	Coating width: 6.5 ± 1.0 mm (0.26 ± 0.04 in) from tip
	Crankshaft bearing push plug bolt threads	Coating width: 6.5 ± 1.0 mm (0.26 ± 0.04 in) from tip
Degreasing	Flywheel and crankshaft contact areas	

FRAME

MATERIAL	LOCATION	REMARKS
Urea based multipurpose grease with extreme pressure agent (example: EXCELITE EP2 manufactured by Kyodo Yushi or equivalent)	Steering head bearing	Apply each 3 – 5 g
	Steering stem dust seal lips	
Grease (Daphne EPONEX No.0 or equivalent)	Front brake panel dust seal lip (XL125LK)	
	Speedometer pinion shaft (XL125LK)	Apply 0.2 – 0.3 g
	Speedometer gear inner surface (XL125LK)	Apply 0.2 – 0.3 g
	Speedometer gear teeth (XL125LK)	Apply 3 g
	Speedometer pinion dust seal lip (XL125LK)	
Grease (Daphne EPONEX No.2 or equivalent)	Speedometer gear teeth (XR125LK/LEK)	Apply 0.5 – 1.0 g
	Speedometer gear inner surface (XR125LK/LEK)	Apply 0.5 – 1.0 g
	Speedometer pinion shaft (XR125LK/LEK)	
Multi-purpose grease	Front brake cam and shaft (XL125LK)	Apply each 0.2 – 0.3 g
	Front brake panel anchor pin (XL125LK)	Apply 0.2 – 0.3 g
	Front brake cam dust seal lip (XL125LK)	
	Front brake lever pivot bolt sliding surface (XL125LK)	
	Rear brake cam and shaft	Apply each 0.2 – 0.3 g
	Rear brake panel anchor pin	Apply 0.2 – 0.3 g
	Rear brake cam dust seal lip	Apply 0.2 – 0.3 g
	Front wheel dust seal lip	
	Rear wheel dust seal lip	
	Shock absorber needle bearing	
	Shock absorber dust seal lip	
	Swingarm pivot needle bearing	
	Swingarm pivot dust seal cap lip	
	Sidestand pivot	
	Rear brake pedal pivot sliding surface	
	Throttle grip pipe cable rolling area	
	Clutch lever pivot bolt sliding surface	
	Each bearing rotating area	
Silicone grease	Brake lever pivot sliding surface (XR125LK/LEK)	
	Brake caliper pin sliding surface (XR125LK/LEK)	
	Brake caliper bracket pin sliding surface (XR125LK/LEK)	
	Brake caliper piston dust seal (XR125LK/LEK)	
	Brake lever push rod contact surface (XR125LK/LEK)	
DOT 3 or DOT 4 brake fluid	Brake master piston and cups (XR125LK/LEK)	
	Brake caliper piston seal lip (XR125LK/LEK)	
	Brake caliper piston sliding surface (XR125LK/LEK)	
Honda Bond A or equivalent	Handlebar grip inner surface	
Honda ULTRA CUSHION OIL 10W or equivalent	Fork oil seal lips	
	Fork dust seal lips	
	Fork cap O-ring	
Locking agent	Muffler protector bolt threads	
	Exhaust pipe protector bolt threads	
	Fork socket bolt threads	

GENERAL INFORMATION

CABLE & HARNESS ROUTING (XR125LK/LEK)

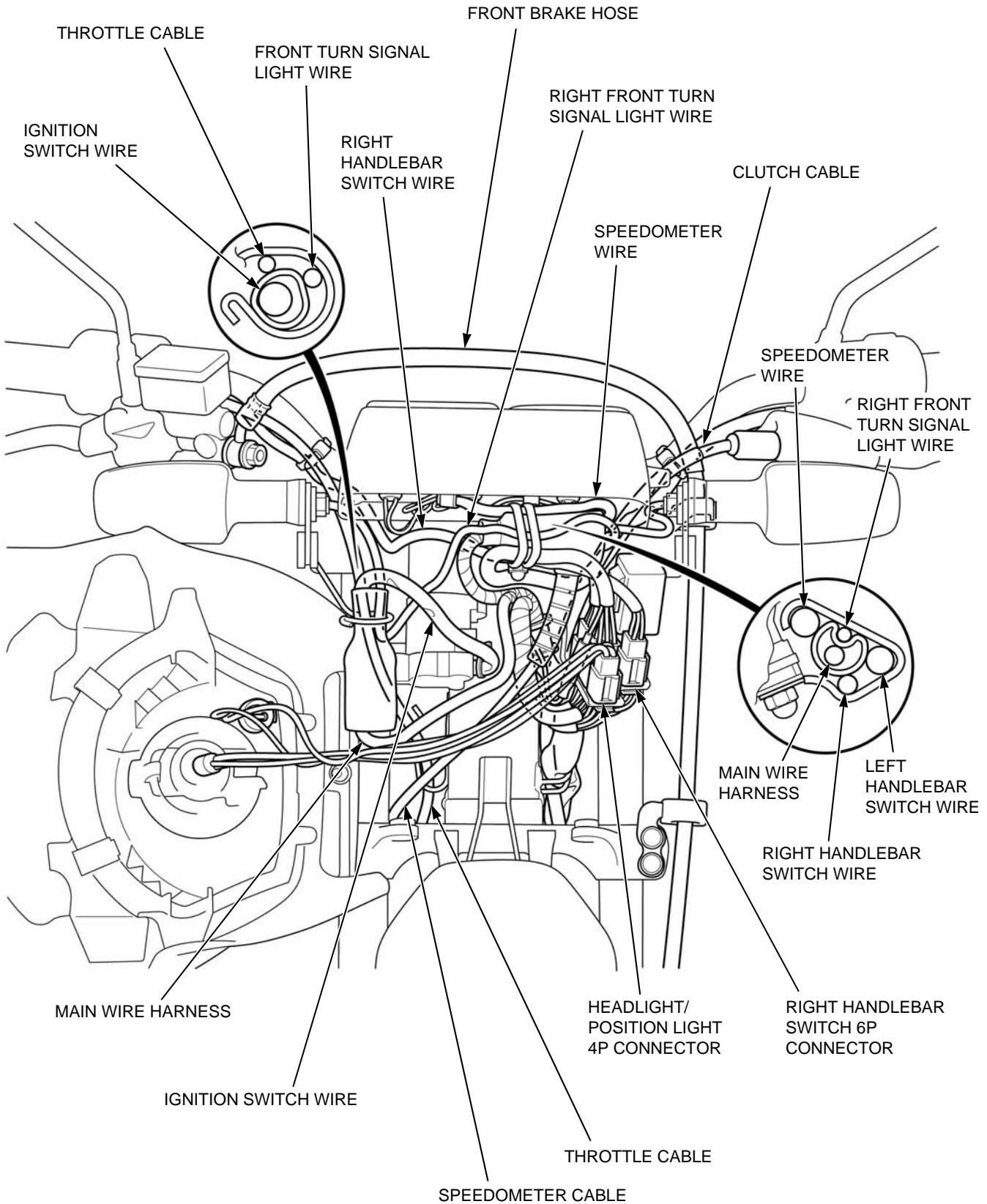

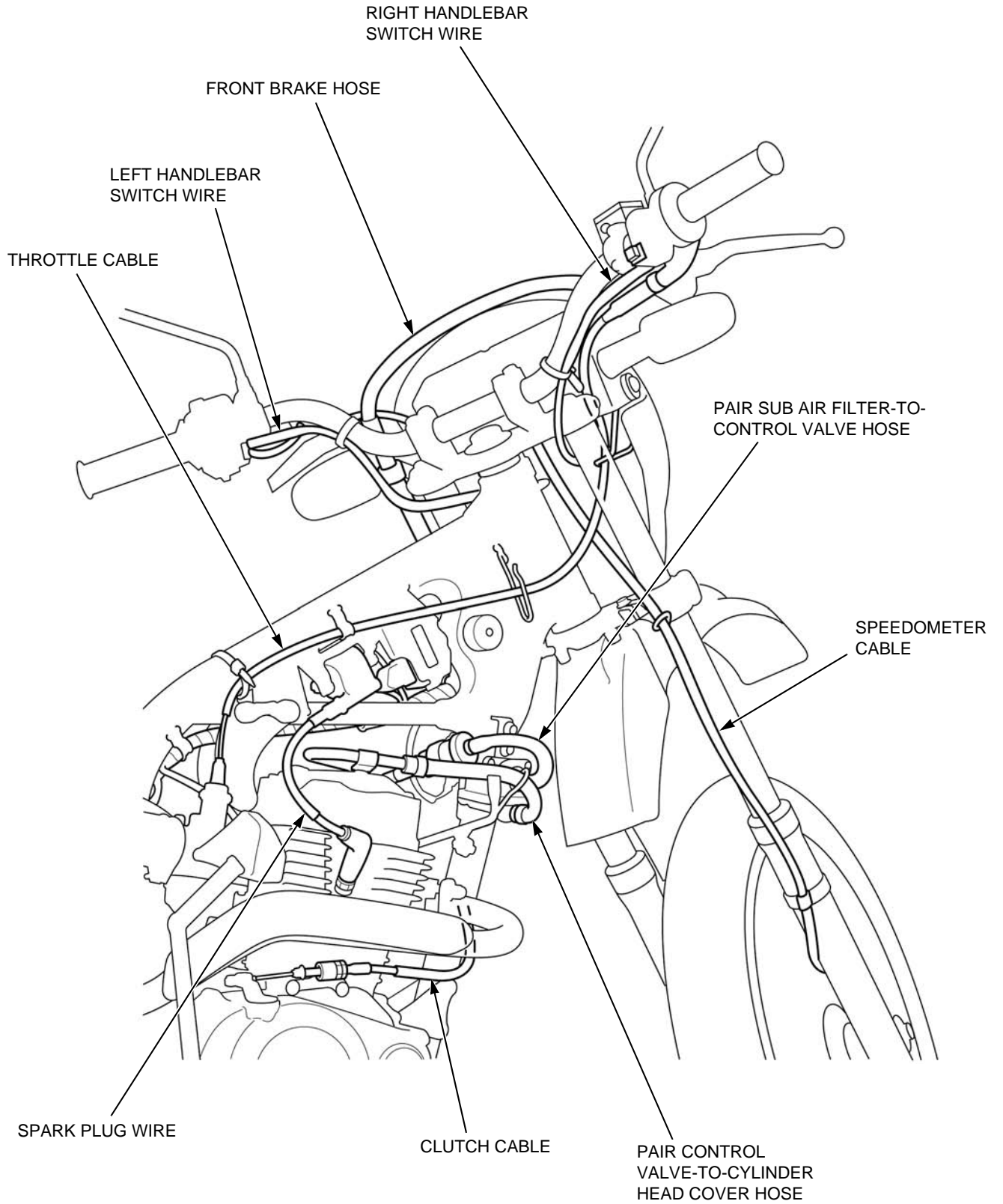

GENERAL INFORMATION

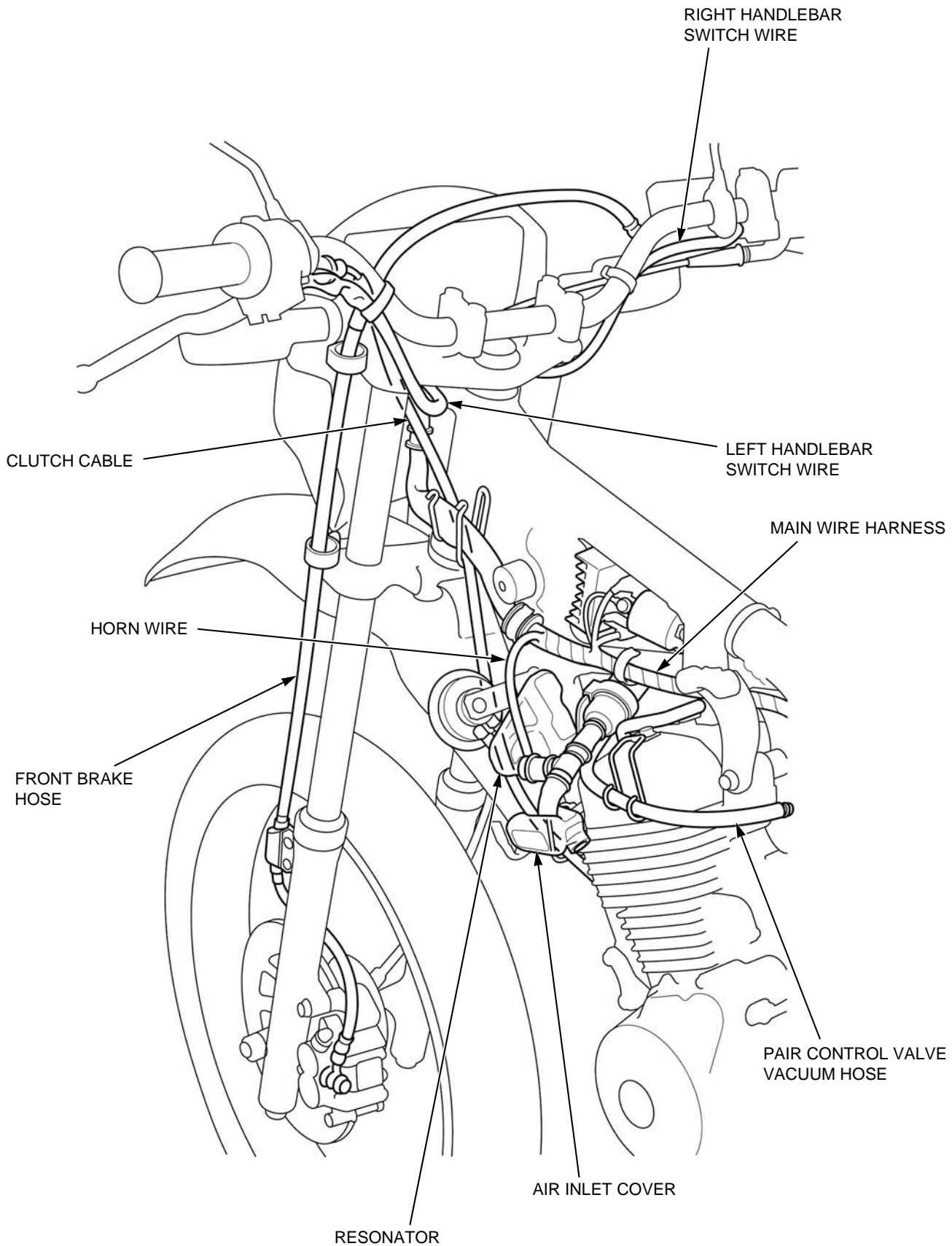

- CONNECTOR BOOT:
- NEUTRAL SWITCH WIRE CONNECTOR
- ALTERNATOR 2P CONNECTOR
- IGNITION PULSE GENERATOR WIRE CONNECTOR
- THERMO SWITCH 2P CONNECTOR (EXCEPT III LA, CO TYPES)

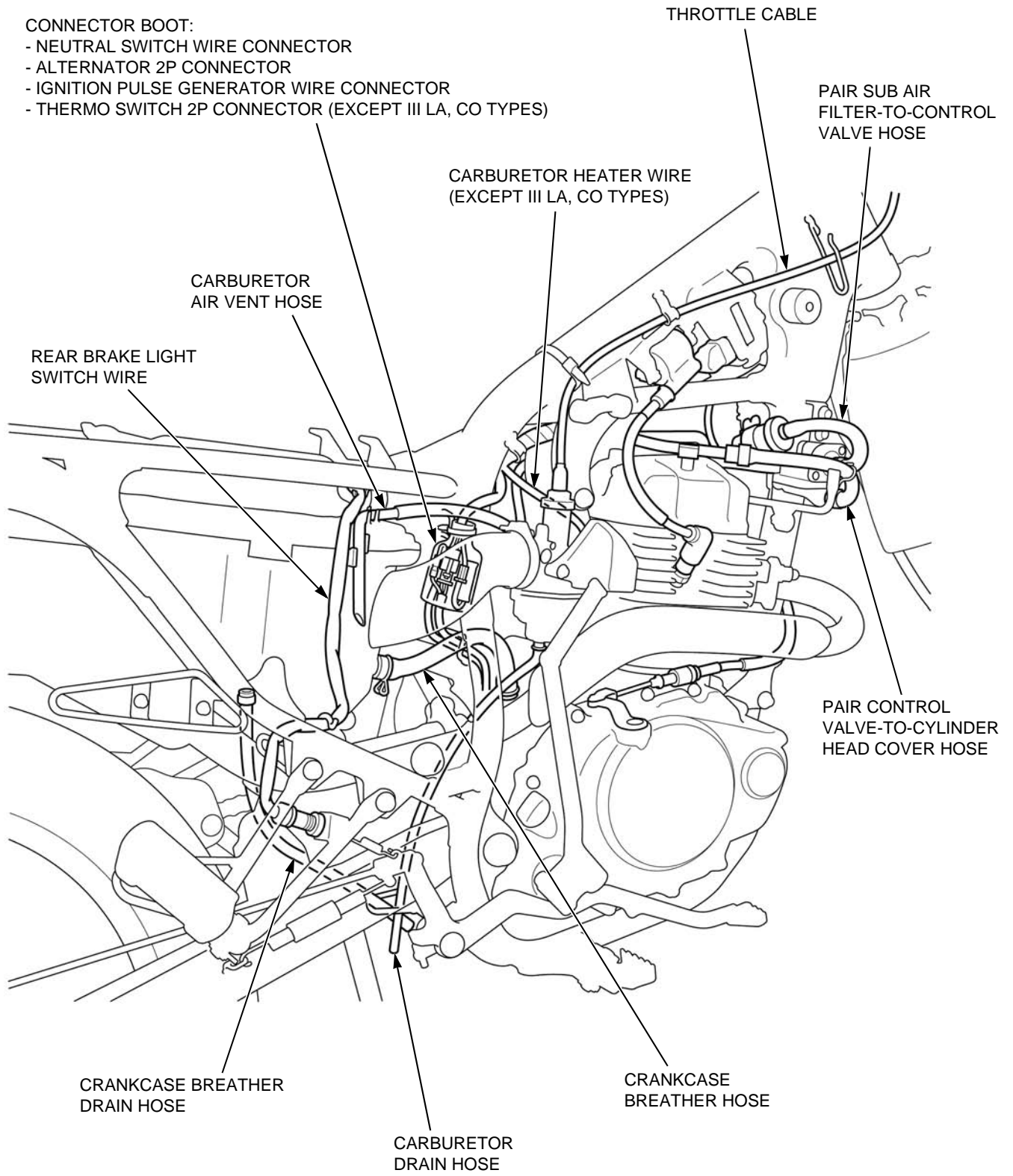

GENERAL INFORMATION

XR125LEK:

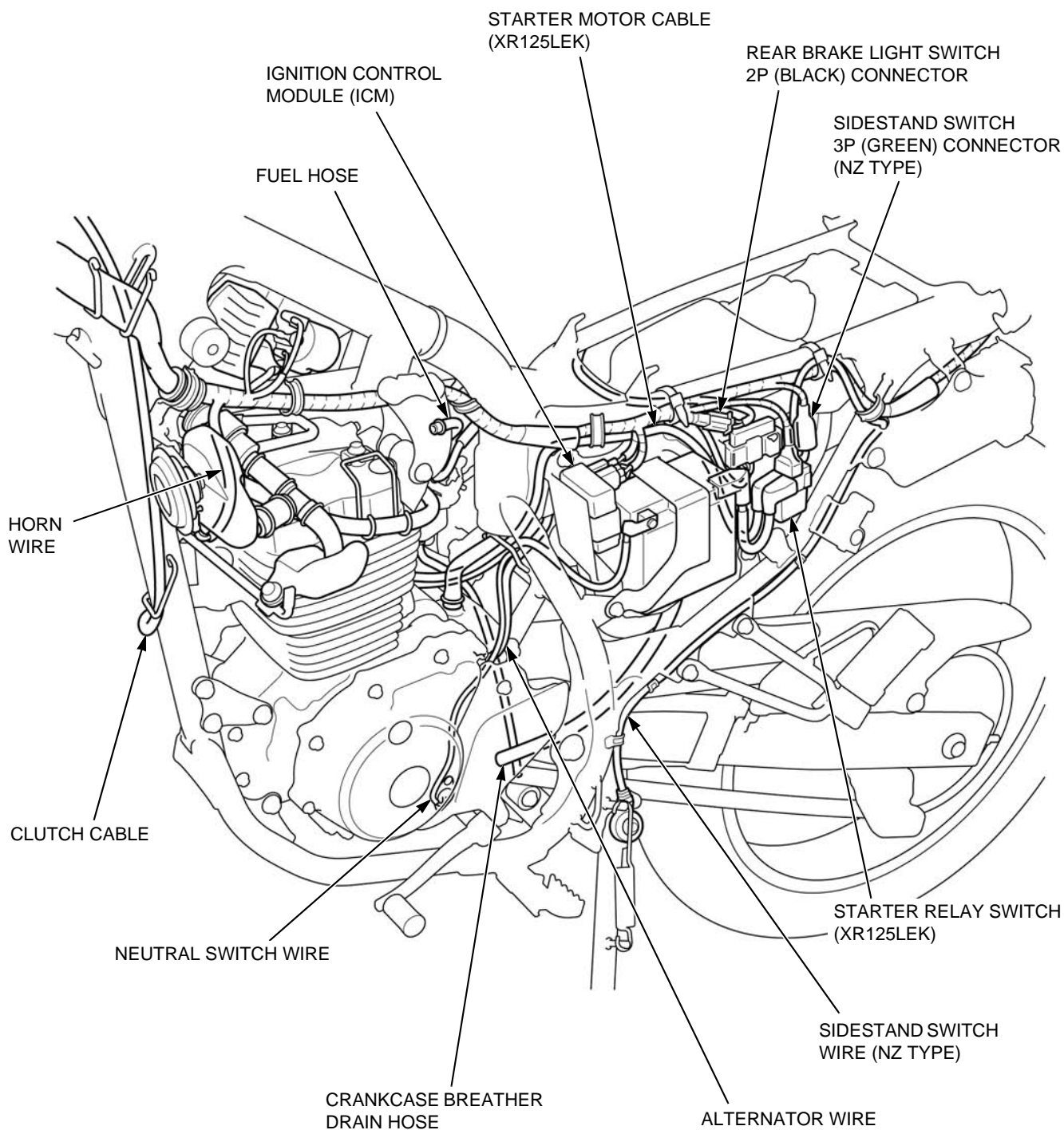

XR125LK:

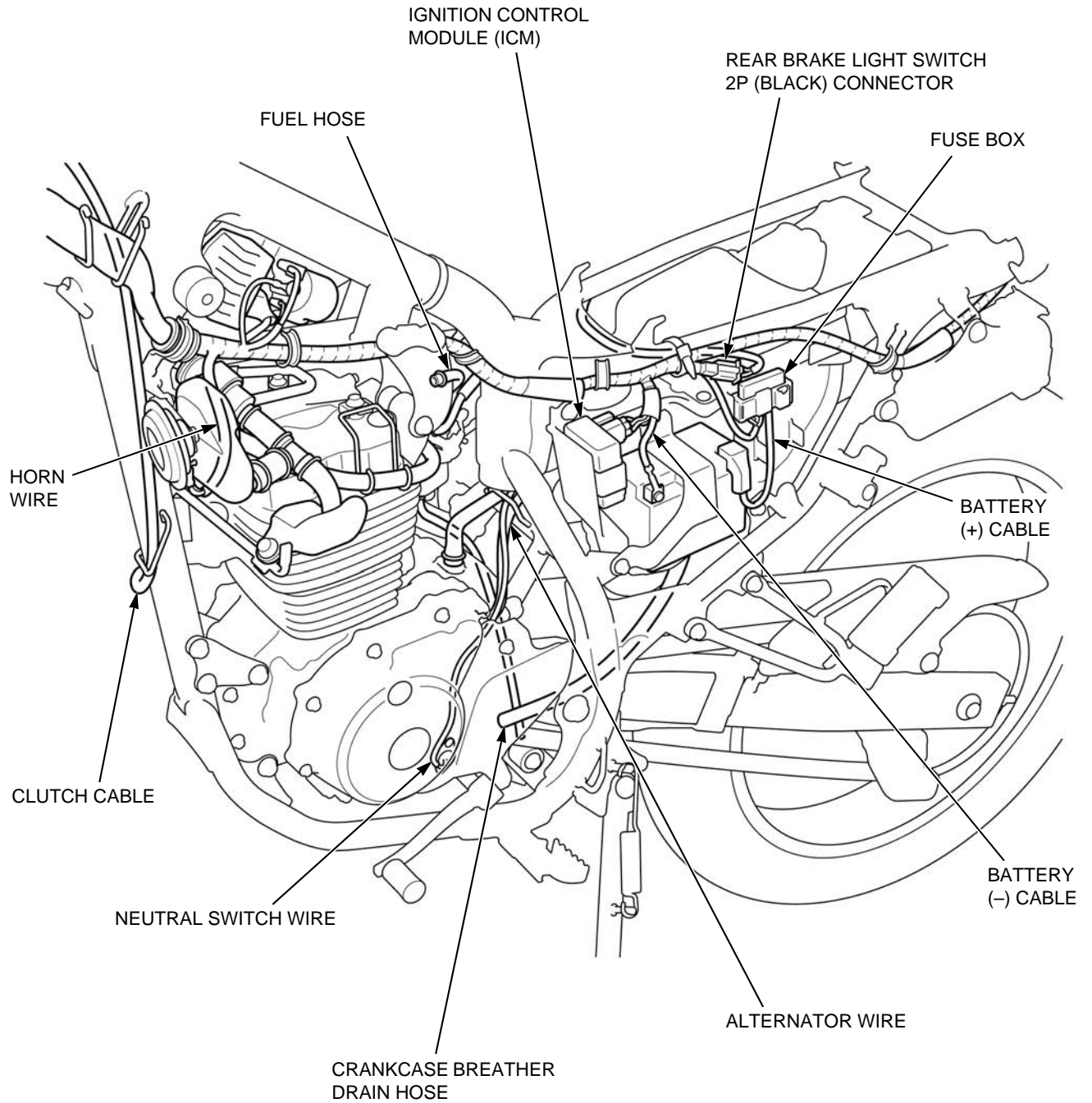

GENERAL INFORMATION

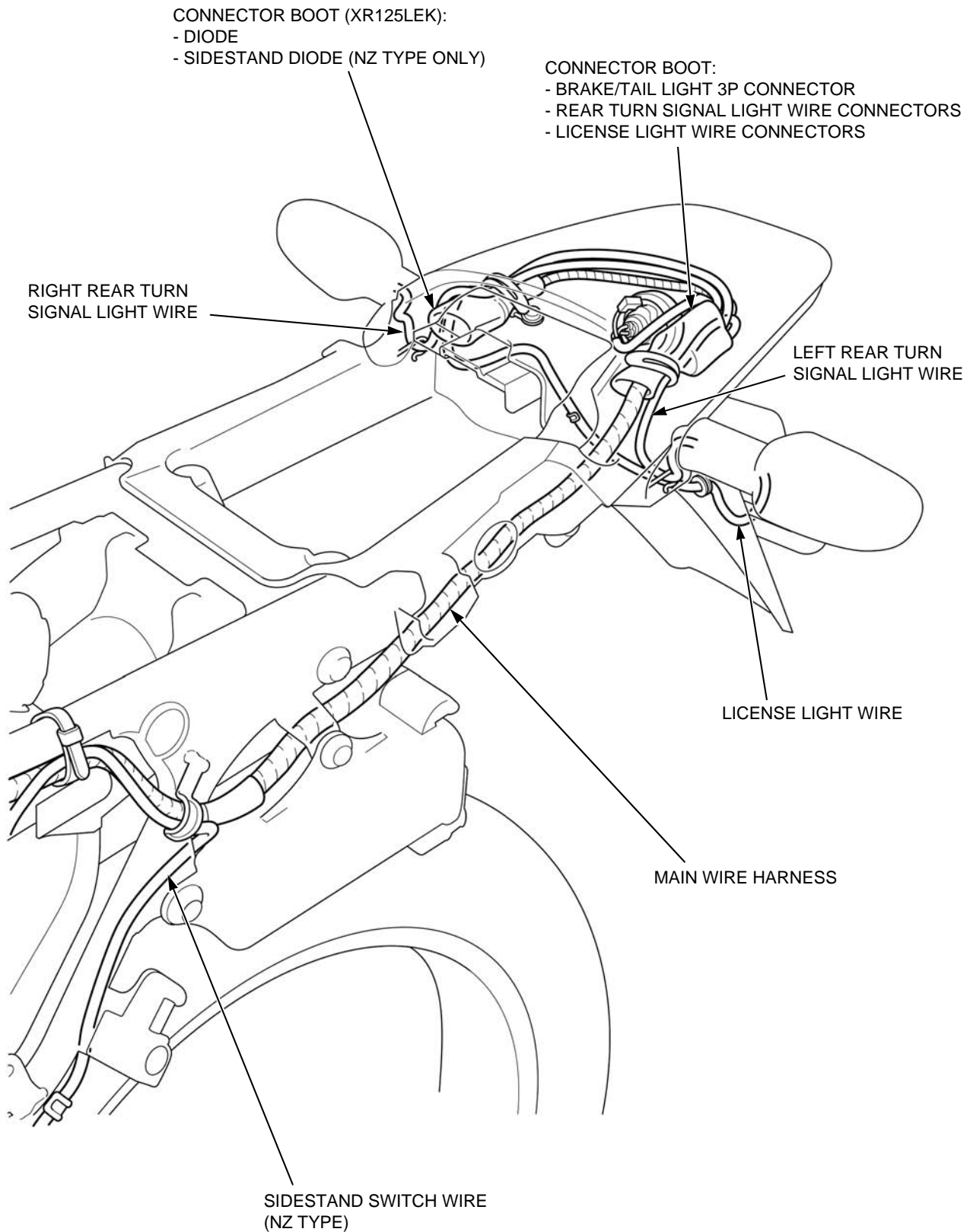

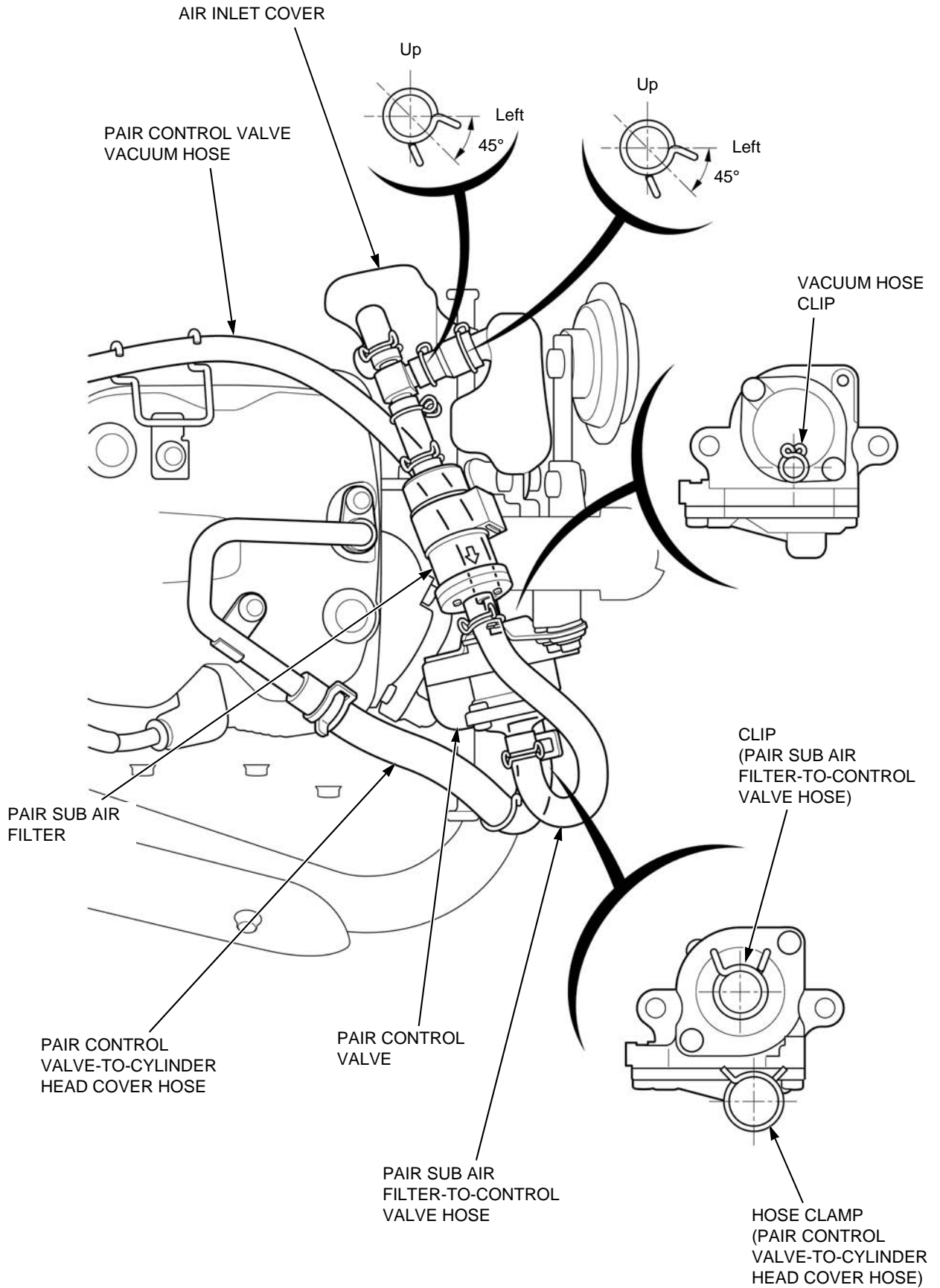

GENERAL INFORMATION

CABLE & HARNESS ROUTING (XL125LK)

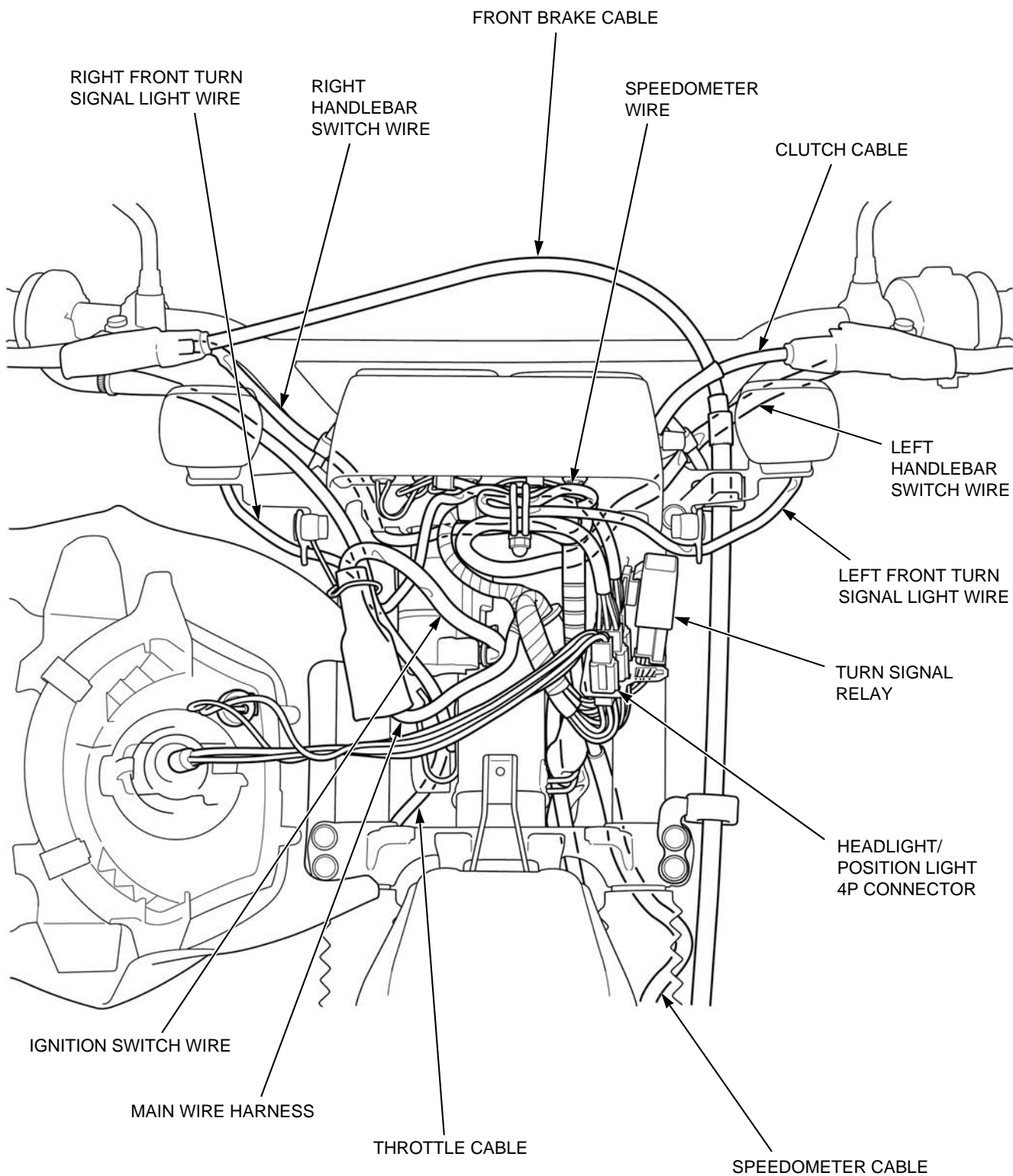

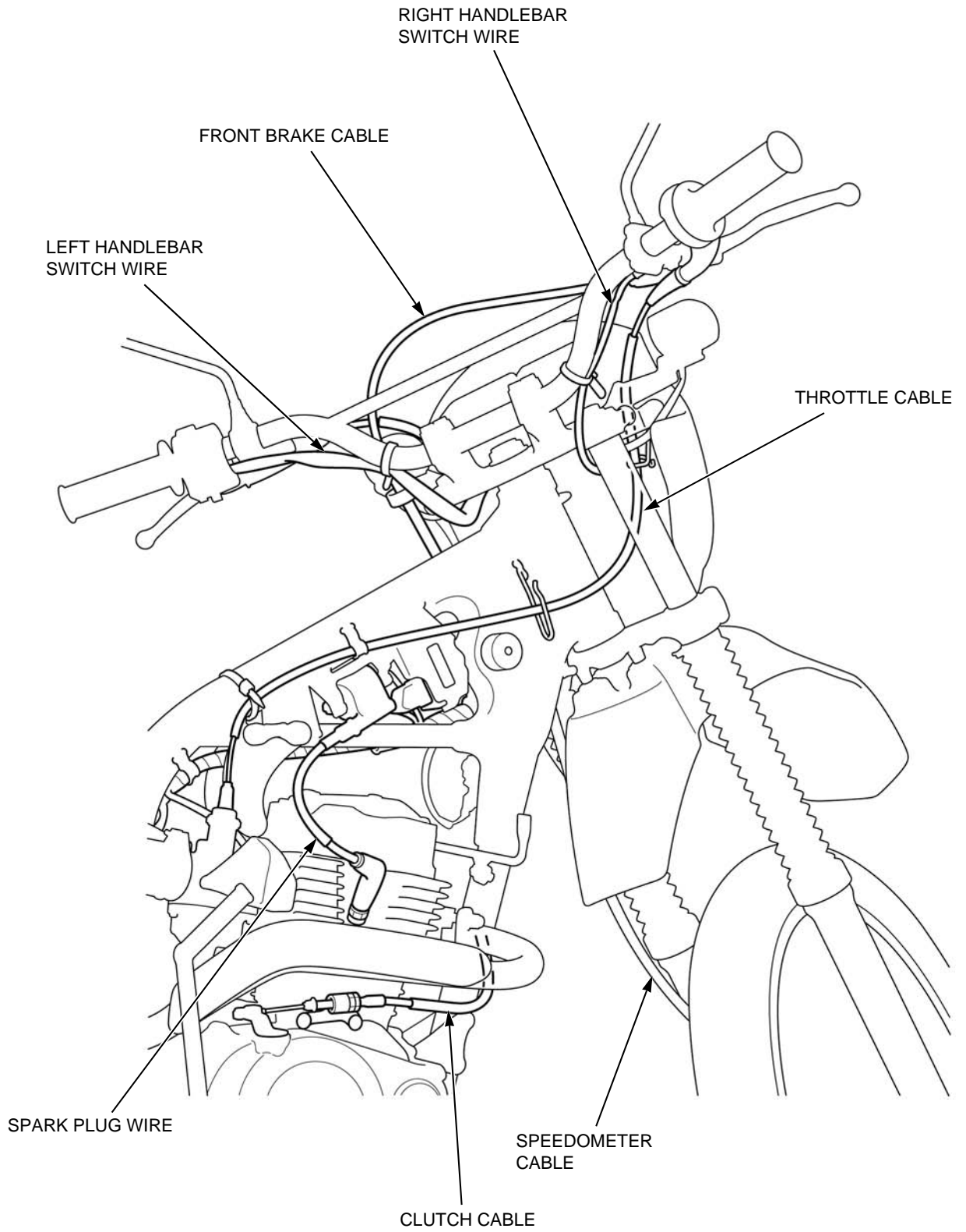

GENERAL INFORMATION

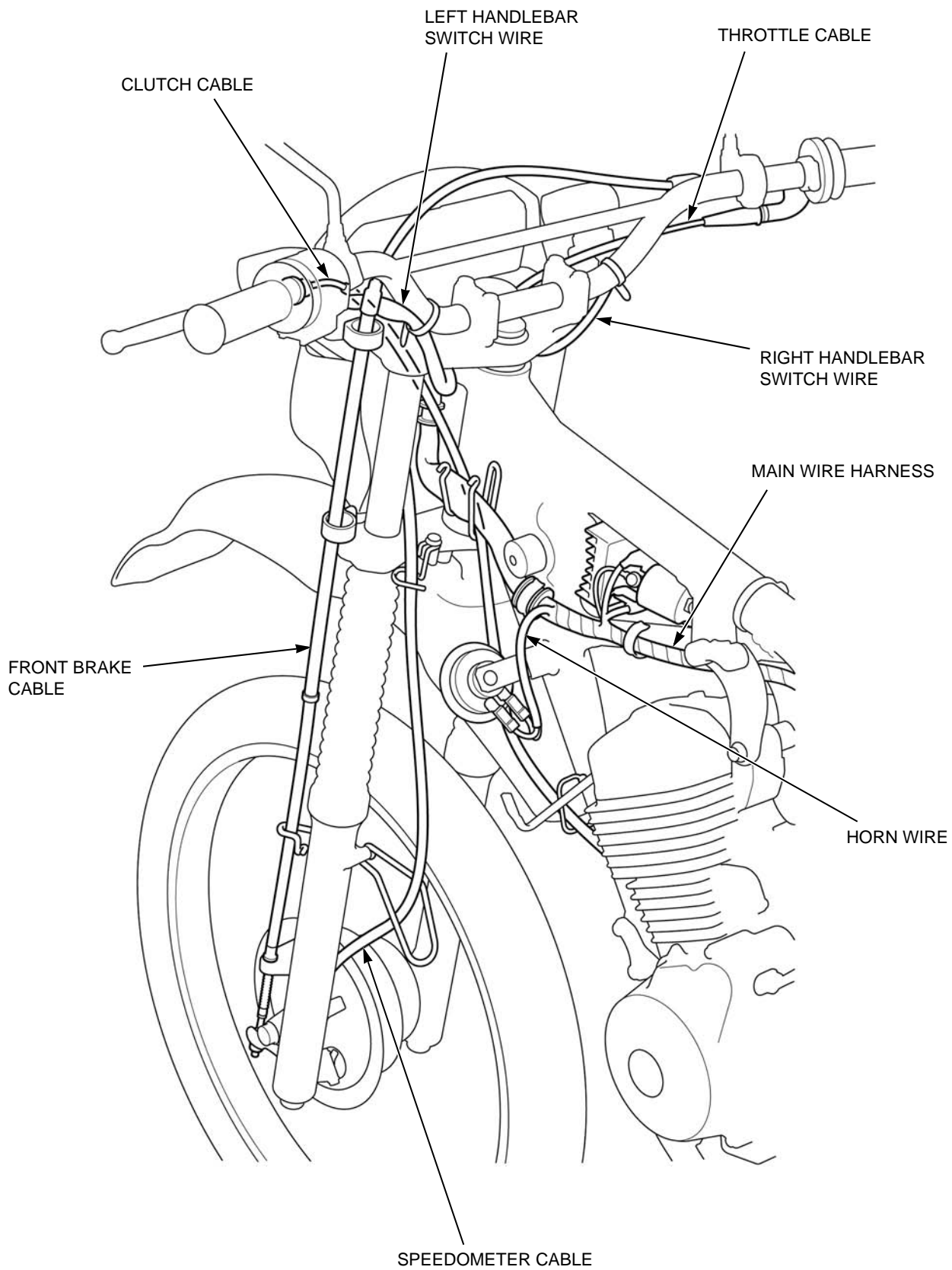

CONNECTOR BOOT:

- NEUTRAL SWITCH WIRE CONNECTOR
- ALTERNATOR 2P CONNECTOR
- IGNITION PULSE GENERATOR WIRE CONNECTOR
- THERMO SWITCH 2P CONNECTOR

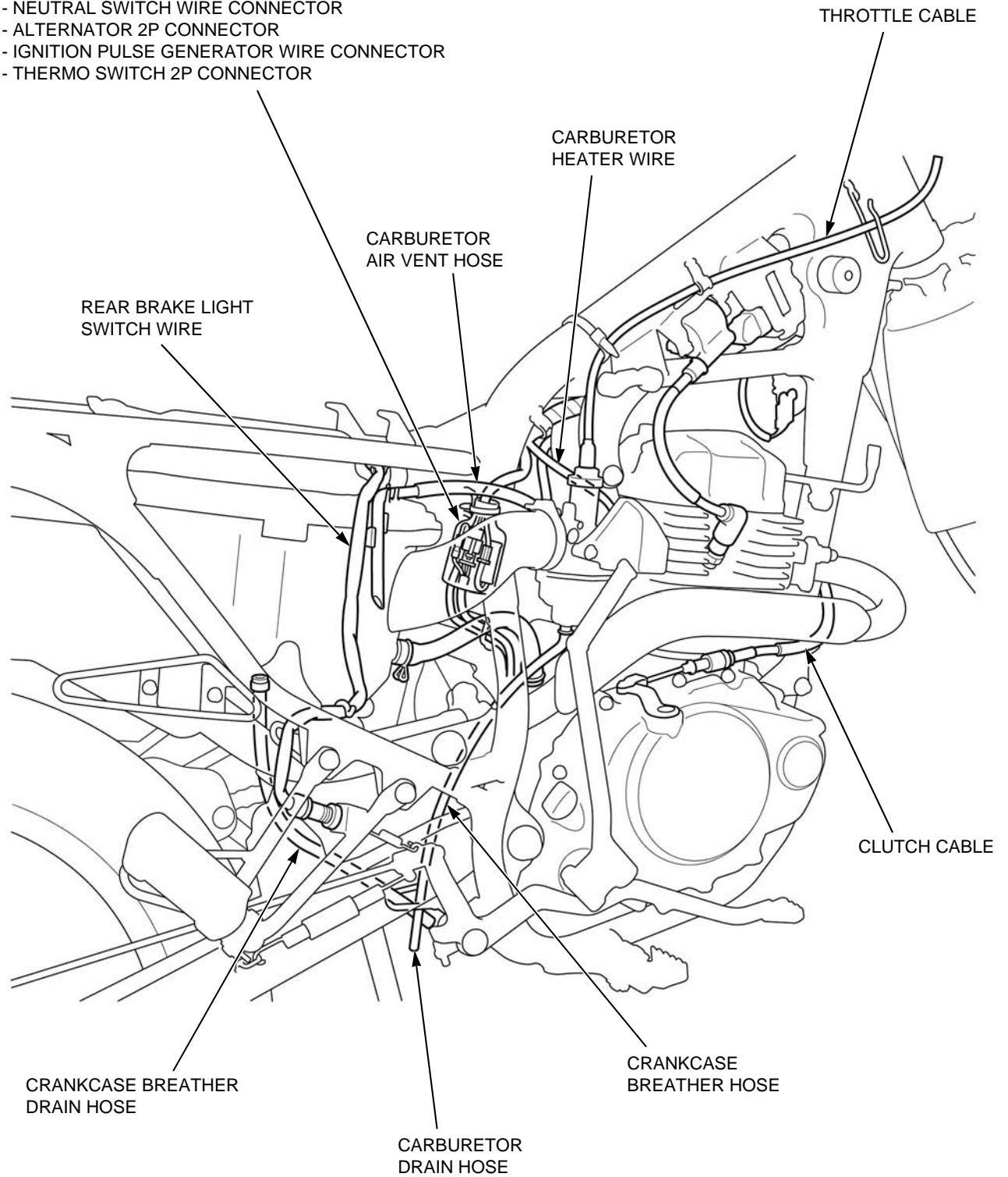

GENERAL INFORMATION

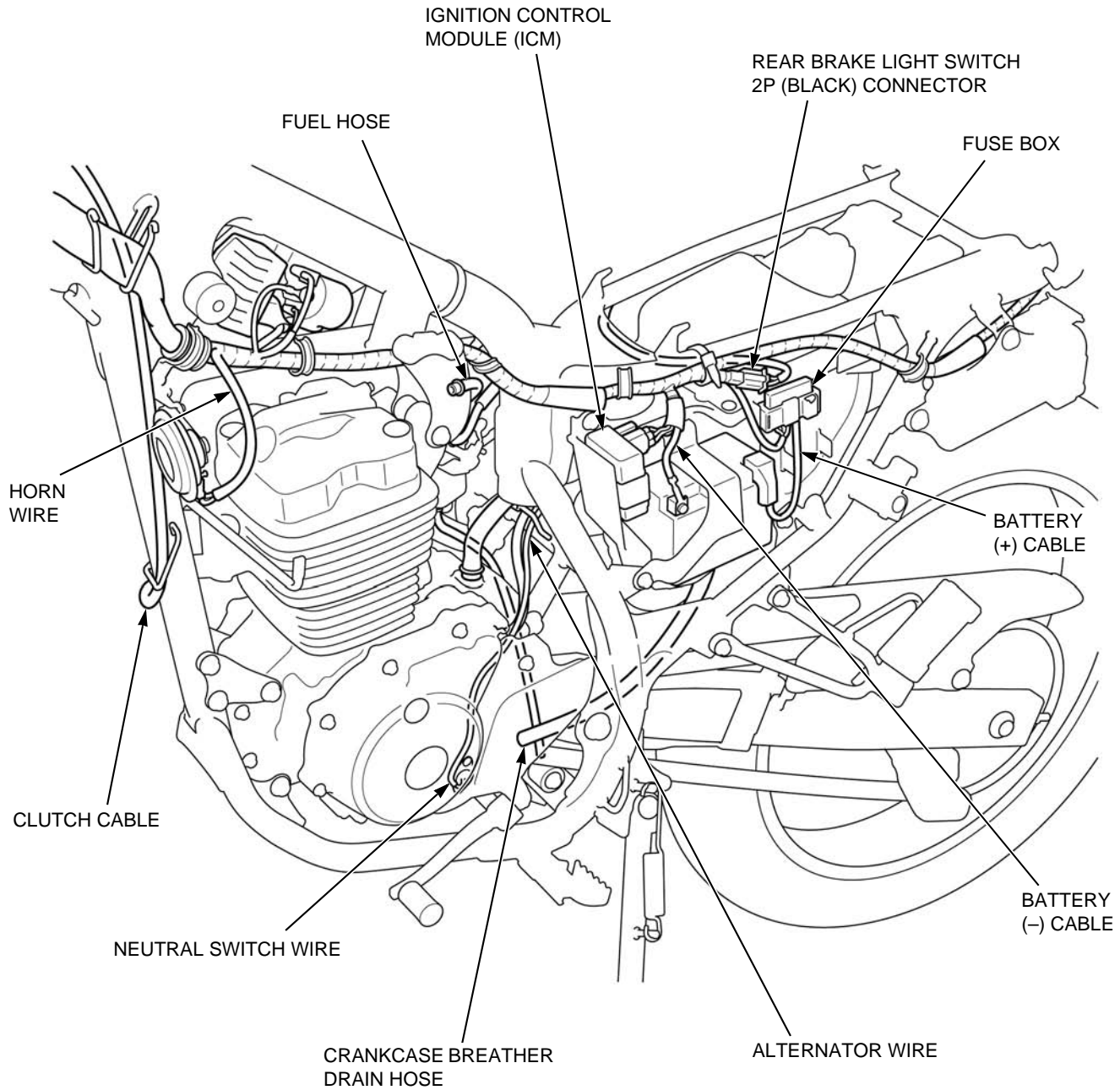

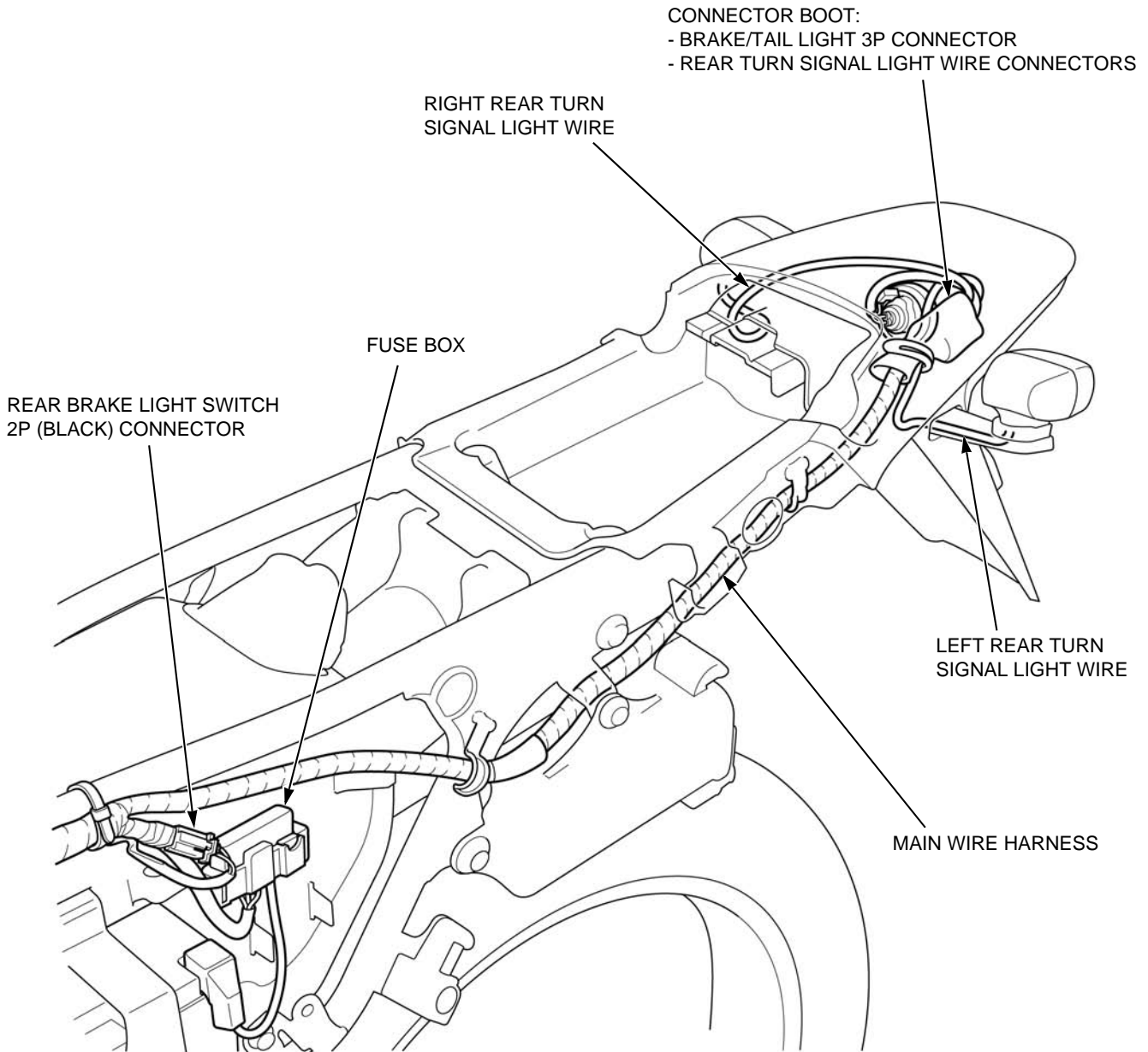

GENERAL INFORMATION

EMISSION CONTROL SYSTEMS

SOURCE OF EMISSIONS

The combustion process produces carbon monoxide, oxides of nitrogen and hydrocarbons. Control of hydrocarbons and oxides nitrogen is very important because, under certain conditions, they react to form photochemical smog when subjected to sunlight. Carbon monoxide does not react in the same way, but it is toxic.

Honda Motor Co., Ltd. utilizes lean carburetor settings as well as other systems, to reduce carbon monoxide, oxides of nitrogen and hydrocarbons.

CRANKCASE EMISSION CONTROL SYSTEM

The engine is equipped with a closed crankcase system to prevent discharging crankcase emissions into the atmosphere. Blow-by gas is returned to the combustion chamber through the air cleaner and carburetor.

EXHAUST EMISSION CONTROL SYSTEM

The exhaust emission control system is composed of a pulse secondary air injection system and lean carburetor settings, no adjustment should be made except idle speed adjustment with the throttle stop screw.

PULSE SECONDARY AIR INJECTION SYSTEM (XR125LK/LEK)

The pulse secondary air injection (PAIR) system introduces filtered air into the exhaust gases in the exhaust port. Fresh air is drawn into the exhaust port by the function of the PAIR (Pulse Secondary Air Injection) control valve.

The reed valve prevents reverse air flow through the system. The PAIR control valve reacts to high intake manifold vacuum and will cut off the supply of fresh air during engine deceleration, thereby preventing afterburn in the exhaust system.

No adjustments to the secondary air supply system should be made, although periodic inspection of the components is recommended.

2. FRAME/BODY PANELS/EXHAUST SYSTEM

SEAT.....	2-2	FUEL TANK	2-4
SIDE COVER	2-2	FRONT VISOR	2-4
REAR CARRIER.....	2-2	FRONT FENDER.....	2-5
REAR COWL	2-3	DRIVE SPROCKET COVER	2-5
NUMBER PLATE BRACKET	2-3	EXHAUST PIPE/MUFFLER	2-6
SIDE SHROUD	2-4		

SEAT

REMOVAL/INSTALLATION

Remove the side cover (page 2-2).

Remove the bolts [1] and collars [2] from both sides of the seat [3].

Remove the seat rearward.

Align the hooks of the frame with the holes of the seat and install the seat.

Install the bolts and collars on both sides, then tighten the bolts.

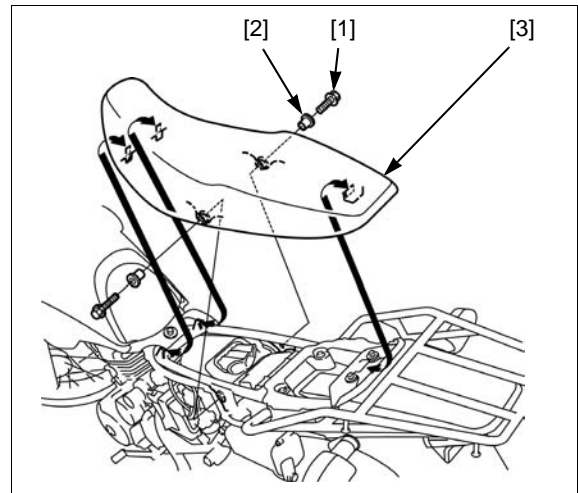

SIDE COVER

REMOVAL/INSTALLATION

Be careful not to damage the bosses on the side covers.

Remove the bolt [1] and collar [2].

Remove the bosses [3] of the side cover [4] from the grommets of the frame, then remove the side cover.

Installation is in the reverse order of removal.

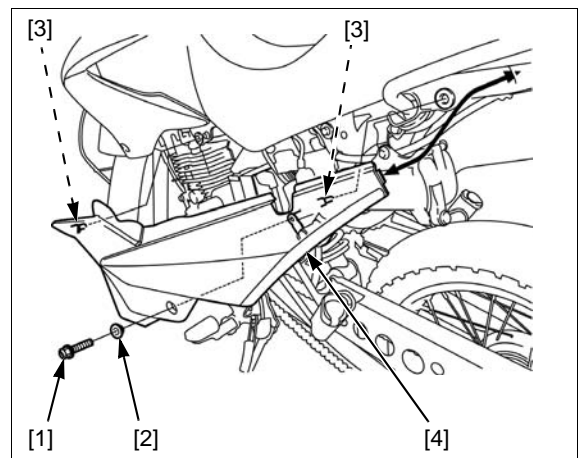

REAR CARRIER

REMOVAL/INSTALLATION

Remove the seat (page 2-2).

Remove the following:

- Bolts [1]
- Collars [2]
- Mount rubbers [3]
- Rear carrier [4]

Installation is in the reverse order of removal.

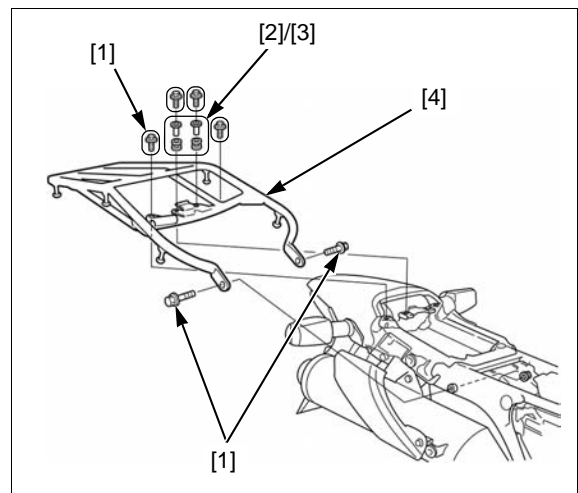

REAR COWL

REMOVAL/INSTALLATION

Remove the following:

- Side covers (page 2-2)
- Seat (page 2-2)
- Rear carrier (page 2-2)

Remove the bolts [1].

Remove the rear cowl [2] by releasing its rubber [3] from the number plate bracket [4].

Installation is in the reverse order of removal.

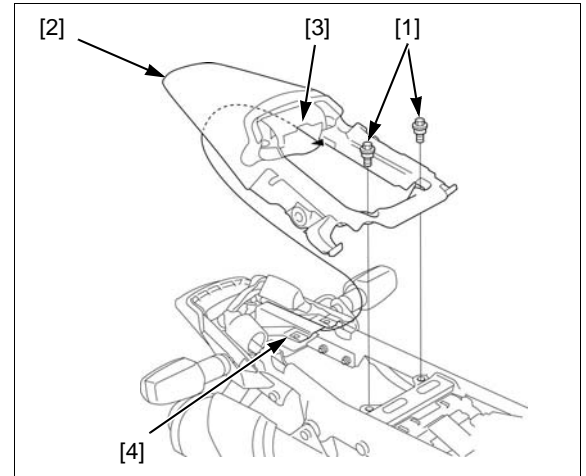

NUMBER PLATE BRACKET

REMOVAL/INSTALLATION

Remove the following:

- Side covers (page 2-2)
- Seat (page 2-2)
- Rear carrier (page 2-2)
- Rear cowl (page 2-3)

Disconnect the brake/tail light 3P connector [1].

Remove the bolts [2], collars [3], clamps [4] and mount rubbers [5].

Remove the number plate bracket [6].

Installation is in the reverse order of removal.

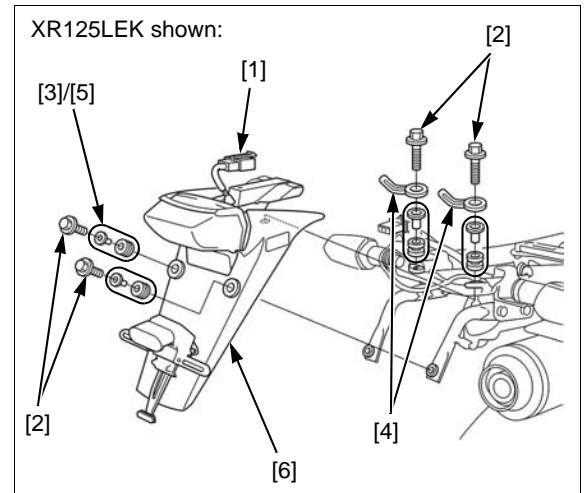

DISASSEMBLY/ASSEMBLY

Remove the license light (page 18-5).

Remove the screws [1], mount rubbers [2], collars [3] and brake/tail light [4].

Assembly is in the reverse order of disassembly.

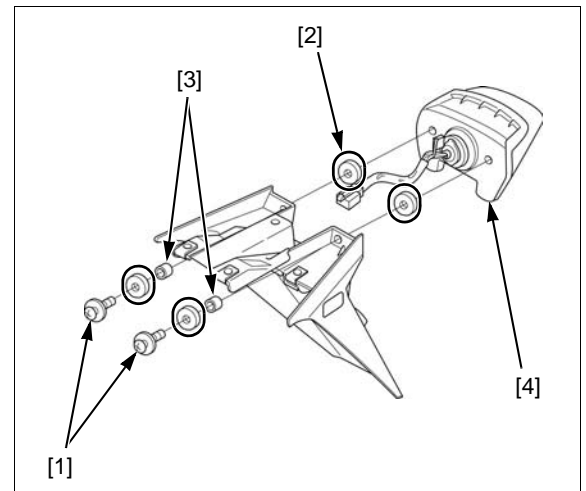

SIDE SHROUD

REMOVAL/INSTALLATION

Remove the side cover (page 2-2).

Remove the screw [1] and bolts [2].

Remove the side shroud [3] while releasing its hole from the hook [4] on the fuel tank.

Installation is in the reverse order of removal.

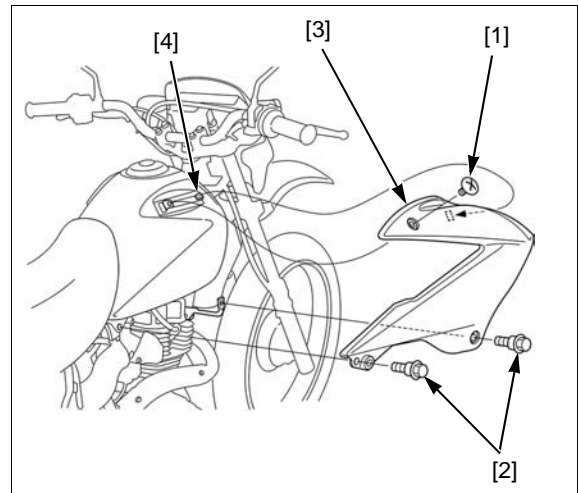

FUEL TANK

REMOVAL/INSTALLATION

Remove the following:

- Side covers (page 2-2)
- Seat (page 2-2)
- Side shrouds (page 2-4)

Turn the fuel valve "OFF".

Disconnect the fuel hose from the fuel valve.

Remove the bolt [1], collar [2] and mount rubber [3].

Remove the fuel tank [4] while releasing it from the rubber mounts [5].

Installation is in the reverse order of removal.

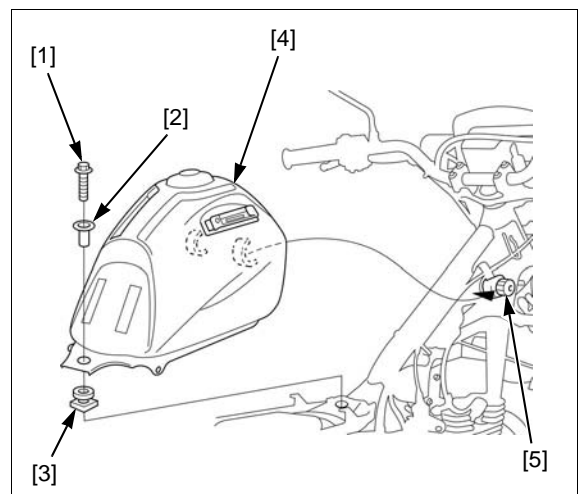

FRONT VISOR

REMOVAL/INSTALLATION

Remove the following:

- Two bolts [1]/setting nuts [2]
- Headlight aim adjusting screw [3]/washer [4]
- Mount rubber [5]
- Collar [6]
- Nut [7]
- Headlight aim adjuster [8]

Disconnect the headlight connector [9] from the front visor [10].

Installation is in the reverse order of removal.

After installation, adjust the headlight aim (page 3-15).

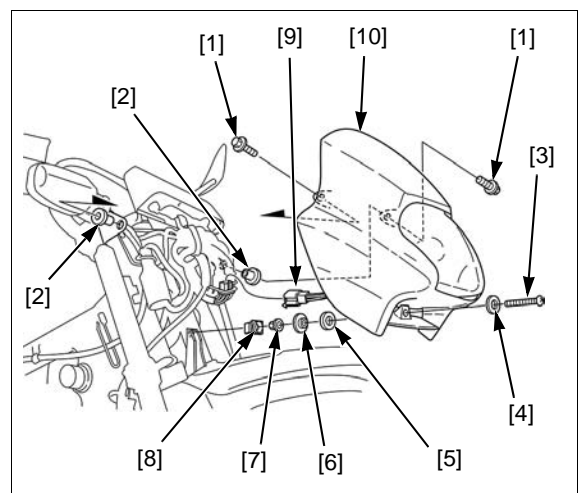

DISASSEMBLY/ASSEMBLY

Remove the screws [1] and plates [2], then separate the visor [3], headlight rubber [4], inner visor [5] and headlight [6].

Assembly is in the reverse order of disassembly.

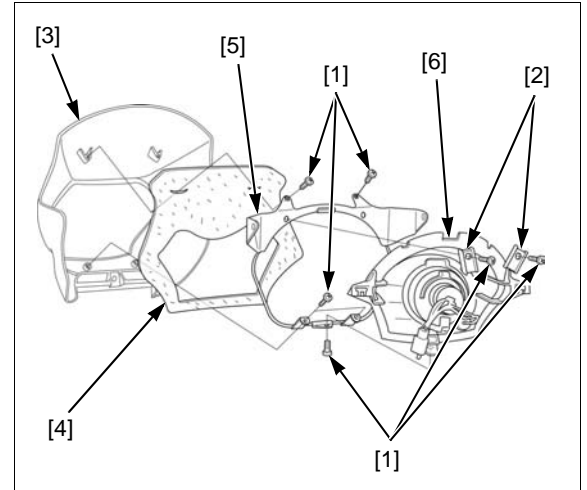

FRONT FENDER

REMOVAL/INSTALLATION

Remove the bolts [1].
Remove the front fender [2], headlight aim adjuster holder [3] and collars [4].

Installation is in the reverse order of removal.

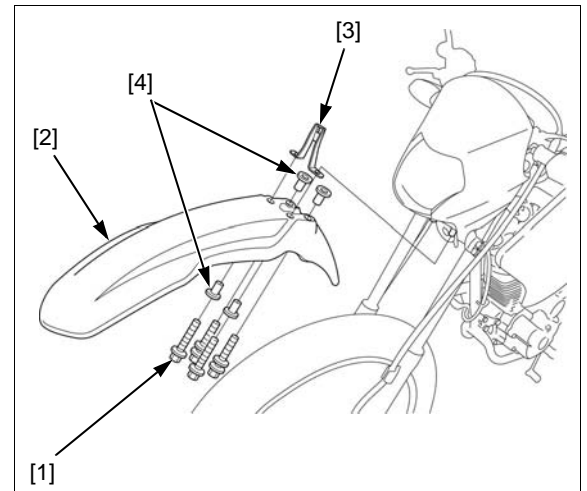

DRIVE SPROCKET COVER

REMOVAL/INSTALLATION

Remove the bolts [1], then remove the drive sprocket cover [2] and drive chain guide [3].

Installation is in the reverse order of removal.

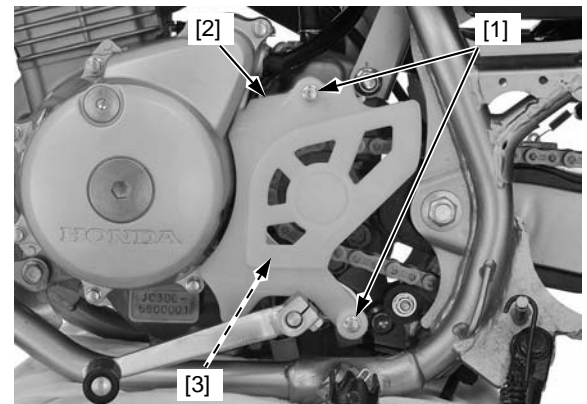

EXHAUST PIPE/MUFFLER

REMOVAL/INSTALLATION

Remove the right side cover (page 2-2).

Loosen the muffler band bolt [1].

Remove the following:

- Front mounting bolt [2] and washer [3]
- Rear mounting bolt [4] and nut [5]
- Muffler [6] and gasket [7]
- Exhaust pipe joint nuts [8]
- Exhaust pipe [9]
- Gasket [10]

- Replace the muffler gasket and exhaust pipe gasket with new ones.
- Temporarily install the exhaust pipe and muffler in the reverse order of removal by loosely installing all the fasteners. Tighten the exhaust pipe joint nuts first, then tighten the muffler band bolt, muffler mounting bolt and nut. After installation, inspect the exhaust system for leaks.

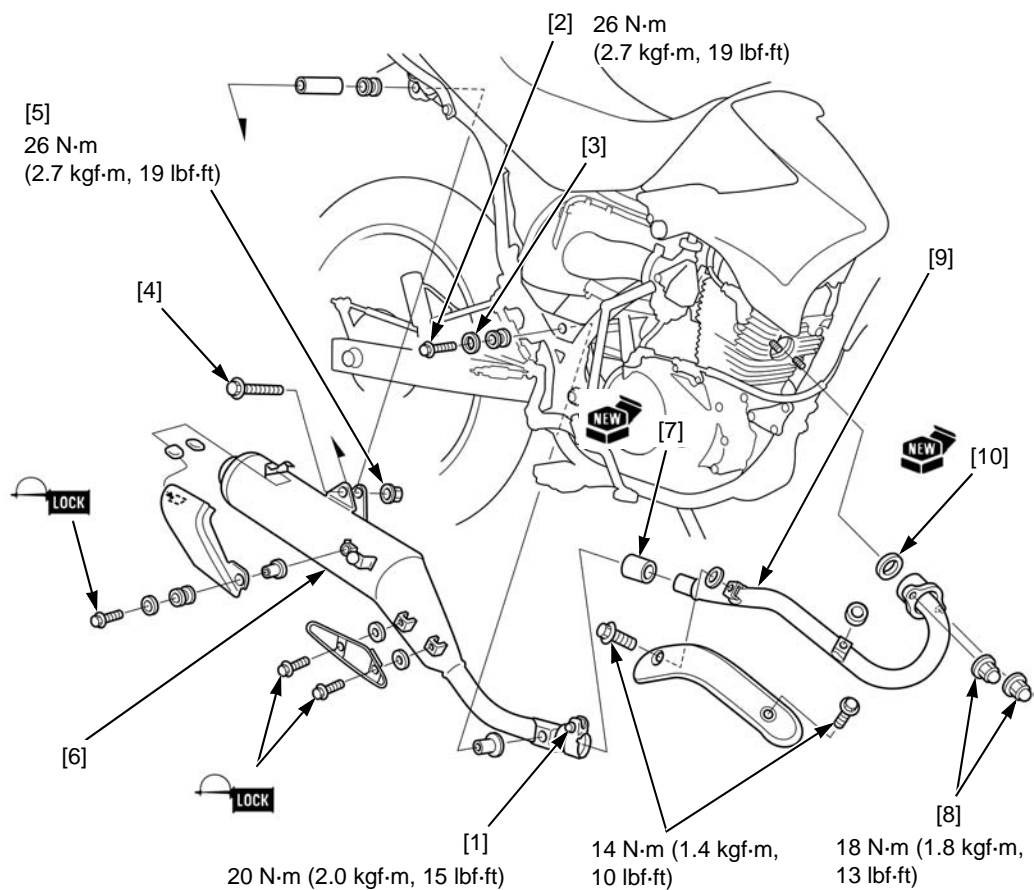

When replacing the stud bolt [1], check that the stud length is within specification as shown.

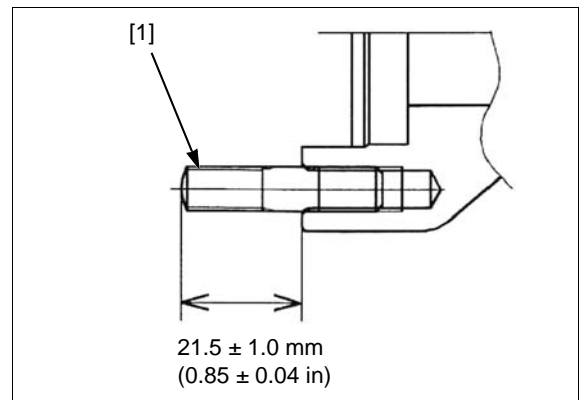

MAINTENANCE SCHEDULE.....	3-2	DRIVE CHAIN	3-9
FUEL STRAINER SCREEN	3-3	DRIVE CHAIN SLIDER	3-11
THROTTLE OPERATION.....	3-3	BRAKE FLUID (XR125LK/LEK).....	3-12
AIR CLEANER.....	3-4	BRAKE SHOES/PADS WEAR	3-12
AIR CLEANER SUB FILTER (XR125LK/LEK)-- 3-4		BRAKE SYSTEM	3-13
CRANKCASE BREATHER	3-5	BRAKE LIGHT SWITCH	3-14
SPARK PLUG.....	3-5	HEADLIGHT AIM	3-15
VALVE CLEARANCE.....	3-6	CLUTCH SYSTEM	3-15
ENGINE OIL	3-7	SIDESTAND.....	3-16
ENGINE OIL STRAINER SCREEN.....	3-7	SUSPENSION	3-16
ENGINE OIL CENTRIFUGAL FILTER	3-8	NUTS, BOLTS, FASTENERS	3-16
ENGINE IDLE SPEED.....	3-8	WHEELS/TIRES.....	3-16
SECONDARY AIR SUPPLY SYSTEM (XR125LK/LEK).....	3-9	STEERING HEAD BEARINGS	3-17

MAINTENANCE

MAINTENANCE SCHEDULE

Perform the Pre-ride inspection in the Owner's Manual at each scheduled maintenance period.

I: Inspect and Clean, Adjust, Lubricate or Replace if necessary. C: Clean. R: Replace. A: Adjust. L: Lubricate.

The following items require some mechanical knowledge. Certain items (particularly those marked * and **) may require more technical information and tools. Consult a dealer.

ITEMS	FREQUENCY	NOTE	ODOMETER READING (NOTE 1)					REFER TO PAGE
			x 1,000 km	1	4	8	12	
			x 1,000 mi	0.6	2.5	5	7.5	
* FUEL LINE				I	I	I	–	
* FUEL STRAINER SCREEN				C	C	C	3-3	
* THROTTLE OPERATION				I	I	I	3-3	
* AIR CLEANER (DK TYPE AND XL125LK)	NOTE 2		EVERY 12,000 km (7,500 mi): R				3-4	
* AIR CLEANER (EXCEPT DK TYPE AND XL125LK)	NOTE 2		EVERY 16,000 km (10,000 mi): R				3-4	
* AIR CLEANER SUB FILTER	NOTE 2			C	C	R	3-4	
CRANKCASE BREATHER	NOTE 3			C	C	C	3-5	
SPARK PLUG				I	R	I	3-5	
* VALVE CLEARANCE			I	I	I	I	3-6	
ENGINE OIL	NOTE 4		R	R	R	R	3-7	
* ENGINE OIL STRAINER SCREEN						C	3-7	
** ENGINE OIL CENTRIFUGAL FILTER						C	3-8	
* ENGINE IDLE SPEED			I	I	I	I	3-8	
* SECONDARY AIR SUPPLY SYSTEM (XR125LK/LEK)	NOTE 6					I	3-9	
DRIVE CHAIN	NOTE 4		EVERY 1,000 km (600 mi): I, L				3-9	
DRIVE CHAIN SLIDER				I	I	I	3-11	
BRAKE FLUID (XR125LK/LEK)	NOTE 5			I	I	I	3-12	
BRAKE SHOES WEAR (XL125LK)				I	I	I	3-12	
BRAKE SHOES/PADS WEAR (XR125LK/LEK)				I	I	I	3-12	
BRAKE SYSTEM			I	I	I	I	3-13	
BRAKE LIGHT SWITCH				I	I	I	3-14	
HEADLIGHT AIM				I	I	I	3-15	
CLUTCH SYSTEM			I	I	I	I	3-15	
SIDESTAND				I	I	I	3-16	
SUSPENSION				I	I	I	3-16	
* NUTS, BOLTS, FASTENERS	NOTE 4		I		I		3-16	
** WHEELS/TIRES	NOTE 4		I	I	I	I	3-16	
** STEERING HEAD BEARINGS			I			I	3-17	

* Should be serviced by a dealer, unless the owner has proper tools and service data and is mechanically qualified.

** In the interest of safety, we recommend these items be serviced only by a dealer.

Honda recommends that a dealer should road test your motorcycle after each periodic maintenance is carried out.

NOTES:

1. At higher odometer reading, repeat at the frequency interval established here.
2. Service more frequently when riding in unusually wet or dusty areas.
3. Service more frequently when riding in rain or at full throttle.
4. Service more frequently when riding OFF-ROAD.
5. Replacement requires mechanical skill.
6. Replace the PAIR air filter every 3 years or 24,000 km (15,000 mi). Replacement requires mechanical skill.

FUEL STRAINER SCREEN

Turn the fuel valve [1] "OFF".
Remove the fuel strainer cup [2] and drain the contents of the cup into a suitable container.

Remove the O-ring [3] and fuel strainer screen [4].
Wash the fuel strainer screen and cup in clean non-flammable high flash point solvent.

Check the O-ring and replace with a new one if necessary.

Install the fuel strainer screen, O-ring and fuel strainer cup in the fuel valve body, make sure that the O-ring is in place.

Tighten the fuel strainer cup securely.

Turn the fuel valve "ON" and be sure there are no fuel leaks.

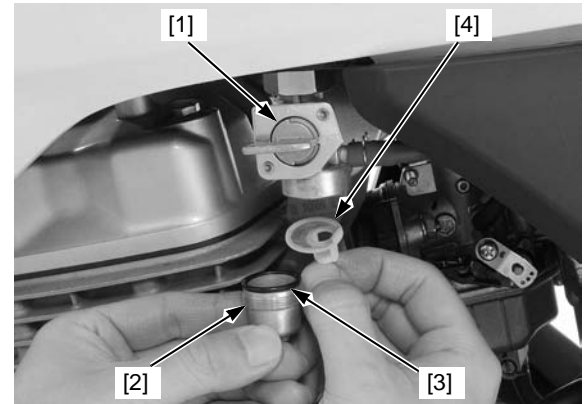

THROTTLE OPERATION

Check for any deterioration or damage to the throttle cable. Check the throttle grip for smooth operation. Check that the throttle opens and automatically closes in all steering positions.

If the throttle grip does not return properly, lubricate the throttle cable and throttle housing.

For cable lubrication: Disconnect the throttle cable at its upper end. Thoroughly lubricate the cable and its pivot points with a commercially available cable lubricant or a light weight oil.

If the throttle grip still does not return properly, replace the throttle cables.

With the engine idling, turn the handlebar all the way to the right and left to ensure that the idle speed does not change. If idle speed increase, check the throttle grip free play and the throttle cable connection.

Measure the free play at the throttle grip flange.

FREE PLAY: 2.0 – 6.0 mm (0.08 – 0.24 in)

Slide the dust cover [1].

Turn the adjuster [2] as required.

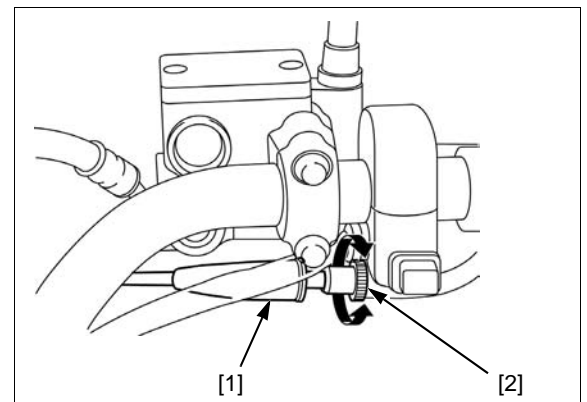
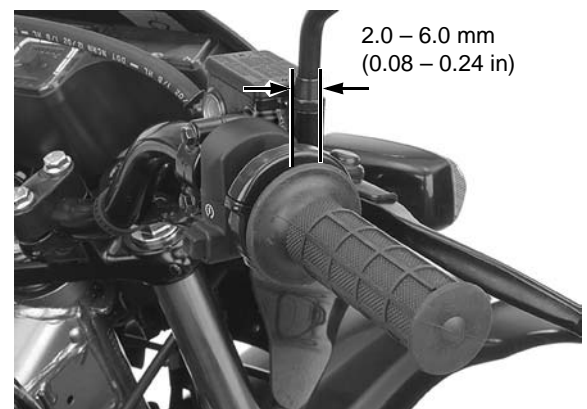

MAINTENANCE

AIR CLEANER

- The viscous paper element cannot be cleaned because the element contains a dust adhesive.
- If the motorcycle is used in unusually wet or dusty areas, more frequent inspections are required.

Remove the following:

- Side covers (page 2-2)
- Seat (page 2-2)

Remove the screws [1] and air cleaner case cover [2].

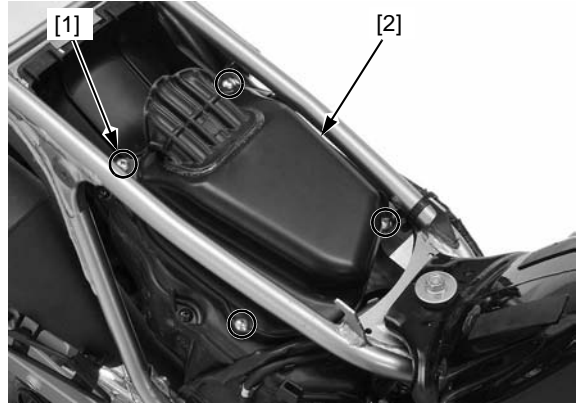

Remove the air cleaner element screws [1].

Replace the element [2] in accordance with the maintenance schedule or anytime it is excessively dirty or damaged.

Check that the packings in good condition, replace them if necessary.

Install the removed parts in the reverse order of removal.

TORQUE:

- Air cleaner element screw:**
1.1 N·m (0.1 kgf·m, 0.8 lbf·ft)
- Air cleaner case cover screw:**
1.1 N·m (0.1 kgf·m, 0.8 lbf·ft)

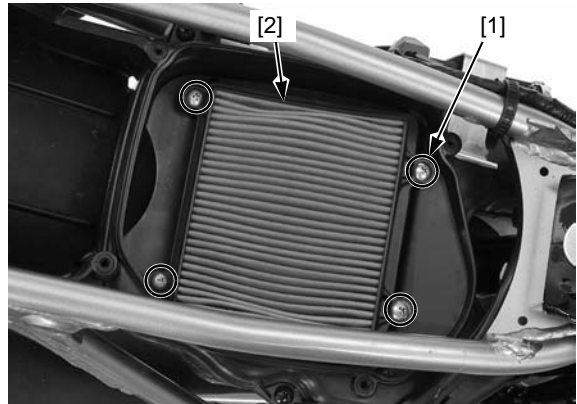

AIR CLEANER SUB FILTER (XR125LK/LEK)

Remove the following:

- Side shroud (page 2-4)
- Fuel tank (page 2-4)

Check the air cleaner sub filter [1] and replace if necessary.

When replacing the sub filter, remove the following.

Disconnect the air cleaner sub filter-to-PAIR control valve hose [2].

Disconnect the air cleaner sub filter-to-three way joint hose [3] and remove the air cleaner sub filter.

Installation is in the reverse order of removal.

Install the air filter, turning its arrow mark [4] in the direction as shown in the illustration.

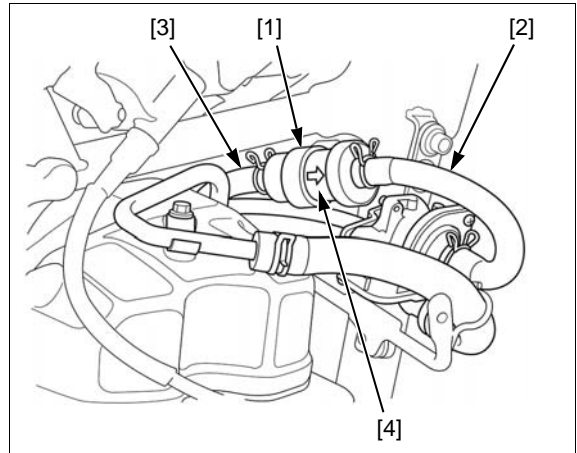

CRANKCASE BREATHER

- Service more frequently when ridden in rain, at full throttle, or after the motorcycle is washed or overturned. Service if the deposits level can be seen in the transparent section of the breather drain hose.

Remove the drain plug [1] from the breather drain hose [2] and drain deposits into a suitable container.

Reinstall the drain plug.

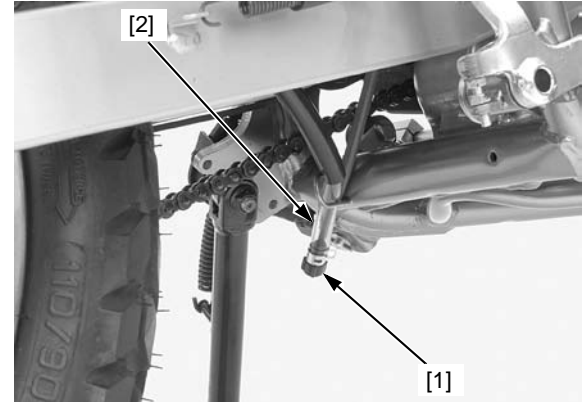

SPARK PLUG

REMOVAL/INSTALLATION

Disconnect the spark plug cap [1], and clean around the spark plug base.

Remove the spark plug [2].

Inspect or replace as described in the maintenance schedule (page 3-2).

RECOMMENDED SPARK PLUGS:

Standard:

CPR7EA-9 (NGK)

For extended high speed riding:

CPR8EA-9 (NGK)

Install and hand tighten the spark plug to the cylinder head, and then tighten the spark plug to the specified torque.

TORQUE: 16 N·m (1.6 kgf·m, 12 lbf·ft)

Connect the spark plug cap.

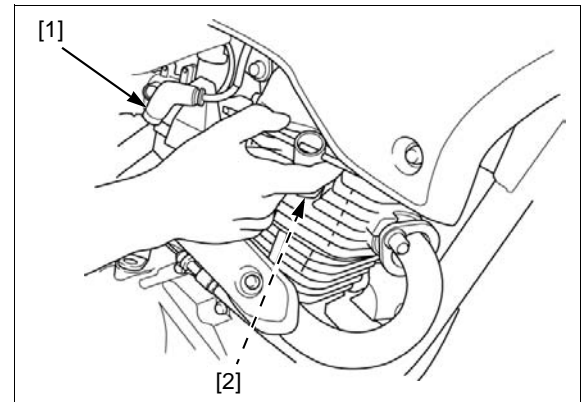

INSPECTION

Check the following and replace if necessary.

- Insulator for damage
- Center electrode and side electrode for wear
- Burning condition, coloration;
 - Dark to light brown indicates good condition
 - Excessive lightness indicates malfunctioning ignition system or lean mixture
 - Wet or black sooty deposit indicates over-rich mixture

Clean the spark plug electrodes with a wire brush or special plug cleaner.

Check the gap between the center and side electrodes with feeler gauge.

SPARK PLUG GAP:

0.80 – 0.90 mm (0.031 – 0.035 in)

If necessary, adjust the gap by bending the side electrode carefully.

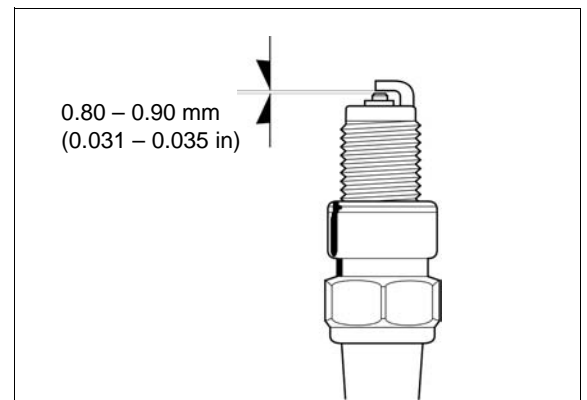

MAINTENANCE

VALVE CLEARANCE

INSPECTION

Inspect and adjust the valve clearance while the engine is cold (below 35°C/95°F).

Remove the cylinder head cover (page 8-4).
Remove the timing and crankshaft hole caps.
Rotate the crankshaft counterclockwise and align the "T" mark [1] on the flywheel with the index notch [2] in the crankcase cover.

Make sure the piston is at TDC (Top Dead Center) on the compression stroke.
This position can be obtained by confirming that there is slack in each rocker arm. If there is no slack, it is because the piston is moving through the exhaust stroke to TDC. Rotate the crankshaft one full turn and match up the "T" mark again.

When checking the clearance, slide the feeler gauge from the center toward the outside.

Check the clearances of the intake and exhaust valves by inserting the feeler gauge [1] between the adjusting screw and valve stem.

VALVE CLEARANCE:

IN: 0.08 ± 0.02 mm (0.003 ± 0.001 in)
EX: 0.12 ± 0.02 mm (0.005 ± 0.001 in)

Adjust by loosening the lock nut [1] and turning the adjusting screw [2] until there is a slight drag on the feeler gauge.

TOOL:

[3] Valve adjusting wrench 07708-0030400

Apply engine oil to the lock nut.
Hold the adjusting screw and tighten the lock nut.

TORQUE: 14 N·m (1.4 kgf·m, 10 lbf·ft)

After tightening the lock nut, recheck the valve clearance.

Coat new O-rings [1] with engine oil and install them onto the crankshaft hole cap [2] and timing hole cap [3].
Apply grease to crankshaft hole cap threads.

Install the caps and tighten them to the specified torque.

TORQUE:

Crankshaft hole cap: 15 N·m (1.5 kgf·m, 11 lbf·ft)
Timing hole cap: 10 N·m (1.0 kgf·m, 7 lbf·ft)

Install the cylinder head cover (page 8-4).

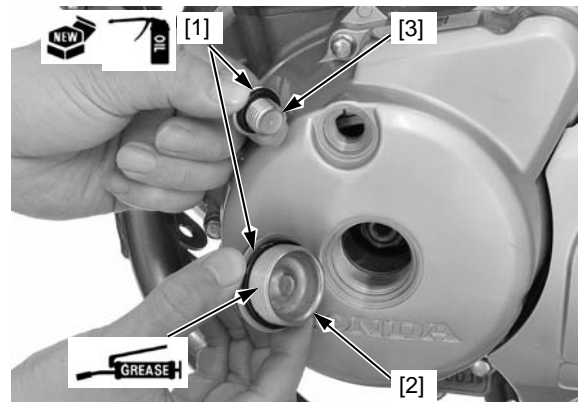
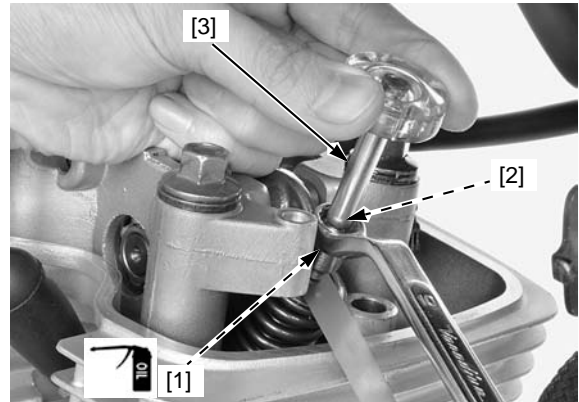
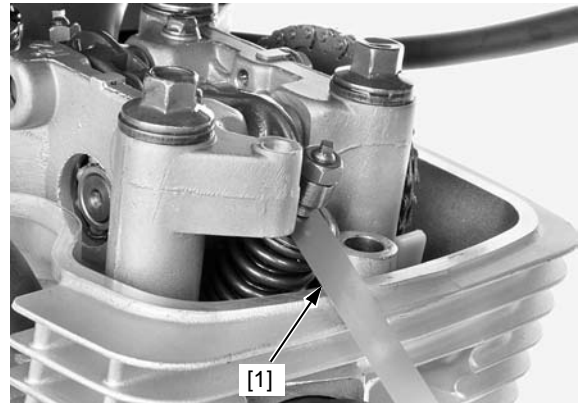
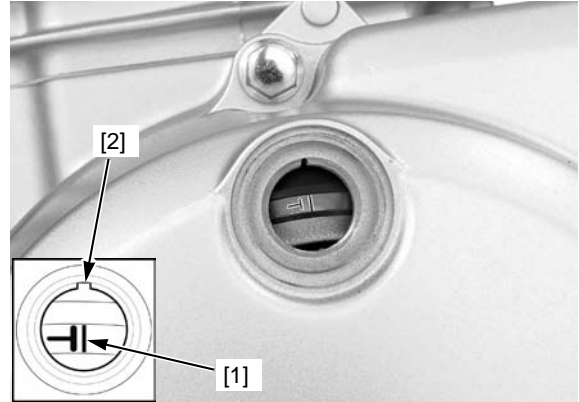

ENGINE OIL

OIL LEVEL INSPECTION

Clean around the oil filler cap/dipstick and nearby surface.

Start the engine and let it idle for 3 – 5 minutes.
Stop the engine and wait 2 – 3 minutes.

Hold the motorcycle in an upright position.

Remove the oil filler cap/dipstick [1] and wipe it clean.
Reinstall the oil filler cap/dipstick, but do not screw it.

Remove the oil filler cap/dipstick and check the oil level.

If the level is below or near the lower mark [2] on the dipstick, fill the crankcase with recommended oil to the upper level [3].

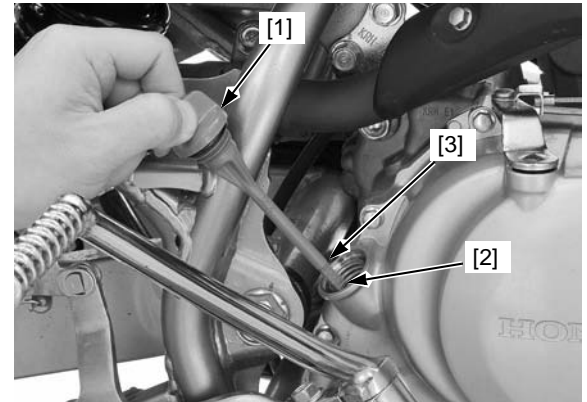

RECOMMENDED ENGINE OIL:

Honda "4-stroke motorcycle oil" or an equivalent
API classification: SG or higher
(except oils labeled as energy conserving on the circular API service label)

Viscosity: SAE 10W-30

JASO T 903 standard: MA

Check that the O-ring is in good condition, replace it if necessary.

Apply engine oil to the O-ring.

Install the oil filler cap/dipstick.

ENGINE OIL CHANGE

Warm up the engine.

Stop the engine and remove the oil filler cap/dipstick.

Remove the drain bolt [1] and sealing washer [2] and drain the engine oil completely.

Install a new sealing washer onto the drain bolt.

Install the drain bolt with a new sealing washer and tighten it to the specified torque.

TORQUE: 30 N·m (3.1 kgf·m, 22 lbf·ft)

Fill the crankcase with the recommended engine oil.

ENGINE OIL CAPACITY:

1.0 liter (1.1 US qt, 0.9 Imp qt) after draining

1.2 liters (1.3 US qt, 1.1 Imp qt) after disassembly

Check the oil level. Make sure there are no oil leaks.

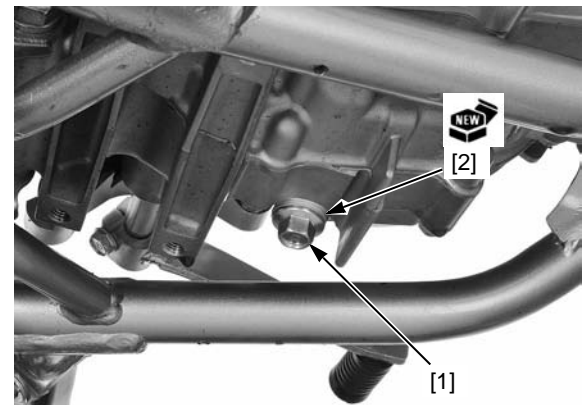

ENGINE OIL STRAINER SCREEN

Remove the right crankcase cover (page 10-4).

Remove the oil strainer screen [1] out of the crankcase.

Wash the strainer screen thoroughly in non-flammable or high flash point solvent until all accumulated dirt has been removed.

Blow dry it with compressed air to clean completely.

Before installing the strainer, the screen mesh should be examined closely for damage.

Install the strainer screen in the direction as shown.

Install the right crankcase cover (page 10-4).

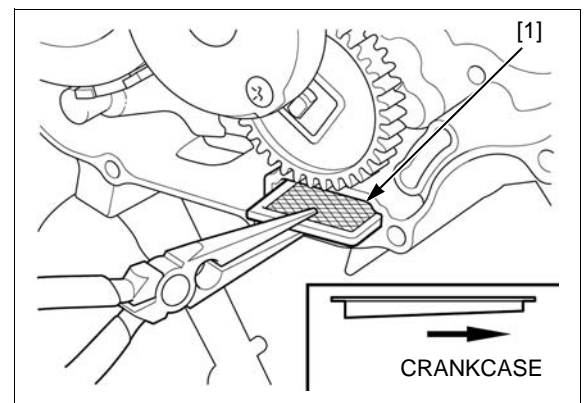

MAINTENANCE

ENGINE OIL CENTRIFUGAL FILTER

Remove the right crankcase cover (page 10-4).

Remove the following:

- Screws [1]
- Oil filter rotor cover [2]
- Gasket [3]

Clean the oil filter rotor cover and inside of the oil filter rotor using a clean lint-free cloth.

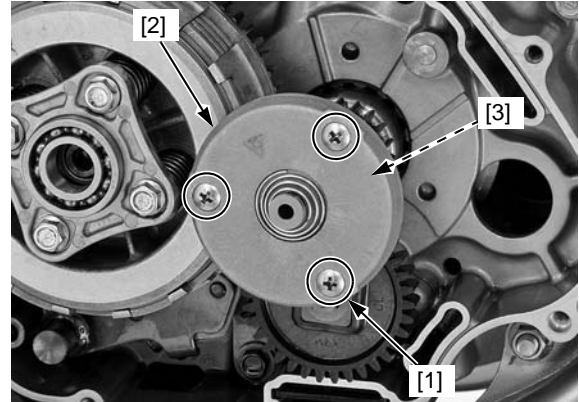

Remove the clip [1] while holding the oil through [2].
Remove the oil through and spring [3].

Blow compressed air through the oil through hole and the rotor cover [4] to clean them.

Apply engine oil to the oil through sliding area.
Install the spring and oil through, and secure it with the clip.

Check that the oil through operates freely, without binding.

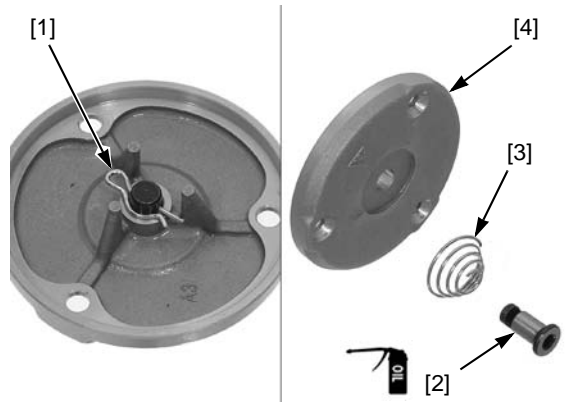

Install the rotor cover [1] with a new gasket [2] and tighten the three screws.

TORQUE: 4.0 N-m (0.4 kgf-m, 3.0 lbf-ft)

Install the right crankcase cover (page 10-4).

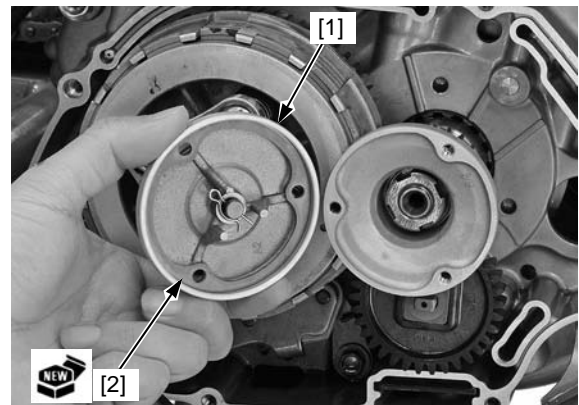

ENGINE IDLE SPEED

- Inspect and adjust the idle speed after all other engine maintenance items have been performed and are within specifications.
- Engine must be warm for accurate adjustment. Ten minutes of stop-and-go riding is sufficient.

Warm the engine, shift the transmission into neutral and support the motorcycle upright on a level surface.

Connect a tachometer and check the idle speed.

IDLE SPEED: 1,500 ± 100 min⁻¹ (rpm)

If the adjustment is necessary, turn the throttle stop screw [1] as required.

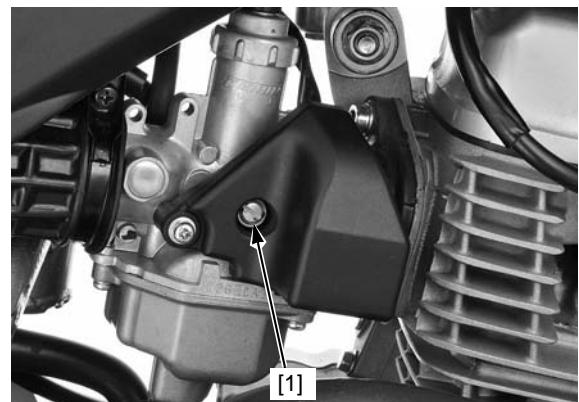

SECONDARY AIR SUPPLY SYSTEM (XR125LK/LEK)

- The secondary air supply system introduces filtered air into exhaust gases in the exhaust port. The secondary air is drawn into the exhaust port whenever there is negative pressure pulse in the exhaust system. This charged secondary air promotes burning of the unburned exhaust gases and changes a considerable amount of hydrocarbons and carbon monoxide into relatively harmless carbon dioxide and water.

If the hoses show any signs of heat damage, inspect the PAIR check valve in the PAIR reed valve cover for damage.

Check the PAIR (pulse secondary air injection) hoses between the air cleaner sub filter [1], PAIR control valve [2] and cylinder head cover for deterioration, damage or loose connections. Make sure that the hoses are not cracked.

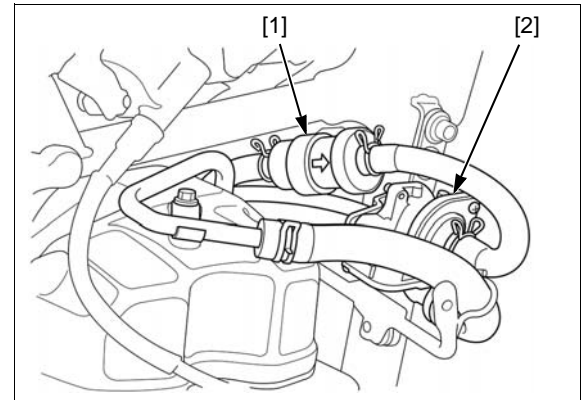

Check the PAIR hoses [1] between the air cleaner sub filter and air inlet cover for deterioration, damage or loose connections. Make sure that the hoses are not kinked, pinched or cracked.

Check the vacuum hose [2] between the PAIR control valve and carburetor insulator for deterioration, damage or loose connections. Make sure that the hoses are not kinked, pinched or cracked.

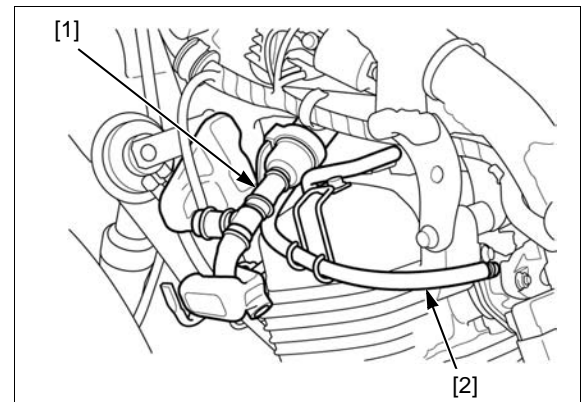

DRIVE CHAIN

DRIVE CHAIN SLACK INSPECTION

Turn off the engine, support the motorcycle on its sidestand and shift the transmission into neutral.

Check the slack in the drive chain lower run midway between the sprockets.

CHAIN SLACK: 20 – 30 mm (0.8 – 1.2 in)

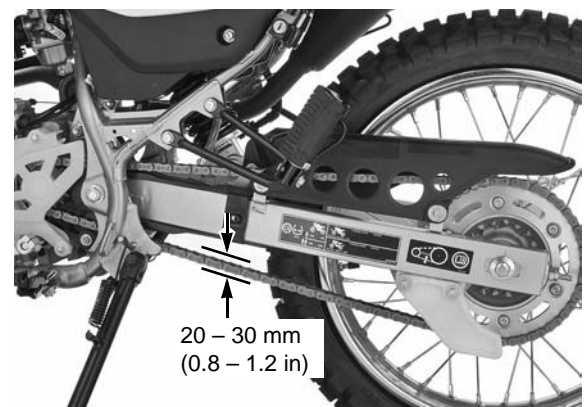

MAINTENANCE

ADJUSTMENT

Loosen the rear axle nut [1].
Loosen the lock nuts [2] and turn the adjusting nuts [3] until the correct drive chain slack is obtained.

Make sure that the index marks on both adjusters are aligned with the rear edges of the axle slots in the swingarm.

Tighten the rear axle nut to the specified torque.

TORQUE: 93 N·m (9.5 kgf·m, 69 lbf·ft)

Hold the adjusting nuts and tighten the lock nuts

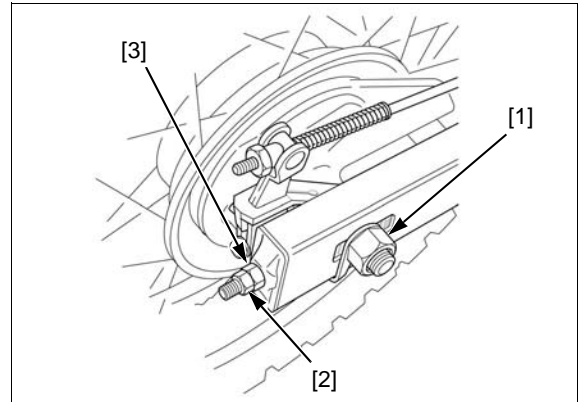

REPLACEMENT

If the red zone [1] on the drive chain wear label [2] aligns with the arrow mark [3] after the drive chain has been adjusted to the proper drive chain slack, the drive chain is excessively worn and must be replaced.

Refer to procedure for swingarm removal/installation (page 15-13).

REPLACEMENT CHAIN: CHOHO428HO-130LE

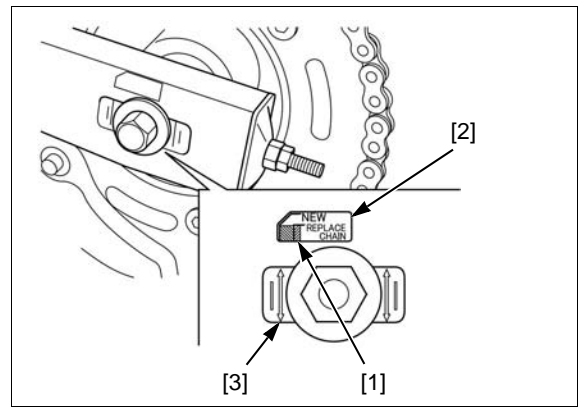

CLEANING AND LUBRICATION

Clean the drive chain [1] with a chain cleaner designed specifically for O-ring chains or a neutral detergent. Use a soft brush if the drive chain is dirty.

NOTICE

Do not use a steam cleaner, high pressure cleaner, wire brush, volatile solvent such as gasoline and benzene, abrasive cleaner or a chain cleaner NOT designed specifically for O-ring chains to clean the drive chain.

Inspect the drive chain for possible damage or wear.

Replace any drive chain that has damaged rollers, loose fitting links, or otherwise appears unserviceable.

Lubricate the drive chain with drive chain lubricant [2] designed specifically for use with O-ring chains, # 80 – 90 gear oil or equivalent.

NOTICE

Do not use a chain lubricant NOT designed specifically for use with O-ring chains to lubricate the drive chain.

Wipe off the excess oil or drive chain lubricant.

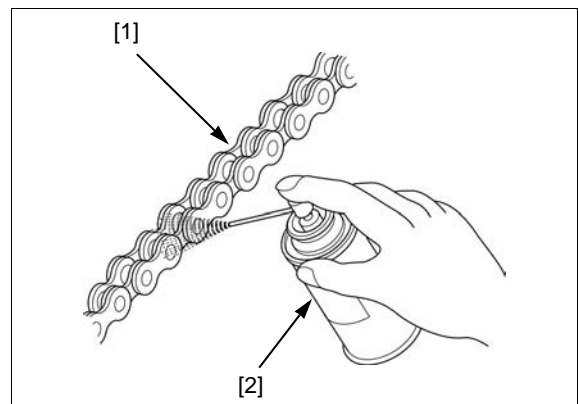

SPROCKET INSPECTION

Remove the drive sprocket cover (page 2-5).

Inspect the drive and driven sprocket teeth for wear [1] or damage [2], replace if necessary.

Never use a new drive chain on worn sprockets.

Both chain and sprockets must be in good condition [3], or new replacement chain will wear rapidly.

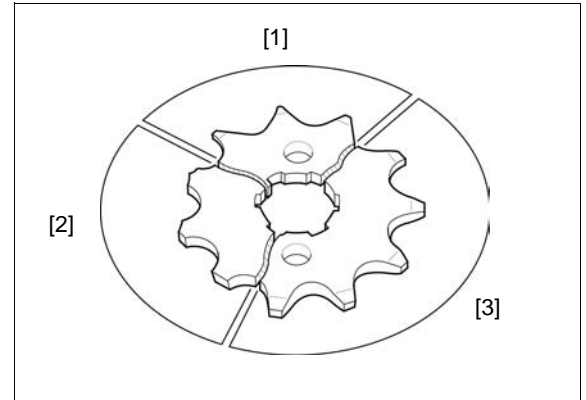

Check the attaching bolts and nuts on the drive and driven sprockets.

If any are loosen, torque them.

TORQUE:

[1] Drive sprocket fixing plate bolt:
12 N·m (1.2 kgf·m, 9 lbf·ft)

[2] Driven sprocket nut:
32 N·m (3.3 kgf·m, 24 lbf·ft)

Install the drive sprocket cover (page 2-5).

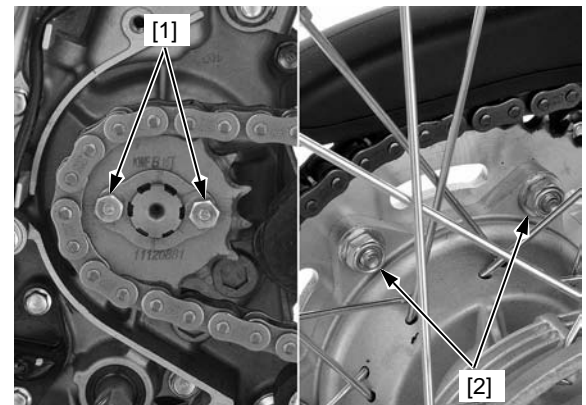

DRIVE CHAIN SLIDER

Remove the drive sprocket cover (page 2-5).

Check the drive chain slider [1] for wear or damage. Replace the drive chain slider if it is worn up to the wear limit.

Refer to procedure for swingarm removal/installation (page 15-13).

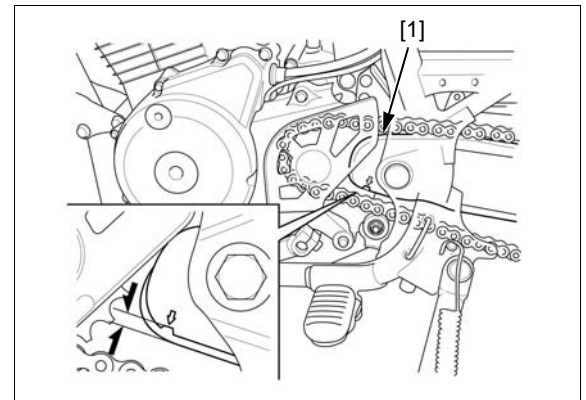

BRAKE FLUID (XR125LK/LEK)

NOTICE

- Spilled fluid can damage painted, plastic or rubber parts. Place a rag over these parts whenever the system is serviced.
- Do not mix different types of fluid, as they are not compatible with each other.
- Do not allow foreign material to enter the system when filling the reservoir.

Turn the handlebar so the reservoir is level and check the front brake fluid reservoir level through the sight glass [1].

- When the fluid level is low (below the "LOWER" level line [2]), check the brake pads for wear (page 3-12). A low fluid level may be due to worn brake pads. If the brake pads are worn, the caliper pistons are pushed out, and this causes a low reservoir level. If the brake pads are not worn and the fluid level is low, check entire system for leaks (page 3-13).

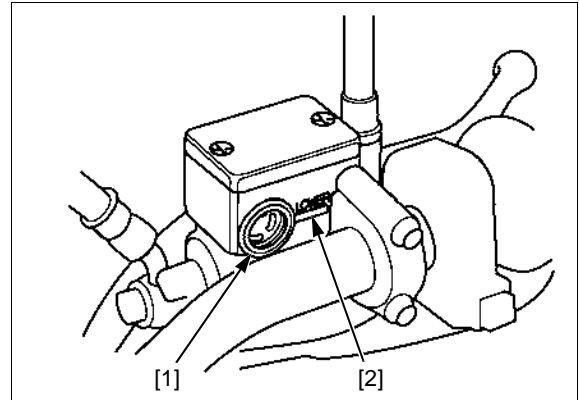

BRAKE SHOES/PADS WEAR

FRONT BRAKE SHOES (XL125LK)

Check the wear indicator position when the brake lever is applied.

If the arrow [1] on the indicator plate aligns with the "△" mark [2] on the brake panel, inspect the brake drum. Replace the brake shoes if the drum I.D. is within the service limit (page 1-8).

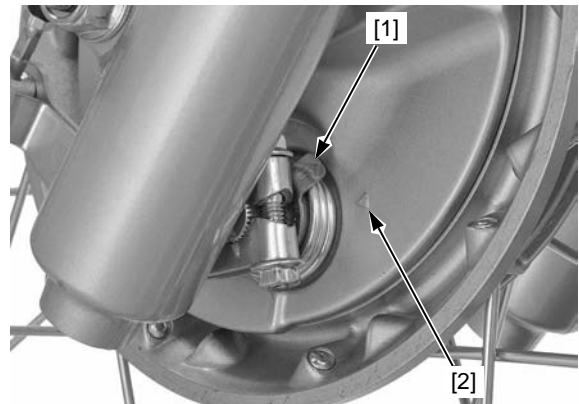

FRONT BRAKE PADS (XR125LK/LEK)

Check the brake pads for wear.

Replace the brake pads [1] if wear limit groove [2] of either pad is worn out (page 16-6).

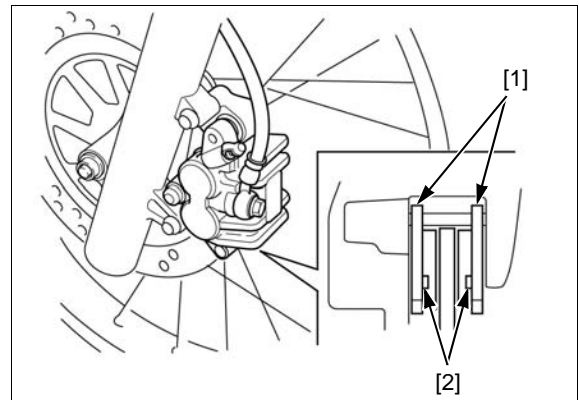

REAR BRAKE SHOES

Check the wear indicator position when the brake pedal is applied.

If the arrow [1] on the indicator plate aligns with the "△" mark [2] on the brake panel, inspect the brake drum. Replace the brake shoes if the drum I.D. is within the service limit (page 1-8).

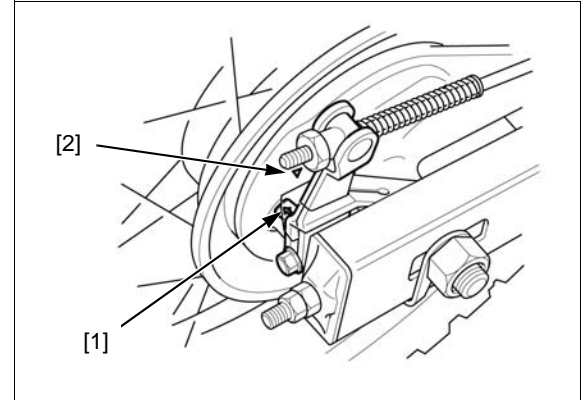

BRAKE SYSTEM

HYDRAULIC BRAKE(XR125LK/LEK)

Firmly apply the brake lever and check that no air has entered the system. If the lever feels soft or spongy when operated, bleed air from the system (page 16-4).

Inspect the brake hose [1] and fittings for deterioration, cracks, damage and signs of leakage. Tighten any loose fittings.

Replace hose and fittings as required.

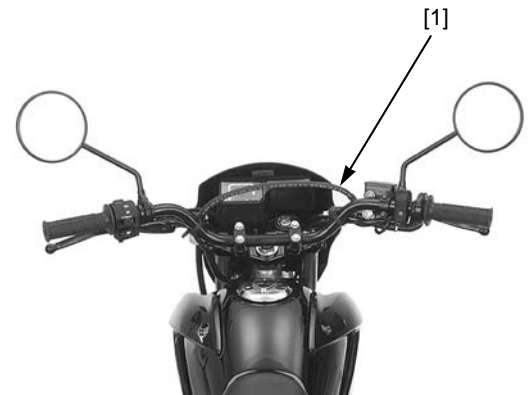

BRAKE LEVER FREEPLAY (XL125LK)

Inspect the brake cable for kinks or damage, and lubricate the cable if necessary.

Measure the brake lever freeplay at the end of the lever.

FREEPLAY: 10 – 20 mm (0.4 – 0.8 in)

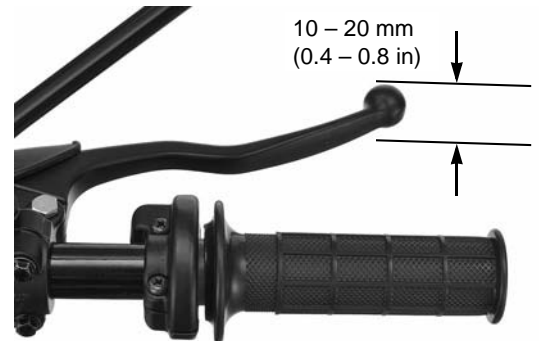

Adjust the front brake lever freeplay by turning the adjusting nut [1].

Make sure the cutout of the adjusting nut is seated on the joint pin [2].

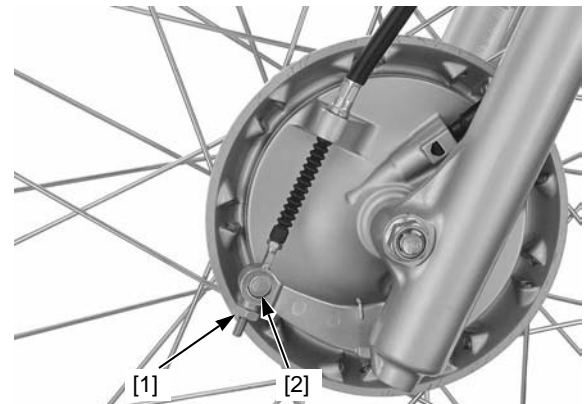

MAINTENANCE

BRAKE PEDAL FREEPLAY

Perform the free play adjustment after adjusting pedal height.

Check the brake pedal free play.

FREEPLAY: 15 – 25 mm (0.6 – 1.0 in)

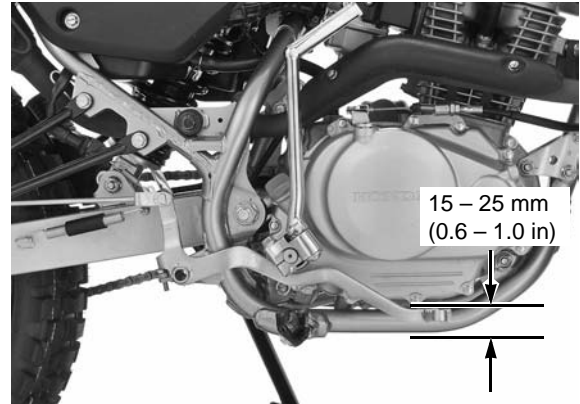

Adjust the freeplay by turning the adjusting nut [1].

Make sure the cutout of the rear brake adjusting nut is seated on the joint pin [2].

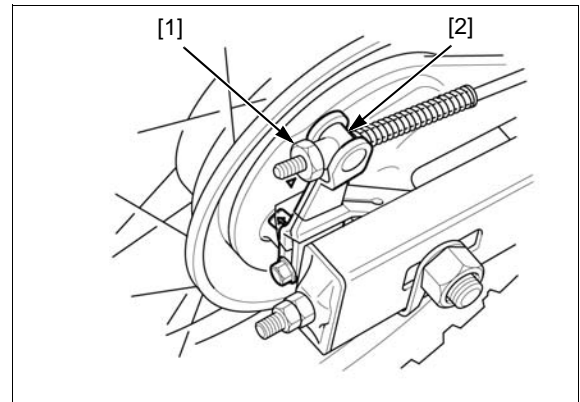

BRAKE PEDAL HEIGHT

Adjust the brake pedal to the desired height.

Loosen the lock nut [1] and turn the adjusting bolt [2] to obtain the pedal height. After adjustment tighten the lock nut.

Adjust the pedal free play (page 3-14).

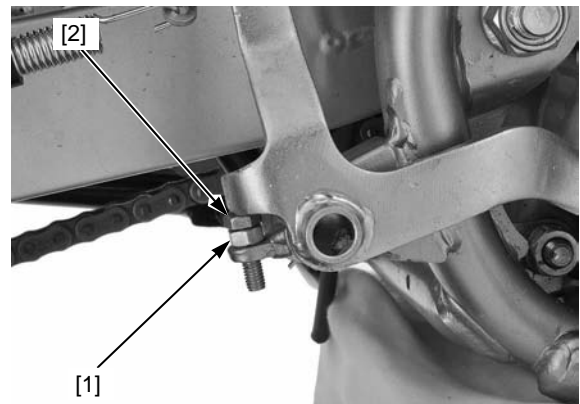

BRAKE LIGHT SWITCH

- Adjust the rear brake light switch after adjusting the brake pedal free play.
- The front brake light switch does not adjusting.

Adjust the rear brake light switch [1] so that the brake light will come on when the brake pedal is pushed down 15 mm (0.6 in), and the brake engagement begins. Hold the switch body and turn the adjusting nut [2]. Do not turn the switch body.

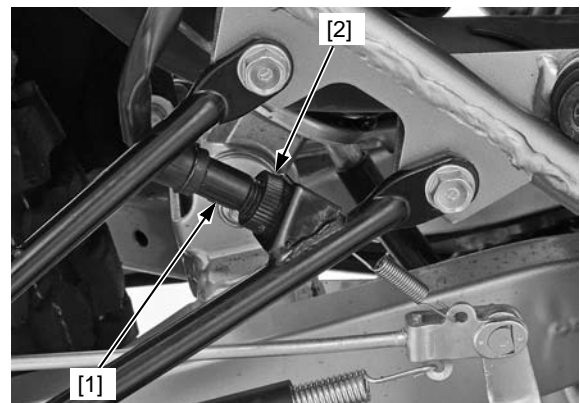

HEADLIGHT AIM

- Adjust the headlight beam as specified by local laws and regulations.

Place the motorcycle on a level surface.
Adjust the headlight beam vertically by turning the adjusting screw [1].

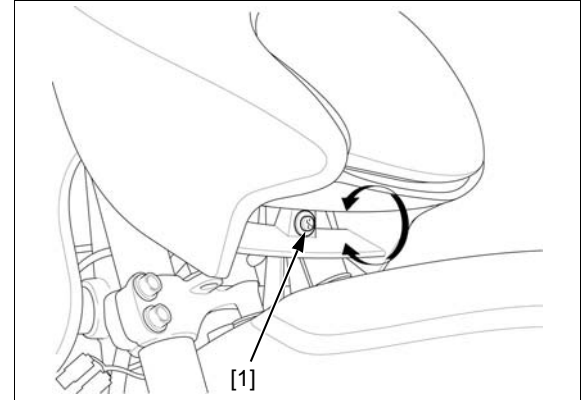

CLUTCH SYSTEM

Inspect the clutch cable for kinks or damage, and lubricate the cable if necessary.

Measure the clutch lever free play at the end of the lever.

FREEPLAY: 10 – 20 mm (0.4 – 0.8 in)

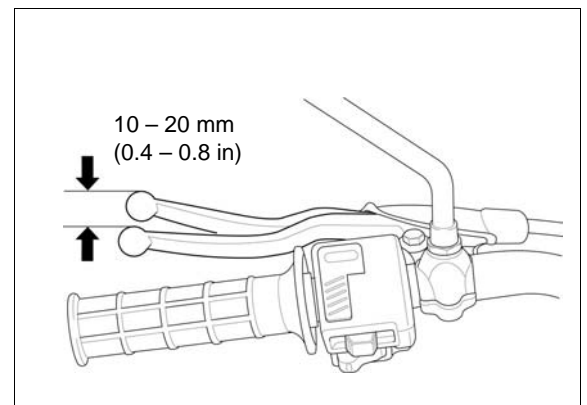

Minor adjustments are made with the upper adjuster at the clutch lever.

Slide the dust cover [1] off, loosen the lock nut [2] and turn the adjuster [3] to obtain the freeplay. Tighten the lock nut and install the dust cover.

NOTICE

The adjuster may be damaged if it is positioned too far out, leaving minimal thread engagement.

If the adjuster is threaded out near the limit and the correct free play cannot be obtained, turn the adjuster all the way in and back out one turn. Tighten the lock nut and make major adjustments as described below.

Major adjustments are made with the lower adjusting nut at the engine.

Loosen the lock nut [1] and turn the adjusting nut [2]. After adjustment is complete, tighten the lock nut while holding the adjusting nut.

Check the clutch operation.
If the free play cannot be obtained, or the clutch slips during the test ride, disassemble and inspect the clutch (page 10-7).

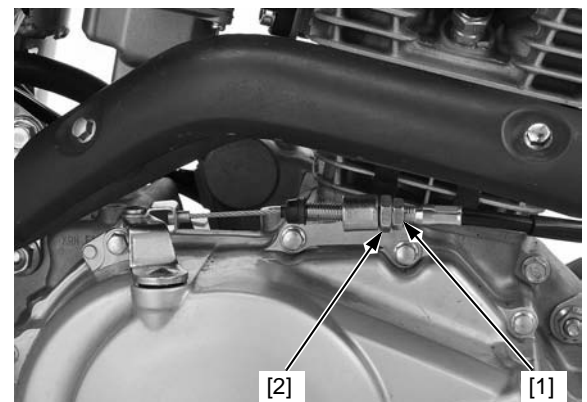
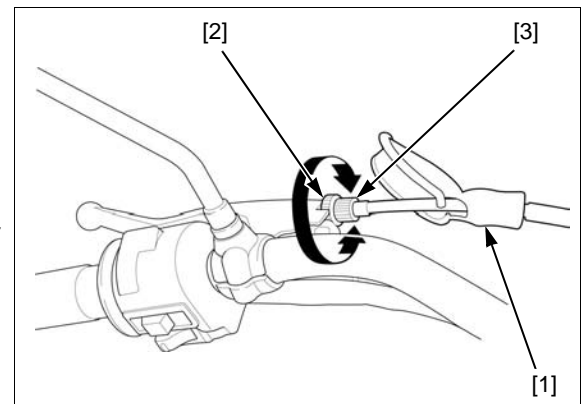

MAINTENANCE

SIDESTAND

Check the sidestand spring [1] for damage or loss of tension.

Check the sidestand [2] operation for freedom of movement and lubricate the sidestand pivot if necessary.

Check that the sidestand pivot bolt and lock nut are tightened. Torque any loose bolt and nut.

Tighten the pivot bolt.

TORQUE: 10 N·m (1.0 kgf·m, 7 lbf·ft)

Tighten the pivot lock nut while holding the pivot bolt.

TORQUE: 39 N·m (4.0 kgf·m, 29 lbf·ft)

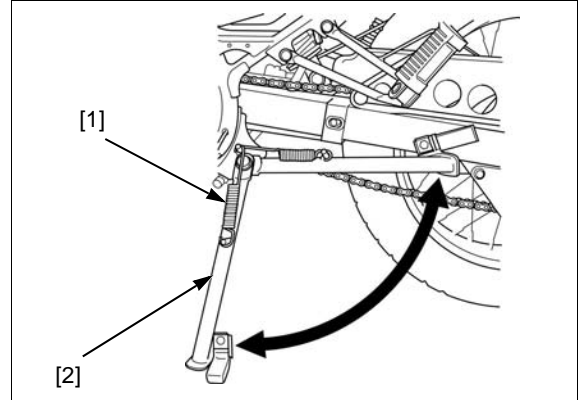

SUSPENSION

FRONT SUSPENSION INSPECTION

Check the action of the forks by applying the front brake and compressing it several times.

Check the entire assembly for leaks, damage or loose fasteners.

Replace damaged components which cannot be repaired.

Tighten all nuts and bolts.

Refer to procedure for the fork service (page 14-13).

REAR SUSPENSION INSPECTION

Check the action of the shock absorber by compressing it several times.

Check the entire shock absorber assembly for signs of leaks, damage or loose fasteners.

Replace damaged components which cannot be repaired.

Tighten all nuts and bolts.

Refer to procedure for the shock absorber service (page 15-11).

Raise the rear wheel off the ground and support the motorcycle securely.

Check for worn swingarm by grabbing the swingarm and attempting to move the wheel side to side.

NUTS, BOLTS, FASTENERS

Check that all chassis nuts and bolts are tightened to their correct torque values (page 1-10).

Check that all cotter pins, safety clips, hose clamps and cable stays are in place and properly secured.

WHEELS/TIRES

Check for worn wheel bearings by grabbing the front and rear wheels, and attempting to move the wheel side to side.

Replace the front wheel bearings if any looseness is noted (page 14-9).

Replace the rear wheel bearings if any looseness is noted (page 15-4).

Making sure that the fork is not allowed to move, raise the front wheel and check for play. Turn the wheel and check that it rotates smoothly with no unusual noises.

If any fault is found, inspect the wheel bearings.

Support the motorcycle securely and raise the rear wheel off the ground.

Check for play in either the wheel or the swingarm pivot. Turn the wheel and check that it rotates smoothly with no unusual noises.

If abnormal conditions are suspected, check the rear wheel bearings.

As the swingarm pivot is also checked, be sure to confirm the location of the play; i.e. from the wheel bearings or the swingarm pivot.

Tire pressure should be checked when the tires are cold.

Check the cold tire pressure.

RECOMMENDED TIRE PRESSURE AND TIRE SIZE:

		XR125LK/LEK		XL125LK	
		FRONT	REAR	FRONT	REAR
Tire pressure kPa (kgf/cm ² , psi)	Driver only	150 (1.5, 22)	150 (1.5, 22)	150 (1.5, 22)	150 (1.5, 22)
	Driver and passenger	150 (1.5, 22)	200 (2.0, 29)	150 (1.5, 22)	225 (2.25, 33)
Tire size		90/90-19M/C (52P)	110/90-17M/C (60P)	70/100-21M/C (44P)	100/90-18M/C (56P)
Tire brand		C6559F (CHENG SHIN)	C6559 (CHENG SHIN)	CM-704 (CHENG SHIN)	CM-705 (CHENG SHIN)

Check the tires for cuts, embedded nails, or other damage.

Check the front wheel (page 14-9) and rear wheel (page 15-4) for trueness.

Measure the tread depth at the center of the tires.

Replace the tires when the tread depth reaches the following limits.

MINIMUM TREAD DEPTH:

FRONT: 3.0 mm (0.12 in)

REAR: 3.0 mm (0.12 in)

Inspect the wheel rims and spokes for damage.

Tighten any loose spokes.

TOOL:

[1] Spoke wrench, 5.8 x 6.1 mm 07701 – 0020300

TORQUE: 3.7 N·m (0.4 kgf·m, 2.7 lbf·ft)

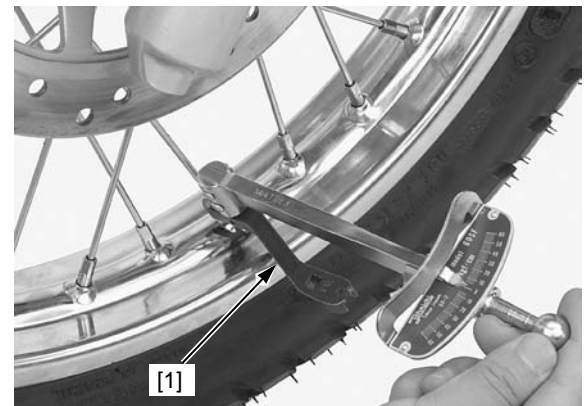

STEERING HEAD BEARINGS

Raise the front wheel off the ground by placing a work stand or box under the engine.

Check that the handlebar moves freely from side to side. Make sure the control cables do not interfere with the handlebar rotation.

If the handlebar moves unevenly, binds, or has vertical movement, inspect the steering head bearings (page 14-22).

MEMO

COMPONENT LOCATION	4-2	IGNITION SYSTEM INSPECTION	4-4
SYSTEM DIAGRAM	4-2	IGNITION TIMING	4-5
SERVICE INFORMATION	4-3	IGNITION COIL	4-6
TROUBLESHOOTING.....	4-3	ICM (IGNITION CONTROL MODULE).....	4-6

IGNITION SYSTEM

COMPONENT LOCATION

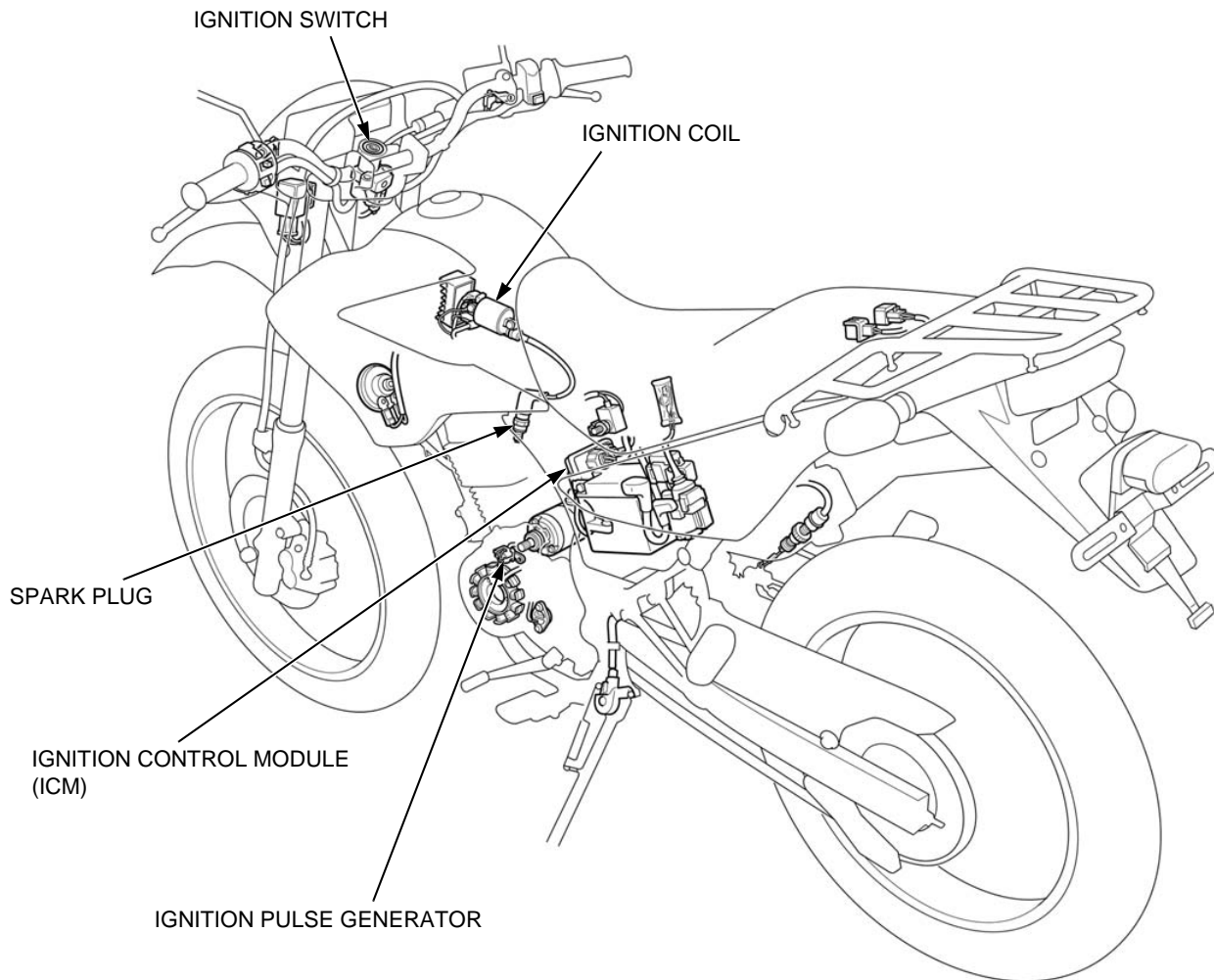

SYSTEM DIAGRAM

NZ TYPE shown:

- Bl ... Black
- R ... Red
- G ... Green
- W ... White
- Y ... Yellow
- Bu ... Blue
- Lg ... Light Green

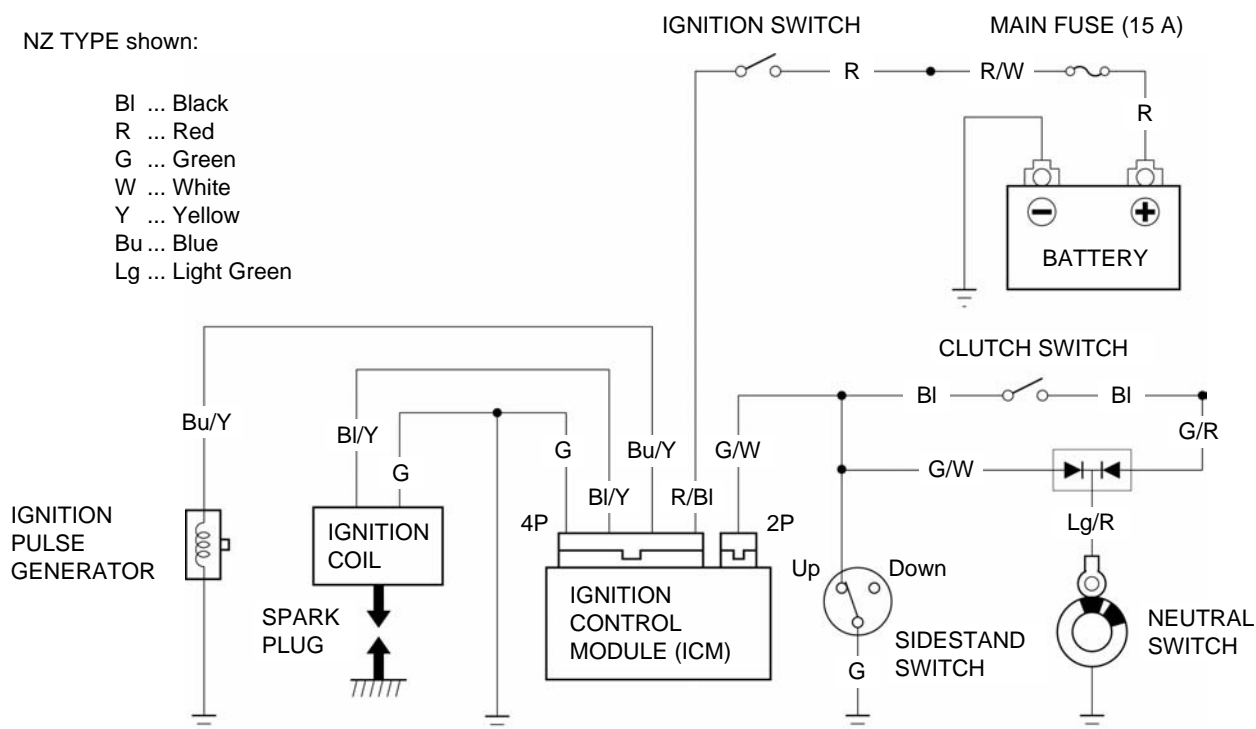

SERVICE INFORMATION

GENERAL

- When servicing the ignition system, always follow the steps in the troubleshooting sequence on (page 4-3).
- The ignition timing cannot be adjusted since the Ignition Control Module (ICM) is factory preset.
- The Ignition Control Module (ICM) may be damaged if dropped. Also if the connector is disconnected when current is flowing, the excessive voltage may damage the module.
- A faulty ignition system is often related to poor connections. Check those connections before proceeding.
- Use spark plug of the correct heat range. Using a spark plug with an incorrect heat range can damage the engine.

TROUBLESHOOTING

Inspect the following before diagnosing the system.

- Loose spark plug cap or spark plug wire connection
- Loose spark plug cap or spark plug wire
- Water got into the spark plug cap (Leaking the ignition coil secondary voltage)

No spark at plug

	Unusual condition	Probable cause (check in numerical order)
Ignition coil primary voltage	Low peak voltage.	<ol style="list-style-type: none"> 1. The multimeter impedance is too low; below 10 MΩ/DCV. 2. Cranking speed is too slow. (Battery is undercharged or operating force of the kickstarter is weak) 3. The sampling time of the tester and measured pulse were not synchronized. (System is normal if measured voltage is over the standard voltage at least once) 4. Poorly connected connectors or an open circuit in the ignition system. 5. Faulty ignition coil. 6. Faulty ignition control module (ICM). (in case when above No. 1 – 5 are normal)
	No peak voltage.	<ol style="list-style-type: none"> 1. Incorrect peak voltage adapter connections. 2. Faulty ignition switch. 3. Loose or poorly connected ICM connector. 4. Open circuit or poor connection in the Red/black wire of the ICM. 5. Open circuit or poor connection in the Green wire of the ICM. 6. Faulty peak voltage adapter. 7. Faulty ignition pulse generator. (Measure the peak voltage) 8. Faulty ICM. (in case when above No.1 – 7 are normal)
	Peak voltage is normal, but no spark jumps at the plug.	<ol style="list-style-type: none"> 1. Faulty spark plug or leaking ignition coil secondary current. 2. Faulty ignition coil.
Ignition pulse generator	Low peak voltage.	<ol style="list-style-type: none"> 1. The multimeter impedance is too low; below 10 MΩ/DCV. 2. Cranking speed is too slow. (Battery is undercharged or operating force of the kickstarter is weak) 3. The sampling time of the tester and measured pulse were not synchronized. (System is normal if measured voltage is over the standard voltage at least once) 4. Faulty ignition pulse generator. (in case when above No.1 – 3 are normal)
	No peak voltage.	<ol style="list-style-type: none"> 1. Faulty peak voltage adapter. 2. Faulty ignition pulse generator.

IGNITION SYSTEM INSPECTION

- If there is no spark at the plug, check all connections for loose or poor contact before measuring the peak voltage.
- Use a commercially available digital multimeter with an impedance of 10 M Ω /DCV minimum.
- The display value differs depending upon the internal impedance of the multimeter.
- If using the Imrie diagnostic tester (model 625), follow the manufacturer's instructions.

Connect the peak voltage adaptor [1] to the digital multimeter [2], or use the Imrie diagnostic tester.

TOOL:

**Imrie diagnostic tester (model 625) or
Peak voltage adaptor 07HGJ-0020100
with commercially available digital multimeter
(impedance 10 M Ω /DCV minimum)**

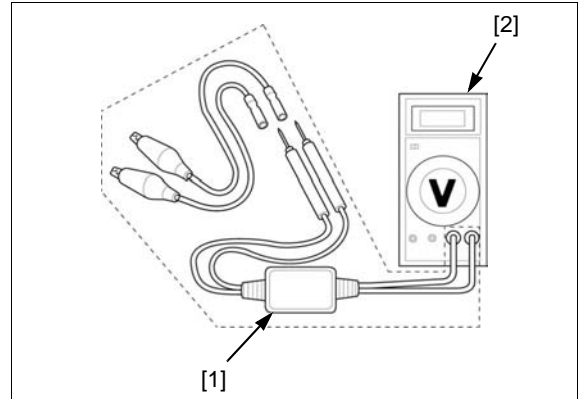

IGNITION COIL PRIMARY PEAK VOLTAGE

- Check all system connections before this inspection. Poor connected connectors can cause incorrect readings.
- Check the cylinder compression and check that the spark plug is installed correctly in the cylinder head.

Disconnect the spark plug cap from the spark plug. Connect a known good spark plug [1] to the spark plug cap and ground it to the cylinder head as done in a spark test.

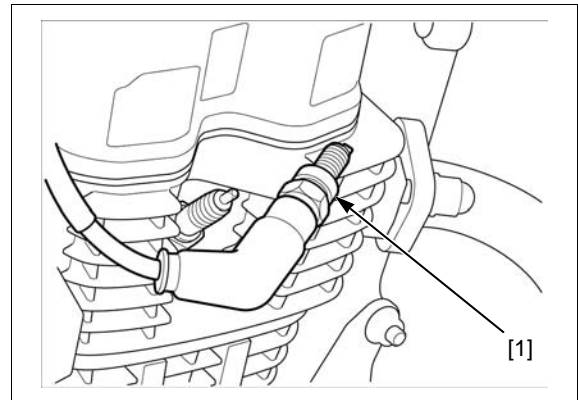

With the ignition coil primary wire connected, connect the peak voltage adaptor [1] or tester probes to the ignition coil primary terminal [2] and body ground.

TOOL:

**Imrie diagnostic tester (model 625) or
Peak voltage adaptor 07HGJ-0020100
with commercially available digital multimeter
(impedance 10 M Ω /DCV minimum)**

CONNECTION:

Black/yellow wire terminal (-) – Body ground (+)

Shift the transmission into neutral.
Turn the ignition switch to "ON".

Crank the engine with the starter motor or kickstarter,
and read ignition coil primary peak voltage.

PEAK VOLTAGE: 100 V minimum

If the peak voltage is lower than the standard value,
follow the checks described in the troubleshooting chart
(page 4-3).

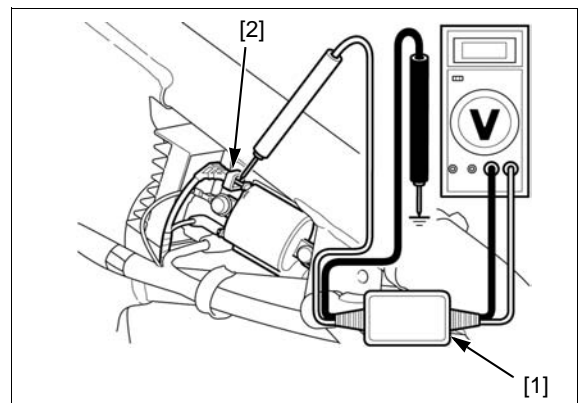

IGNITION PULSE GENERATOR PEAK VOLTAGE

- Check the cylinder compression and check that the spark plug is installed correctly in the cylinder head.

Disconnect the ICM 4P connector.

Connect the peak voltage adaptor [1] or tester probes to the ignition pulse generator wire terminal of the 4P connector [2] and body ground.

TOOL:

**Imrie diagnostic tester (model 625) or
Peak voltage adaptor 07HGJ-0020100
with commercially available digital multimeter
(impedance 10 MΩ/DCV minimum)**

CONNECTION:

Blue/yellow wire terminal (+) – Body ground (-)

Shift the transmission into neutral.

Turn the ignition switch to "ON".

Crank the engine with the starter motor and read ignition pulse generator peak voltage.

PEAK VOLTAGE: 0.7 V minimum

If the peak voltage measured at the ICM connector is abnormal, measure the peak voltage at the alternator connector.

Remove the left side cover (page 2-2).

Disconnect the ignition pulse generator (Blue/yellow) wire connector [1] and connect the peak voltage adaptor [2] probes to the pulse generator side connector and body ground.

In the same manner as at the ICM connector, measure the peak voltage and compare it to the voltage measured at the ICM connector.

- If the peak voltage measured at the ICM is abnormal and the one measured at the ignition pulse generator is normal, the wire harness has an open or short circuit, or loose connection.
- If both peak voltages are abnormal, follow the checks described in the troubleshooting chart (page 4-3).

Refer to procedure for alternator stator replacement (page 11-4).

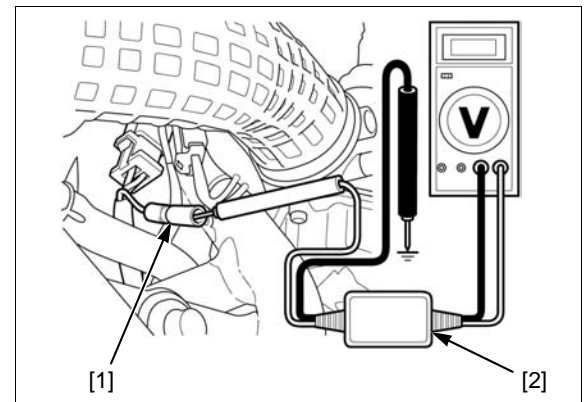
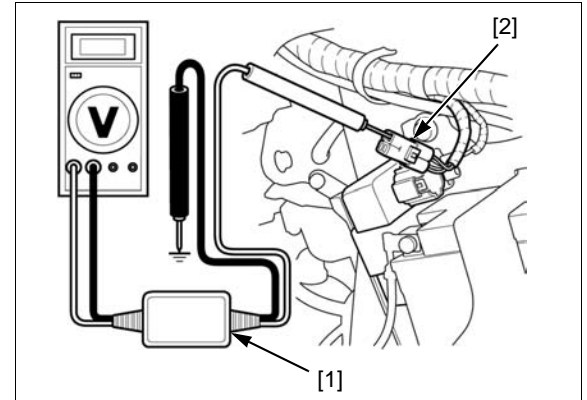

IGNITION TIMING

Warm up the engine.

Read the instructions for timing light operation.

Stop the engine and remove the timing hole cap and O-ring.

Connect a timing light [1] to the spark plug wire.

Start the engine, let it idle and check the ignition timing.

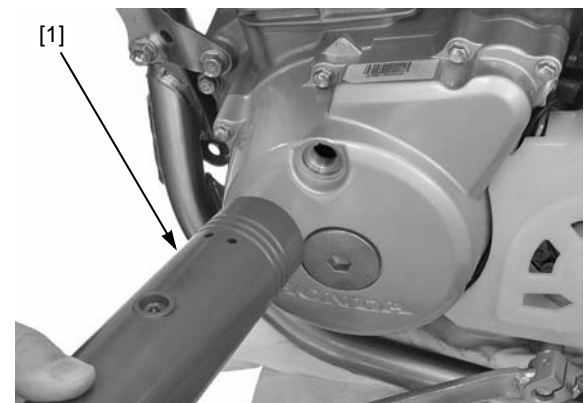

IGNITION SYSTEM

The ignition timing is correct if the "F" mark [1] on the flywheel aligns with the index notch [2] on the left crankcase cover.

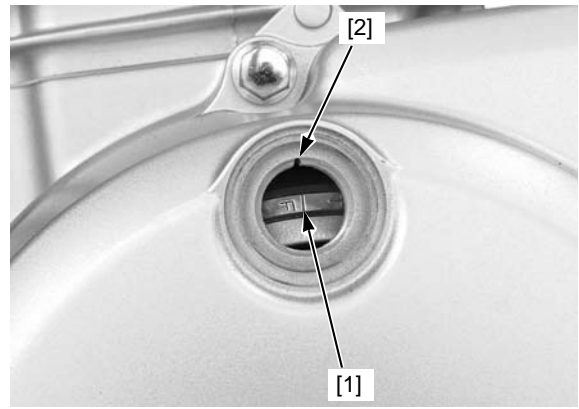

Coat a new O-ring [1] with engine oil and install it onto the timing hole cap [2].

Install the timing hole cap and tighten it.

TORQUE: 10 N·m (1.0 kgf·m, 7 lbf·ft)

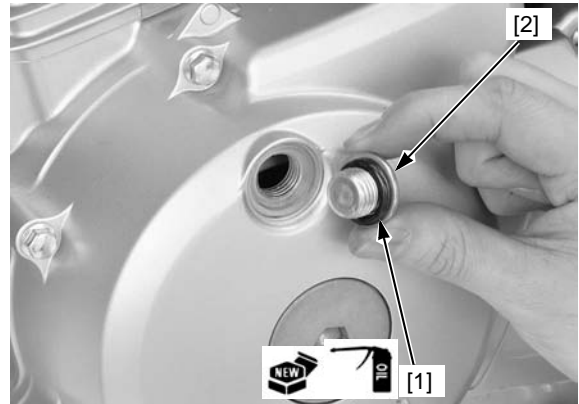

IGNITION COIL

REMOVAL/INSTALLATION

Remove the fuel tank (page 2-4).

Disconnect the spark plug cap from the spark plug.

Disconnect the primary wire connector [1] and ground wire connector [2] from the ignition coil. Remove the bolts [3] and ignition coil [4].

Installation is in the reverse order of removal.

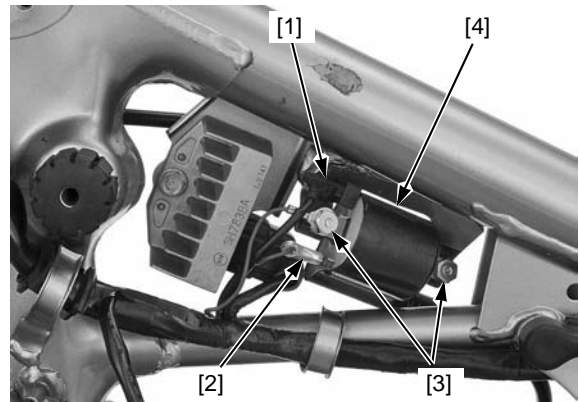

ICM (IGNITION CONTROL MODULE)

REMOVAL/INSTALLATION

Remove the left side cover (page 2-2).

Disconnect the ICM 4P connector [1]. Remove the ICM [2] from the air cleaner housing.

Installation is in the reverse order of removal.

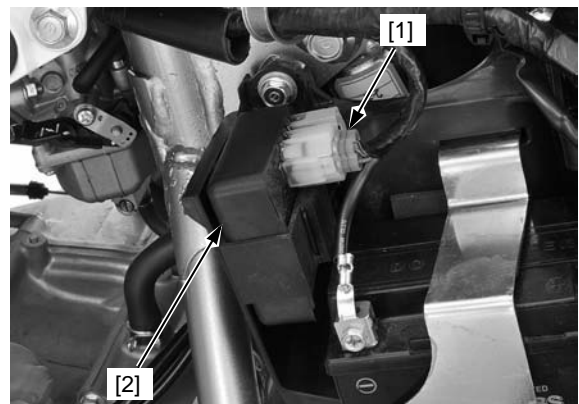

COMPONENT LOCATION	5-2	STARTER MOTOR	5-5
SYSTEM DIAGRAM	5-2	STARTER RELAY	5-7
SERVICE INFORMATION	5-3	NEUTRAL DIODE	5-8
TROUBLESHOOTING	5-3		

ELECTRIC STARTER

COMPONENT LOCATION

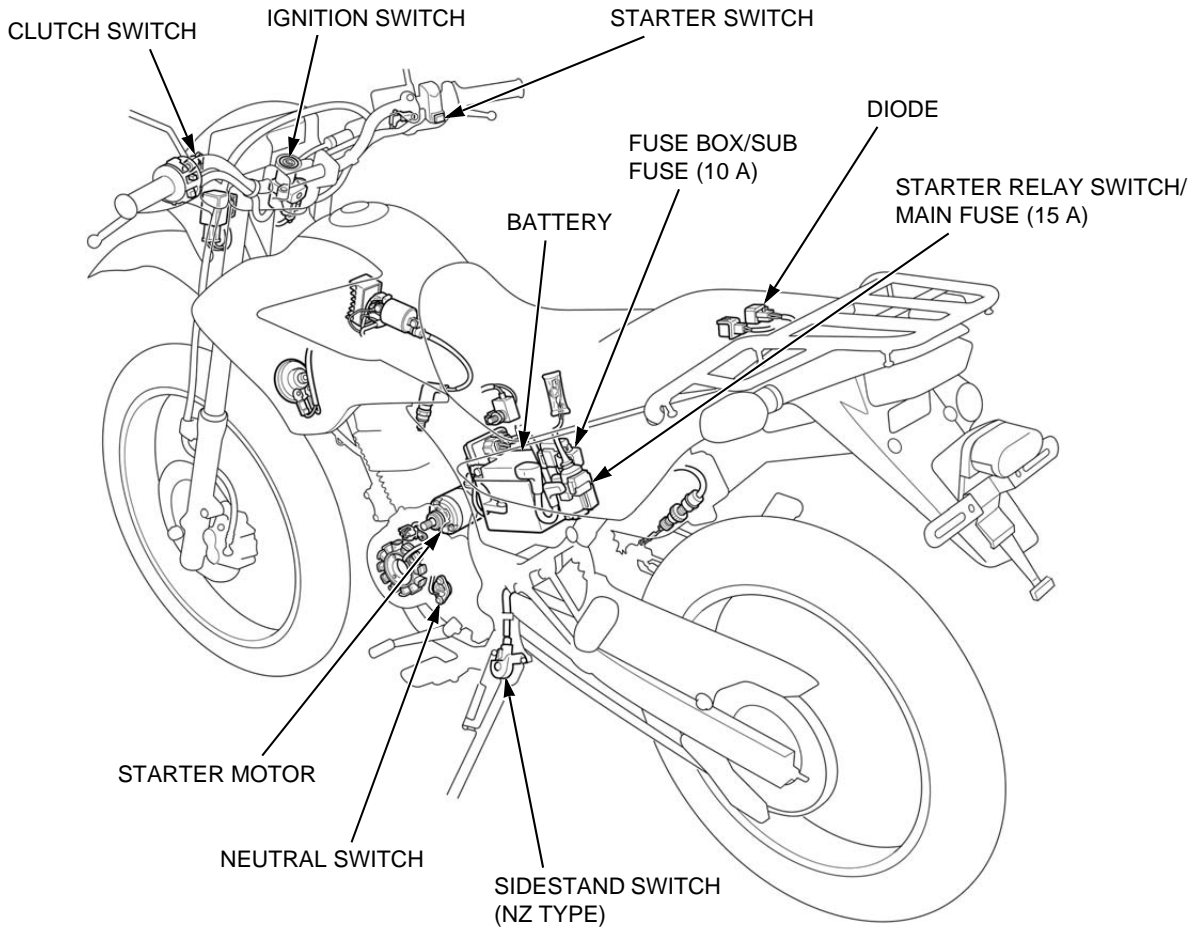

SYSTEM DIAGRAM

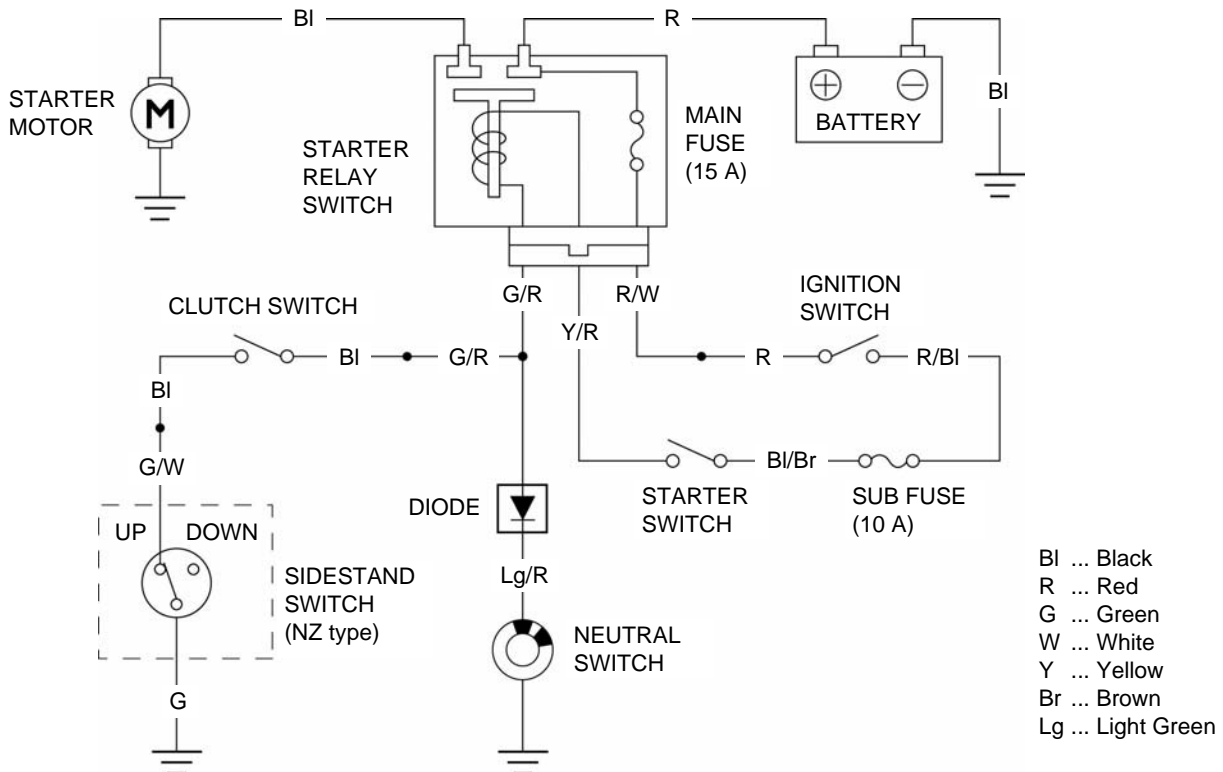

SERVICE INFORMATION

GENERAL

NOTICE

If the current is kept flowing through the starter motor to turn it while the engine is not cranking over, the starter motor may be damaged.

- Always turn the ignition switch to OFF before servicing the starter motor. The motor could suddenly start, causing serious injury.
- The starter motor can be serviced with the engine in the frame.
- When checking the starter system, always follow the steps in the troubleshooting (page 5-3).
- A weak battery may be unable to turn the starter motor quick enough, or supply adequate ignition current.
- Starter clutch servicing (page 11-4)
- Ignition switch servicing (page 18-7)
- Starter switch inspection (page 18-7)
- Clutch switch inspection (page 18-9)
- Neutral switch servicing (page 18-9)

TROUBLESHOOTING

NOTE:

- The starter motor should operate when the transmission is in neutral or when the clutch lever is squeezed.

Starter motor does not turn

1. Fuse Inspection

Check for blown main fuse (15 A) or sub-fuse (10 A).

Is the fuse blown?

YES – Replace the fuse.

NO – GO TO STEP 2.

2. Battery Inspection

Make sure the battery is fully charged and in good condition.

Is the battery in good condition?

YES – GO TO STEP 3.

NO – Charge or replace the battery (page 17-5).

3. Battery Cable Inspection

Check the battery cables for loose or poorly connected terminal, and for an open circuit.

Is the battery cable in good condition?

YES – GO TO STEP 4.

NO –

- Loose or poorly connected battery cables.
- Open circuit in the battery cable.

4. Starter Motor Cable Inspection

Check the starter motor cable for loose or poorly connected terminal, and for an open circuit.

Is the starter motor cable in good condition?

YES – GO TO STEP 5.

NO –

- Loose or poorly connected starter motor cable.
- Open circuit in the starter motor cable.

5. Starter Relay Switch Operation Inspection

Check the operation of the starter relay switch (page 5-7).

Does the starter relay switch click?

YES – GO TO STEP 6.

NO – GO TO STEP 7.

ELECTRIC STARTER

6. Starter Motor Inspection

Connect the starter motor terminal to the battery positive (+) terminal directly. (A large amount of current flows, so do not use a thin wire.)

Does the starter motor turn?

YES – Faulty starter relay switch.

NO – Faulty starter motor.

7. Relay Coil Ground Line Inspection

Check the ground line of the starter relay switch (page 5-7).

Is the ground line normal?

YES – GO TO STEP 8.

NO –

- Faulty neutral diode (page 5-8).
- Faulty neutral switch (page 18-9).
- Faulty clutch switch (page 18-9).
- Loose or poor contact of the related connector terminal.
- Open circuit in the wire harness.

8. Relay Coil Power Input Line Inspection

Check the power input line of the starter relay switch (page 5-7).

Is the power input line normal?

YES – GO TO STEP 9.

NO –

- Faulty ignition switch (page 18-7).
- Faulty starter switch (page 18-7).
- Loose or poor contact of the related connector terminal.
- Open circuit in the wire harness.

9. Starter Relay Switch Inspection

Check the function of the starter relay switch (page 5-8).

Does the starter relay switch function properly?

NO – Faulty starter relay switch.

YES – Loose or poor contact of the starter relay switch connector.

Starter motor turns, but the engine turns slowly

- Low battery voltage
- Poorly connected battery cable
- Poorly connected starter motor cable
- Faulty starter motor
- Poorly connected ground cable terminal

Starter motor turns, but engine does not turn

- Faulty starter clutch
- Damaged or faulty starter gear train

Starter relay switch clicks, but engine does not turn

- Crankshaft does not turn due to engine problems

STARTER MOTOR

REMOVAL

Disconnect the negative (-) cable from the battery (page 17-5).

Slide the rubber cap [1] off and remove the starter motor terminal nut [2], and then disconnect the starter motor cable [3].

Remove the mounting bolts [4], battery (-) cable [5] and starter motor [6] from the crankcase.

Remove the O-ring from the starter motor.

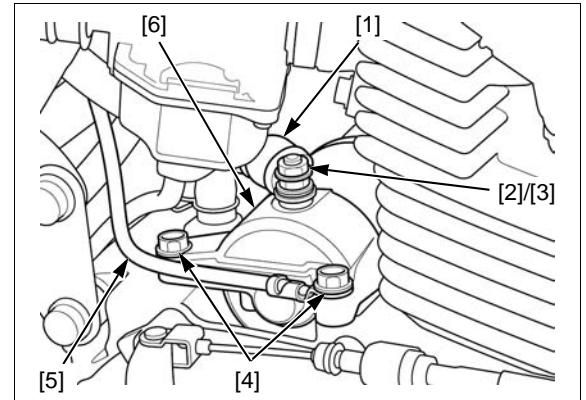

DISASSEMBLY/ASSEMBLY

The coil may be damaged if the magnet pulls the armature against the motor case.

Disassemble and assemble the starter motor as following illustration.

NOTE:

- When disassembling, record the location and number of shims to ensure correct reassembly in their original locations.
- Align the rear cover tab with the motor case groove.

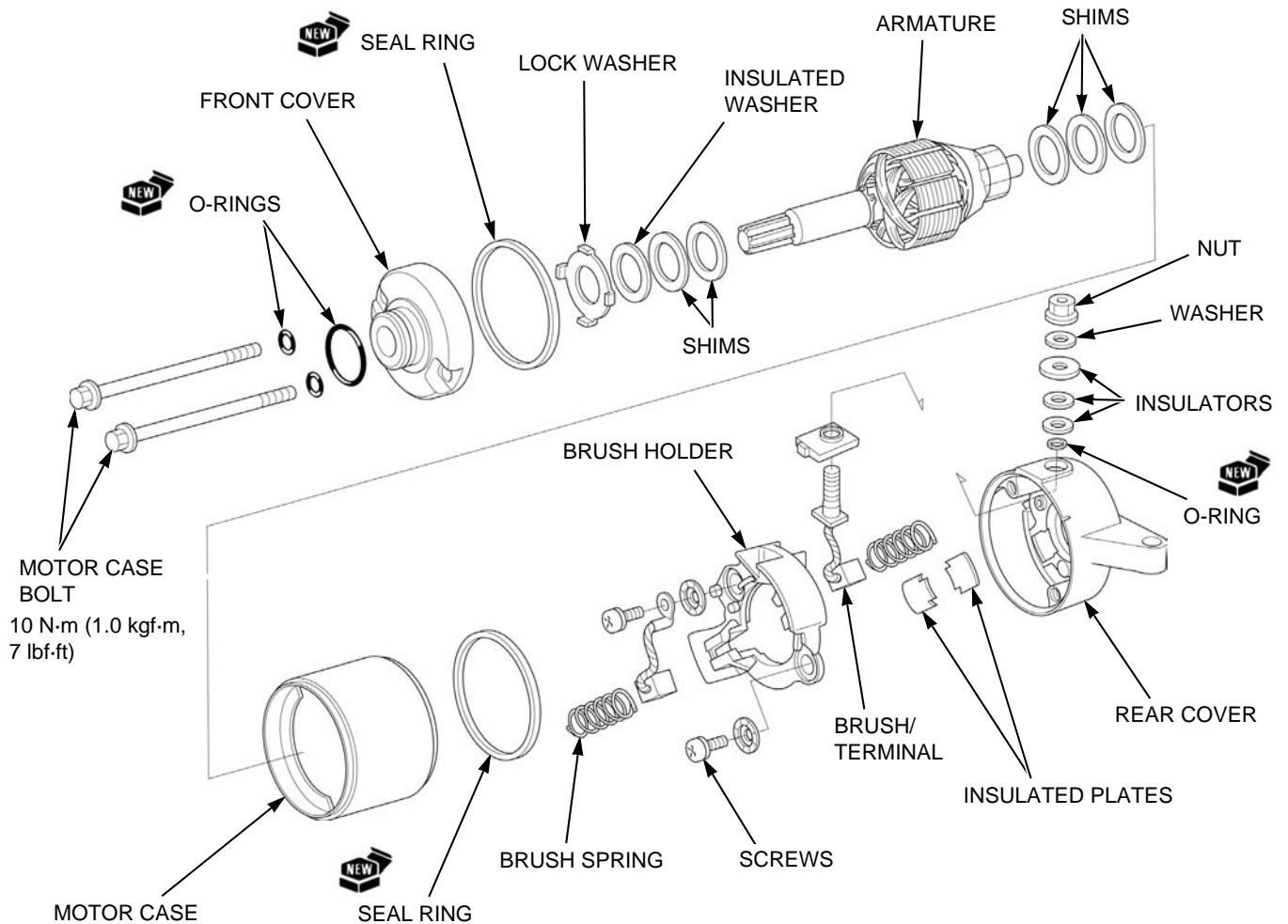

ELECTRIC STARTER

INSPECTION

Check the following:

- Bushing in the motor case for wear or damage
- Oil seal in the front cover for deterioration, wear or damage
- Commutator bars of the armature for discoloration

Check continuity in each part of the starter motor as follows:

- Between pairs of commutator bars; should be continuity
- Between each commutator bar and the armature shaft; should be NO continuity
- Between the brush (+) and cable terminal; should be continuity
- Between the brush (-) and rear cover; should be continuity
- Between the cable terminal and rear cover; should be NO continuity

Inspect the brushes for damage and measure the brush length.

SERVICE LIMIT: 6.5 mm (0.26 in)

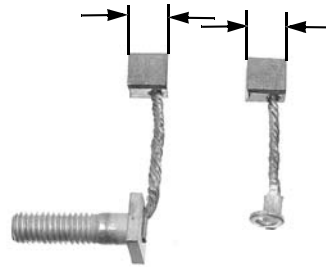
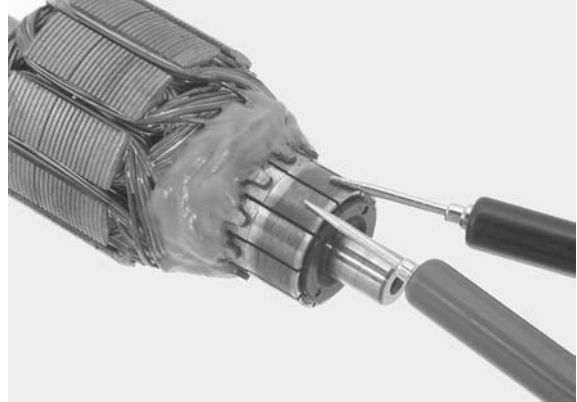

INSTALLATION

Coat a new O-ring [1] with clean engine oil and install it into the groove of the starter motor [2].

Install the starter motor to the crankcase.

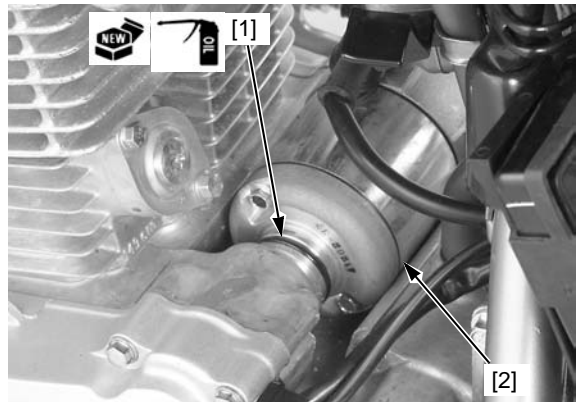

Install the mounting bolts [1] with the battery (-) cable [2] as shown, and tighten the bolts.

Install the starter motor cable [3] and terminal nut [4] onto the motor terminal and tighten the nut as specified. Install the rubber cap [5] over the terminal properly.

Connect the negative (-) cable to the battery (page 17-5).

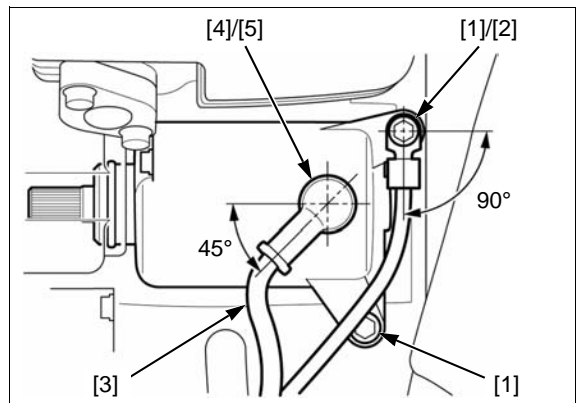

STARTER RELAY

REMOVAL/INSTALLATION

Disconnect the negative (-) cable from the battery (page 17-5).

Disconnect the starter relay switch 4P (Red) connector [1].

Remove the nuts [2], battery cable [3] and starter motor cable [4] from the starter relay switch [5].

Remove the starter relay switch from the stays of the air cleaner housing.

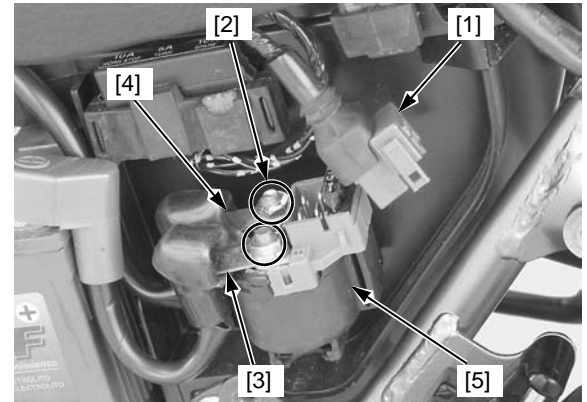

OPERATION INSPECTION

Remove the left side cover (page 2-2).

Shift the transmission into neutral.

Turn the ignition switch to "ON" and push the starter switch.

The coil is normal if the starter relay switch [1] clicks.

If you don't hear the switch click, inspect the relay switch circuits (page 5-7).

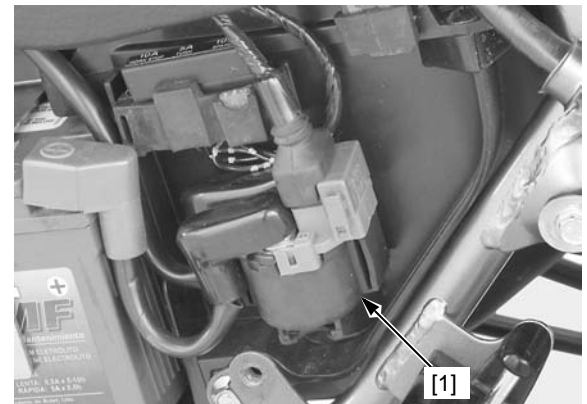

CIRCUIT INSPECTION

Remove the left side cover (page 2-2).

Inspect the starter relay circuit as follows:

GROUND LINE

Turn the ignition switch to "OFF".

Disconnect the starter relay switch 4P (Red) connector [1].

Check for continuity between the Green/red wire terminal of the wire harness side connector and ground.

If there is continuity when the transmission is in neutral or when the clutch lever is squeezed, the ground circuit is normal.

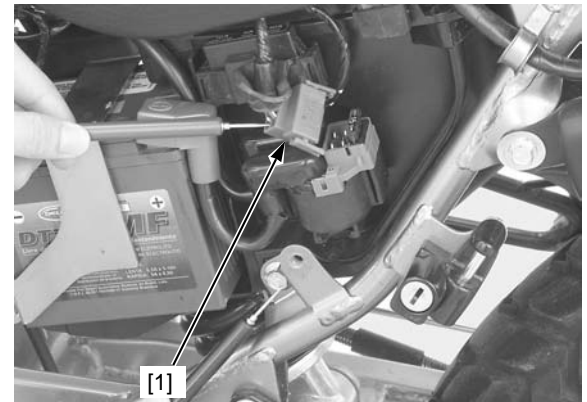

POWER INPUT LINE

Connect the starter relay switch 4P (Red) connector [1].

Turn the ignition switch to "ON".

Measure the voltage between the Yellow/red wire terminal (+) and ground (-).

If the battery voltage appears only when the starter switch is pressed, the circuit is normal.



ELECTRIC STARTER

FUNCTION INSPECTION

Remove the starter relay switch (page 5-7).

Connect an ohmmeter [1] to the starter relay switch [2] cable terminals.

Connect the fully charged 12 V battery [3] to the relay switch connector terminals.

**CONNECTIONS: Battery (+) terminal – Yellow/red
Battery (-) terminal – Green/red**

There should be continuity between the cable terminals while the battery is connected, and no continuity when the battery is disconnected.

Install the starter relay switch (page 5-7).

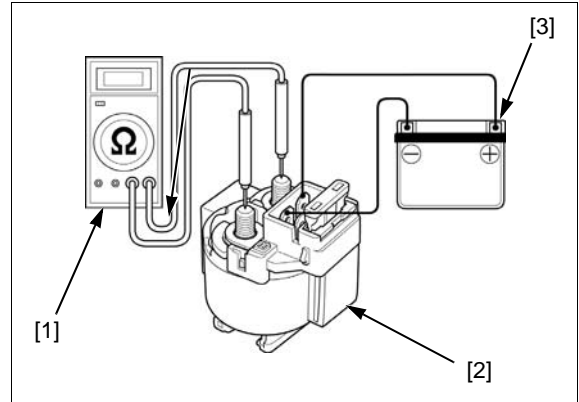

NEUTRAL DIODE

INSPECTION

Remove the rear cowl (page 2-3).

Remove the neutral diode [1] from the connector boot.

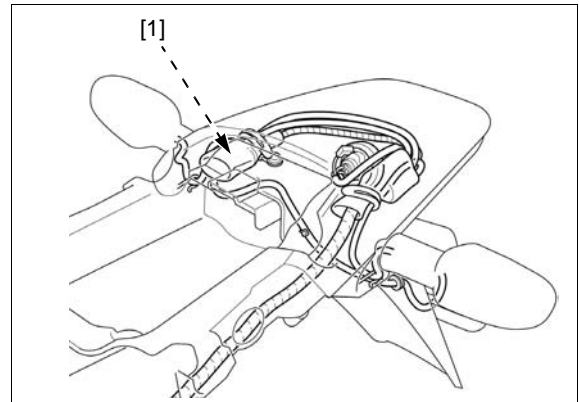

EXCEPT NZ TYPE:

Check for continuity between the diode terminals. When there is continuity, a small resistance value will register.

If there is continuity in one direction, the neutral diode is normal.

Install the neutral diode in the reverse order of removal.

EXCEPT NZ TYPE:

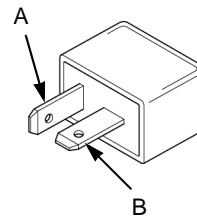

NZ TYPE:

Check for continuity between the diode terminals. When there is continuity, a small resistance value will register.

If there is continuity in one direction, the neutral diode is normal.

Install the neutral diode in the reverse order of removal.

NZ TYPE:

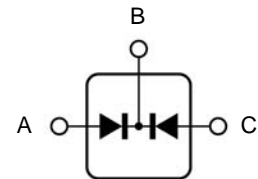
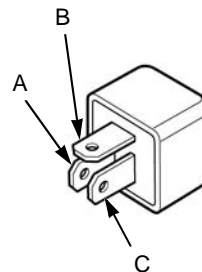

SYSTEM COMPONENTS.....	6-2	CARBURETOR	6-5
SERVICE INFORMATION	6-2	CARBURETOR HEATER (EXCEPT CO, III LA TYPES).....	6-10
TROUBLESHOOTING.....	6-3	PILOT SCREW ADJUSTMENT	6-12
AIR CLEANER HOUSING.....	6-4	SECONDARY AIR SUPPLY SYSTEM (XR125LK/LEK)	6-13

SYSTEM COMPONENTS

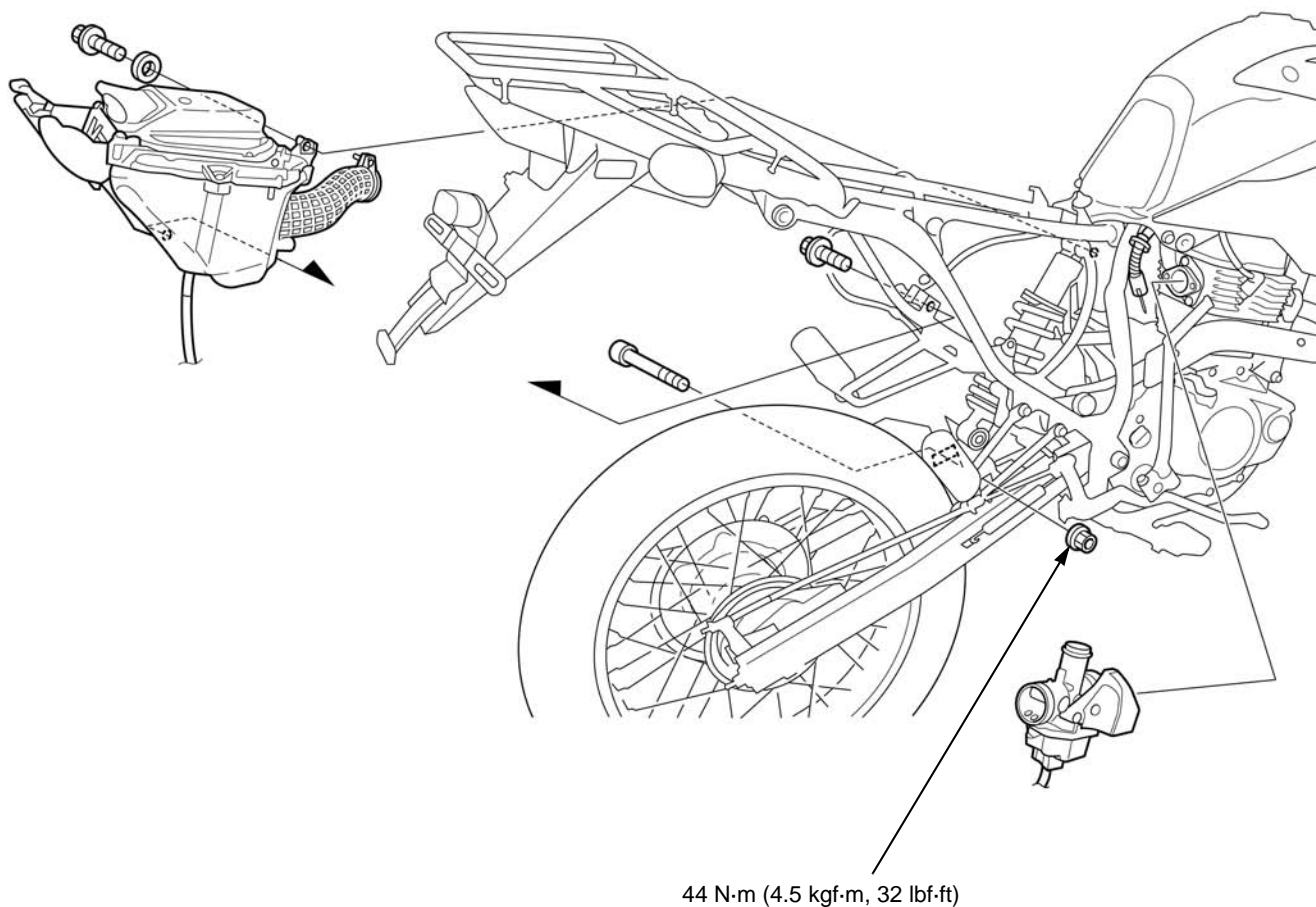

SERVICE INFORMATION

GENERAL

- Bending or twisting the control cable will impair smooth operation and could cause the cable to stick or bind, resulting in loss of vehicle control.
- Work in a well ventilated area. Smoking or allowing flames or sparks in the work area or where gasoline is stored can cause a fire or explosion.
- When disassembling the fuel system parts, note the locations of the O-rings. Replace them with new ones on reassembly.
- Before removing the carburetor, place an approved gasoline container under the carburetor drain hose, loosen the drain screw and drain the carburetor.
- After removing the carburetor, wrap the intake port of the engine with a shop towel or cover it with pieces of tape to prevent any foreign material from dropping into the engine.
- If the vehicle is to be stored for more than one month, drain the float chamber. Fuel left in the float chamber may cause clogged jets, resulting in hard starting or poor driveability.

TROUBLESHOOTING

Engine cranks but won't start

- No fuel in tank
- No fuel to carburetor
 - Clogged fuel strainer
 - Clogged fuel line
 - Clogged fuel tank breather hose
- Too much fuel getting to the engine
 - Clogged air cleaner
 - Flooded carburetor
- Intake air leak
- Contaminated/deteriorated fuel
 - Clogged jets
- Improper choke operation
- Improper throttle operation
- No spark at plug (faulty ignition system – page 4-3)

Lean mixture

- Clogged fuel jets
- Faulty float valve
- Float level too low
- Restricted fuel line
- Clogged carburetor air vent hose
- Restricted fuel tank breather hose
- Intake air leak
- Faulty throttle valve

Rich mixture

- Choke valve closed
- Clogged air jets
- Faulty float valve
- Float level too high
- Dirty air cleaner
- Worn jet needle or needle jet

Engine stalls, hard to start, rough idling

- Restricted fuel line
- Fuel mixture too lean/rich
- Contaminated/deteriorated fuel
 - Clogged jets
- Intake air leak
- Misadjusted idle speed
- Restricted fuel tank breather hose
- Dirty air cleaner
- Misadjusted pilot screw
- Faulty ignition system (page 4-3)

Afterburn when engine braking is used

- Lean mixture in slow circuit
- Faulty PAIR control valve
- Faulty PAIR check valve
- Clogged hose of the PAIR system
- Faulty ignition system (page 4-3)

Backfiring or misfiring during acceleration

- Lean mixture
- Faulty ignition system (page 4-3)

Poor performance (driveability) and poor fuel economy

- Clogged fuel system
- Fuel mixture too lean
- Faulty ignition system (page 4-3)

AIR CLEANER HOUSING

REMOVAL/INSTALLATION

Raise the rear wheel off the ground by placing a box or work stand under the engine.

Remove the following:

- Side covers (page 2-2)
- Seat (page 2-2)
- Muffler (page 2-6)
- Battery (page 17-5)
- Ignition control module (ICM) (page 4-6)
- Starter relay switch [1]
- Fuse box [2]

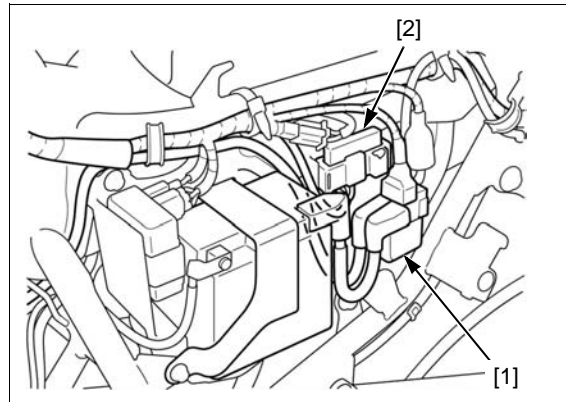

Loosen the connecting boot band screw [1].
Disconnect the crankcase breather hose [2] and carburetor air vent hose [3].

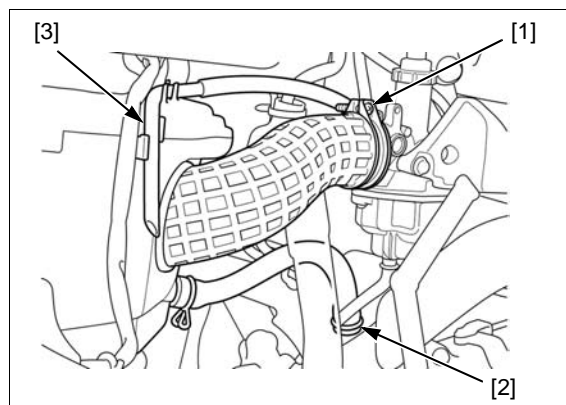

Remove the shock absorber lower mounting bolt [1] and nut [2].
Remove the air cleaner housing mounting bolts [3] and washer [4].
Remove the air cleaner housing [5] to the backward.

Installation is in the reverse order of removal.

TORQUE:

- Shock absorber lower mounting nut:**
44 N·m (45 kgf·m, 32 lbf·ft)

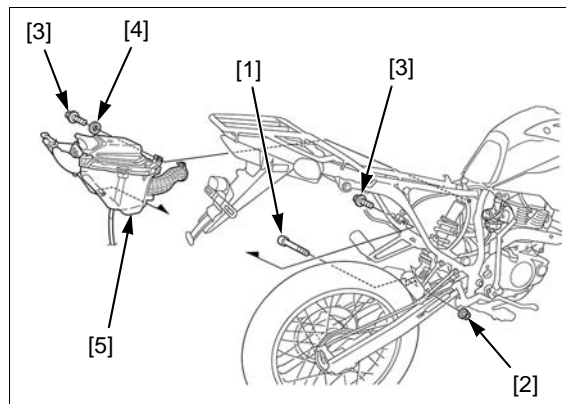

CARBURETOR

REMOVAL

THROTTLE VALVE

Remove the following:

- Side cover (page 2-2)
- Side shroud (page 2-4)

Loosen the carburetor top [1].

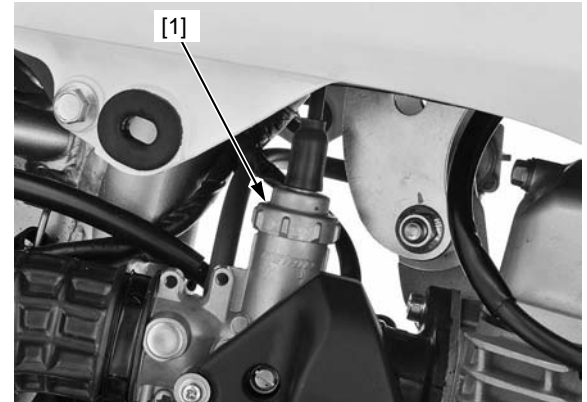

Be careful not to damage the jet needle [1] when removing the throttle valve [2] from the carburetor body.

Remove the carburetor top and throttle valve/jet needle.

Remove the throttle cable [3] from the throttle valve while compressing the throttle valve spring [4].

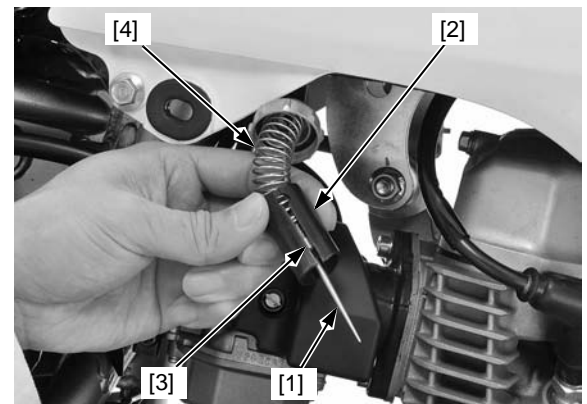

Turn the jet needle retainer [1] counterclockwise.

Remove the jet needle retainer and jet needle [2] from the throttle valve [3].

Remove the spring [4] from the jet needle retainer.

Check the throttle valve and jet needle for scratches, wear or damage.

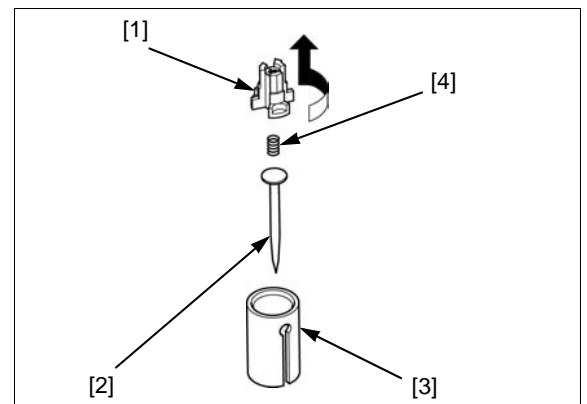

CARBURETOR BODY

Turn the fuel valve "OFF" and disconnect the fuel hose [1] from the fuel valve.

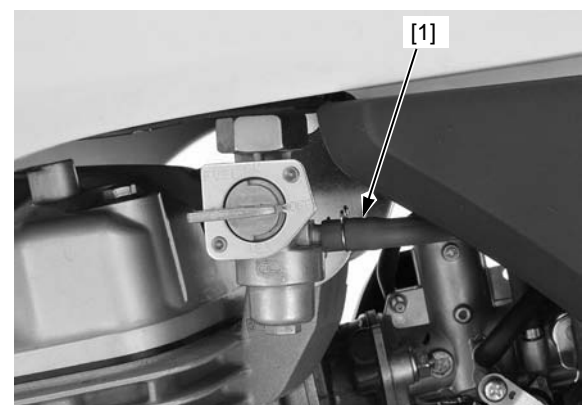

FUEL SYSTEM

Except CO, III LA types: Remove the screw [1] and carburetor heater cover [2].

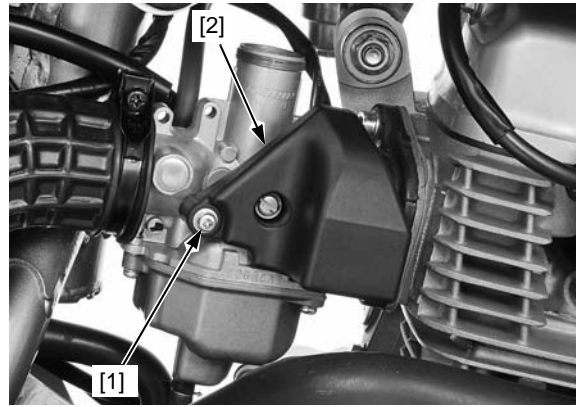

Except CO, III LA types: Disconnect the carburetor heater connector [1] and ground wire connector [2].

Release the carburetor heater wire from the clamp [3].

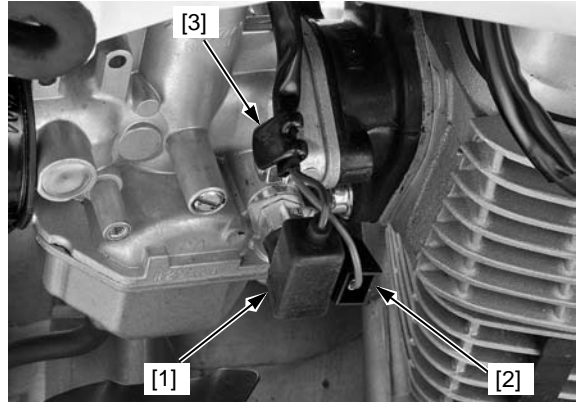

Loosen the connecting boot band screw [1]. Remove the carburetor mounting nuts [2] and wire clamp [3], then remove the carburetor [4] from the insulator.

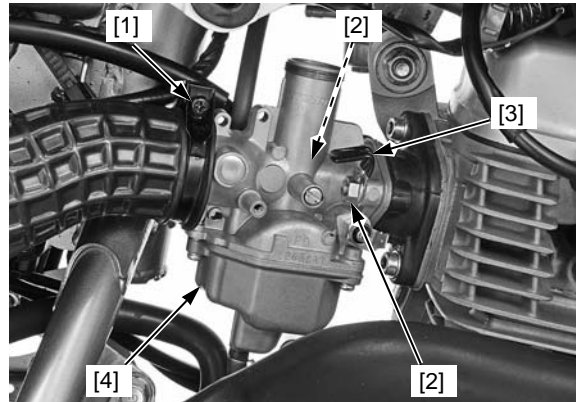

**DISASSEMBLY/ASSEMBLY/
INSPECTION**

Disassemble and assemble the carburetor as following illustration.

NOTE:

- Handle all jets with care. They can easily be scored or scratched.
- Blow open each air and fuel passage in the carburetor body with compressed air.

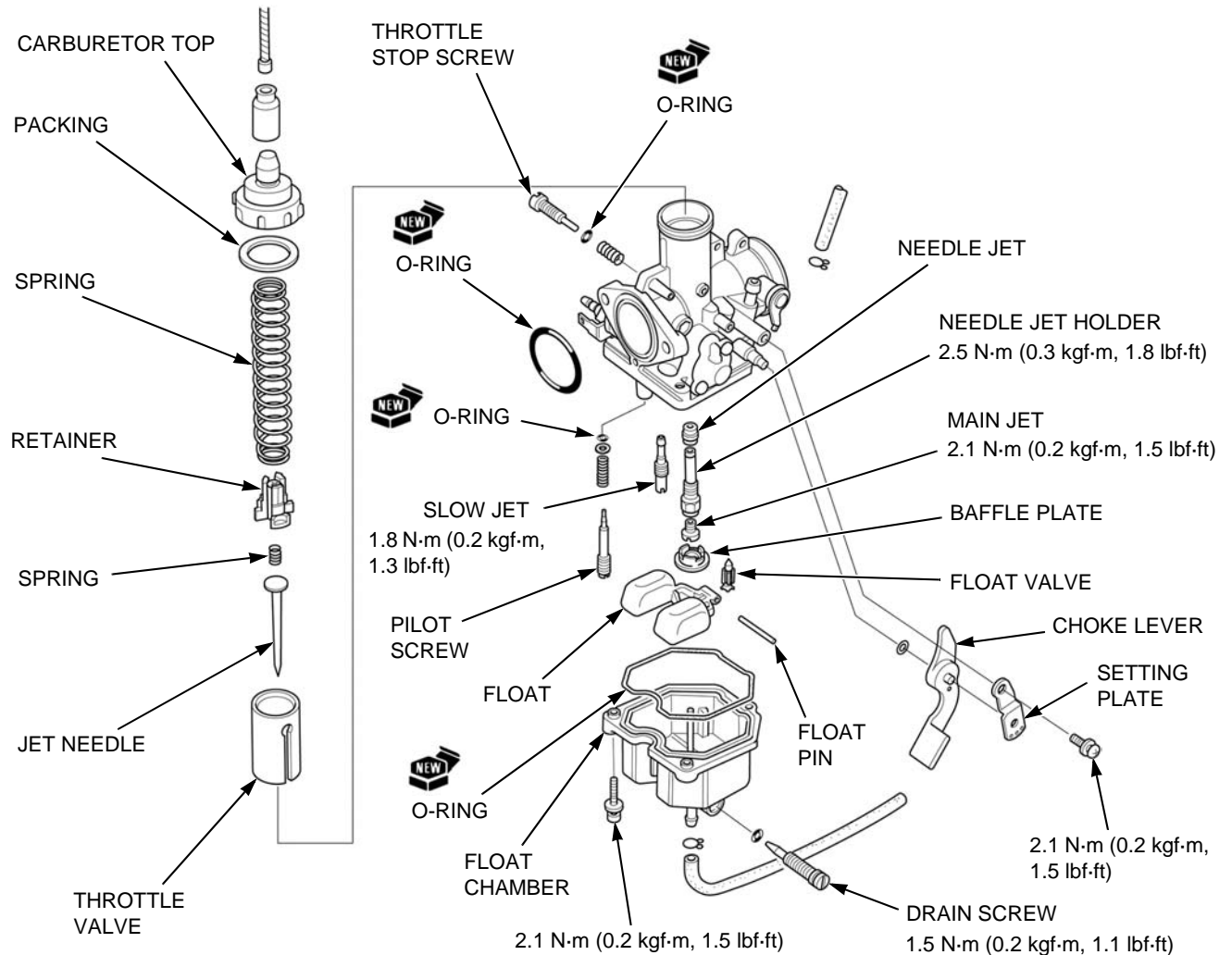

**AIR CUT-OFF VALVE REMOVAL/INSTALLATION
(XR125LK/LEK)**

Remove the two screws [1].
Hold the air cut-off valve cover, or the compression spring will jump out of the carburetor.

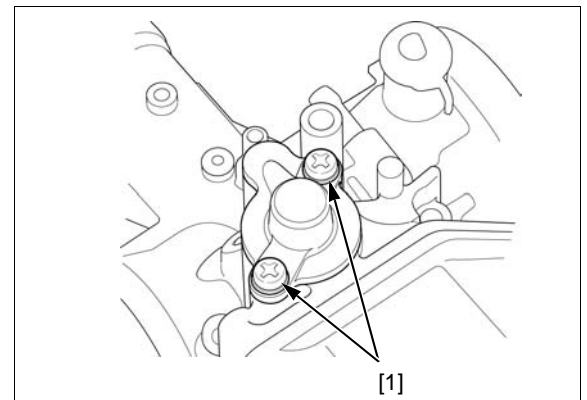

FUEL SYSTEM

Remove the air cut-off valve cover [1], spring [2], diaphragm [3] and O-ring [4].

Check the following:

- Diaphragm for pin holes, deterioration or damage
- O-ring for damage
- Spring for deterioration
- Needle of diaphragm for wear
- Air passages for clogging

Installation is in the reverse order of removal.

- Be sure that the diaphragm and O-ring do not interfere with the cover.

TORQUE: 2.1 N·m (0.2 kgf·m, 1.5 lbf·ft)

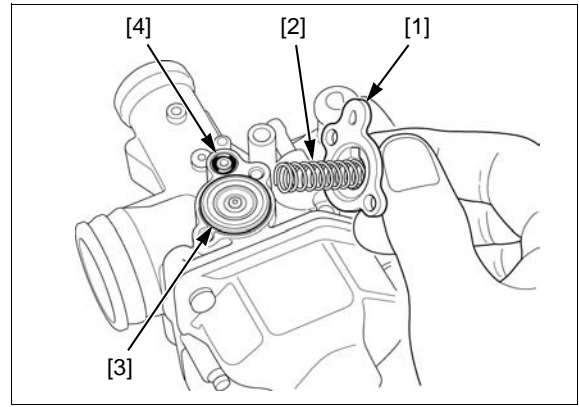

FLOAT LEVEL INSPECTION

With the float valve seated and the float arm just touching the valve, measure the float level with the special tool as shown.

FLOAT LEVEL: 14 mm (0.6 in)

TOOL:

[1] Carburetor float level gauge 07401-0010000

The float cannot be adjusted.

Replace the float assembly if the float level is beyond the specified limit.

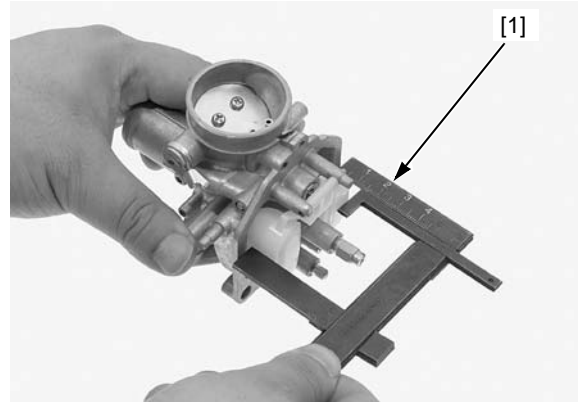

INSTALLATION

CARBURETOR BODY

Install a new O-ring [1] into the groove of the carburetor body.

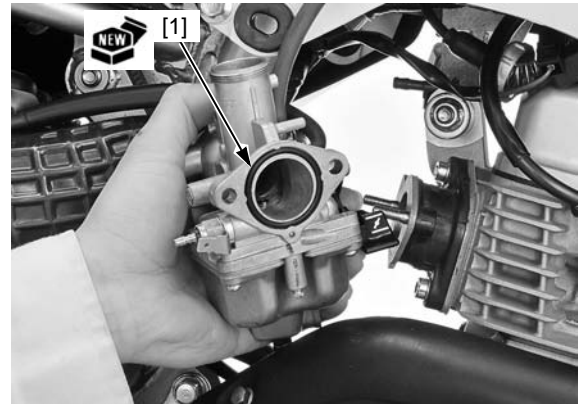

Install the carburetor [1] to the carburetor connecting boot.

Install the carburetor mounting nuts [2] with the wire clamp [3], then tighten the nuts securely.

Tighten the air cleaner connecting boot band screw [4].

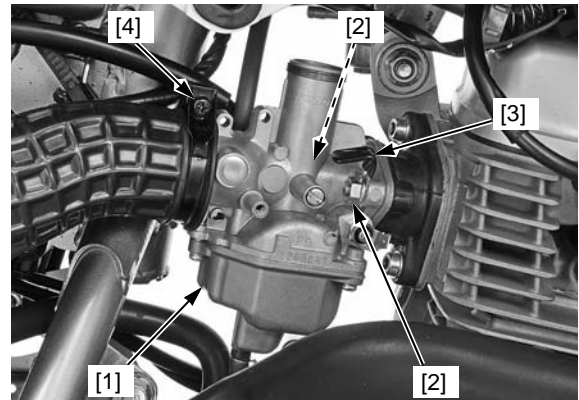

Except CO, III LA types: Connect the carburetor heater connector [1] and ground wire connector [2].
Secure the carburetor heater wire with the wire clamp [3].

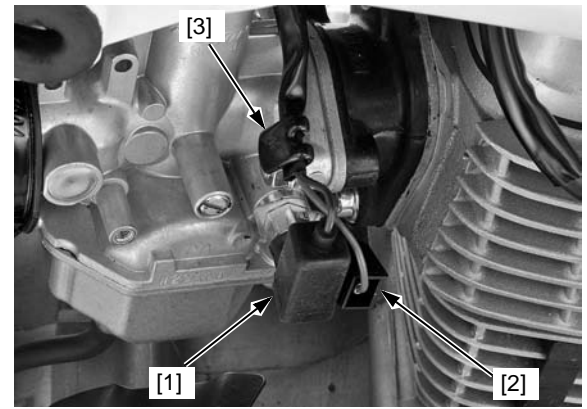

Except CO, III LA types: Install the carburetor heater cover [1] and tighten the screw [2] securely.

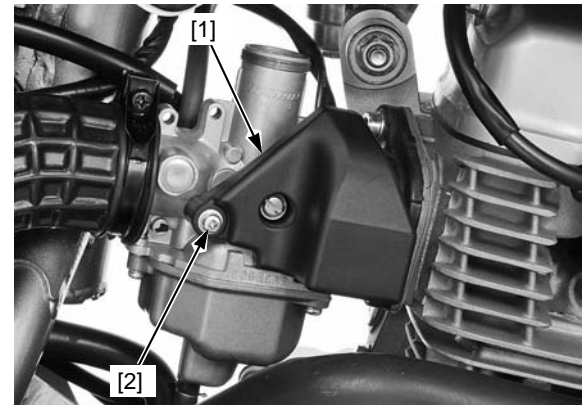

Connect the fuel hose [1] to the fuel valve.
After installing the carburetor, check the following:

- Throttle grip free play (page 3-3)
- Engine idle speed (page 3-8)
- Pilot screw adjustment (page 6-12)

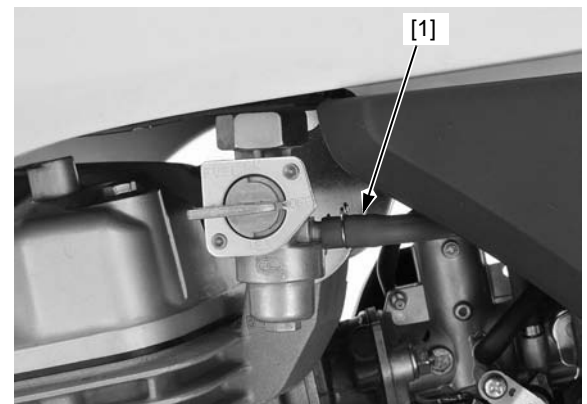

THROTTLE VALVE

Install the spring [1] into the jet needle retainer [2].
Install the jet needle [3] and retainer to the throttle valve [4].
Turn the jet needle retainer clockwise and lock it.

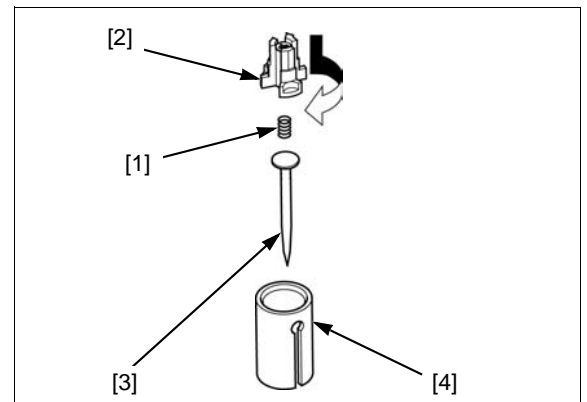

FUEL SYSTEM

Install the throttle valve spring [1] onto the throttle cable [2].
Connect the throttle cable to the throttle valve [3] while compressing the throttle valve spring.

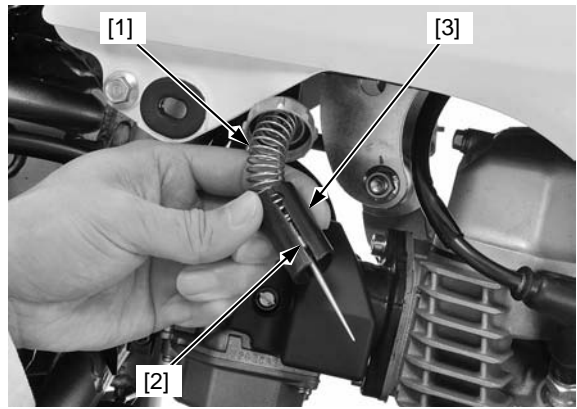

Be careful not to damage the jet needle when installing the throttle valve [1] into the carburetor body.

Install the throttle valve while aligning its cut-out [2] with the throttle stop screw [3].

Tighten the carburetor top securely.

Install the following:

- Right side cover (page 2-2)
- Right side shroud (page 2-4)

After installing the throttle valve, check the following.

- Throttle grip free play (page 3-3)
- Engine idle speed (page 3-8)

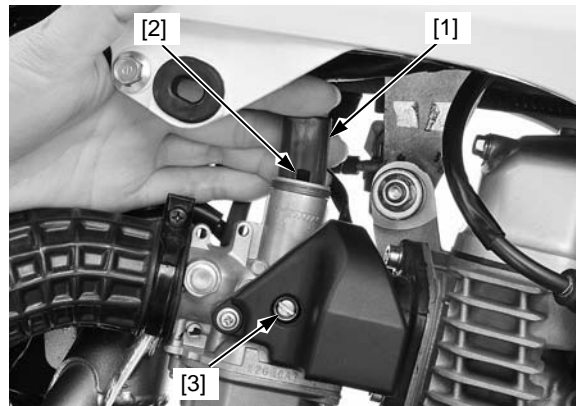

CARBURETOR HEATER (EXCEPT CO, III LA TYPES)

CARBURETOR HEATER REMOVAL/INSTALLATION

Remove the screw [1] and carburetor heater cover [2].

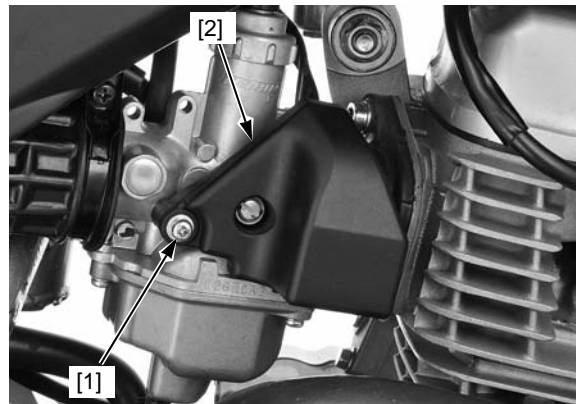

Disconnect the carburetor heater connector [1] and ground wire connector [2].

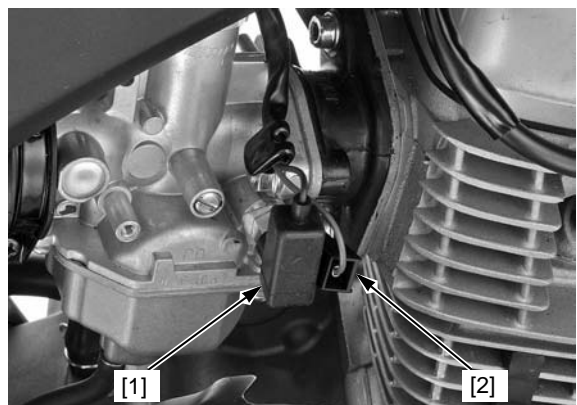

Remove the carburetor heater [1] and ground terminal [2].

Installation is in the reverse order of removal.

TORQUE: CARBURETOR HEATER:
4.9 N-m (0.5 kgf-m, 3.6 lbf-ft)

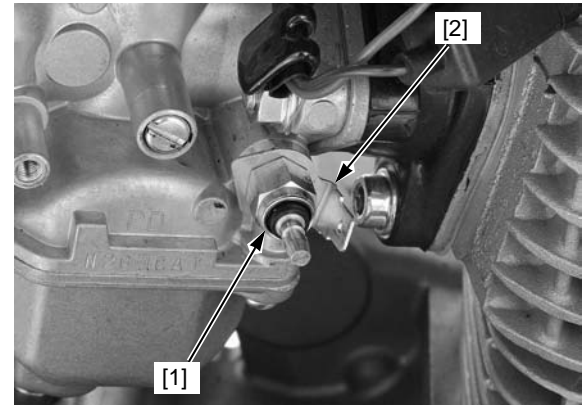

INSPECTION

Measure the resistance at the carburetor heater [1] terminals.

STANDARD: 8.2 – 12.3 Ω (25°C/77°F)

If the resistance is out of specification, replace the carburetor heater.

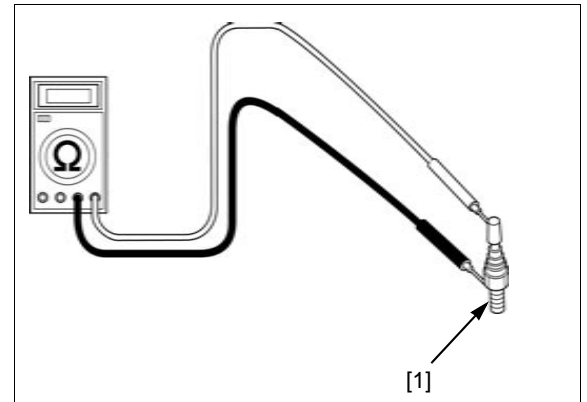

THERMO SWITCH INSPECTION

Remove the right side cover (page 2-2).

Remove the thermo switch from the connector boot [1].

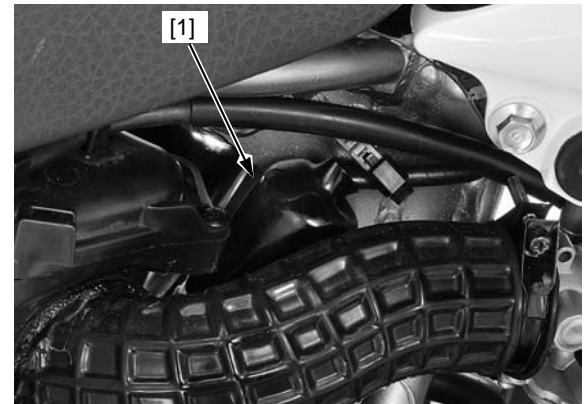

Disconnect the thermo switch 2P connector [1].

Check for continuity between the terminals.

STANDARD:
Above 20°C/68°F: No continuity
Below 7°C/45°F: Continuity

If thermo switch is out of specification, replace the switch.

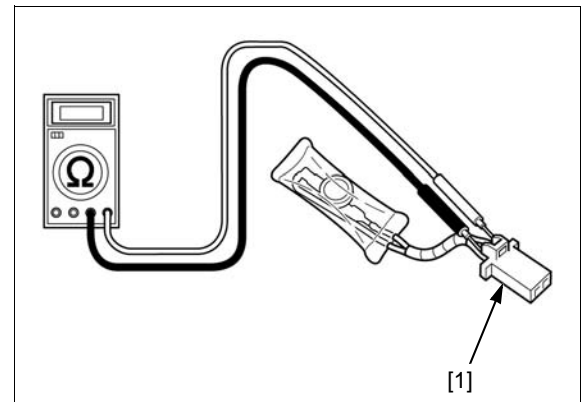

PILOT SCREW ADJUSTMENT

- The pilot screw are factory pre-set. Adjustment is not necessary unless the carburetor are overhauled or new pilot screw are installed.
- Use a tachometer with graduations of 50 min^{-1} (rpm) or smaller that will accurately indicate a 50 min^{-1} (rpm) change.

IDLE DROP PROCEDURE (XR125LK/LEK)

1. Turn the pilot screw clockwise until it is lightly seated then back it out the specification given.
This is an initial setting prior to the final pilot screw adjustment.
- Damage to the pilot screw seat will occur if the pilot screw is tightened to the seat.

INITIAL OPENING: 1-3/4 turns out

TOOL:

[1] Pilot screw wrench 07908-4730002

2. Warm up the engine to operating temperature. Stop and go riding for 10 minutes sufficient.
3. Stop the engine and connect a tachometer according to the tachometer manufacturer's instructions.
4. Disconnect the PAIR control valve vacuum hose [1], then connect the vacuum pump [2] and plug the vacuum port.

Apply the specified vacuum to the PAIR control valve vacuum hose more than 330 mm Hg.

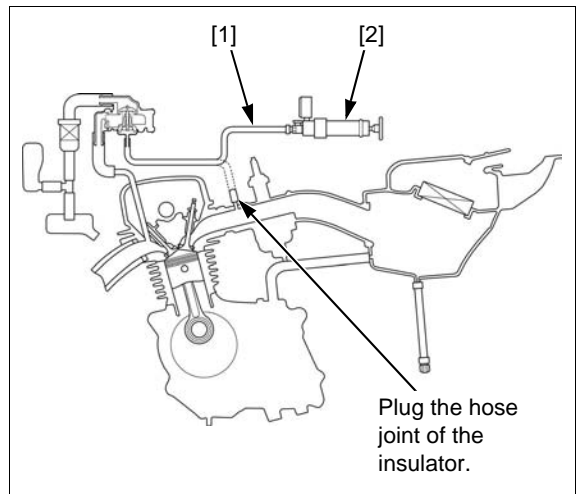
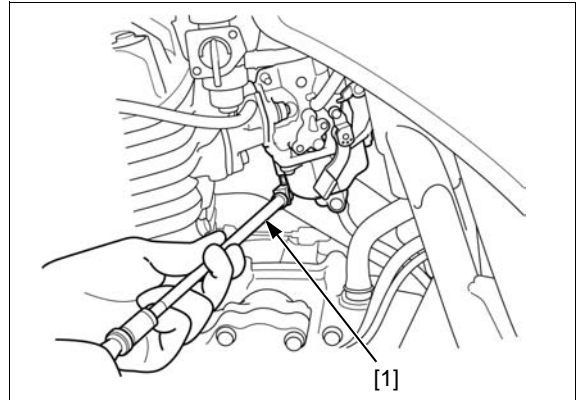

5. Start the engine and adjust the idle speed with the throttle stop screw [1].

IDLE SPEED: $1,500 \pm 100 \text{ min}^{-1}$ (rpm)

6. Turn the pilot screw inward or outward slowly to obtain the highest engine speed.
7. Lightly open the throttle 2 – 3 times, then adjust the idle speed with the throttle stop screw.
8. Turn the pilot screw inward to the final opening.

FINAL OPENING: 1 turns in from the position obtained in step 7

9. Readjust the idle speed with the throttle stop screw.

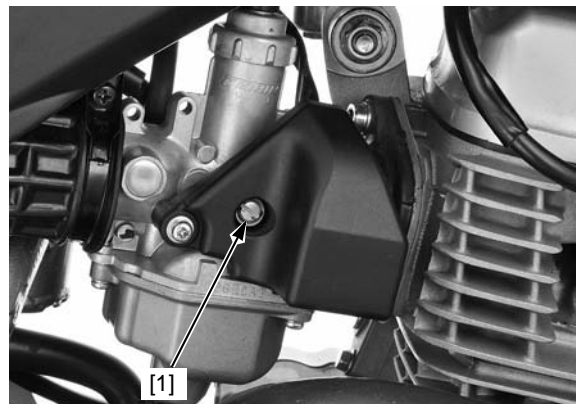

IDLE DROP PROCEDURE (XL125LK)

1. Turn the pilot screw clockwise until it is lightly seated then back it out the specification given.
This is an initial setting prior to the final pilot screw adjustment.

- Damage to the pilot screw seat will occur if the pilot screw is tightened to the seat.

INITIAL OPENING: 1-7/8 turns out

TOOL:

[1] Pilot screw wrench 07908-4730002

2. Warm up the engine to operating temperature.
Stop and go riding for 10 minutes sufficient.
3. Stop the engine and connect a tachometer according to the tachometer manufacturer's instructions.
4. Start the engine and adjust the idle speed with the throttle stop screw [1].

IDLE SPEED: 1,500 ± 100 min⁻¹ (rpm)

5. Turn the pilot screw inward or outward slowly to obtain the highest engine speed.
6. Lightly open the throttle 2 – 3 times, then adjust the idle speed with the throttle stop screw.
7. Turn the pilot screw inward to the final opening.

FINAL OPENING: 5/8 turns in from the position obtained in step 6

8. Readjust the idle speed with the throttle stop screw.

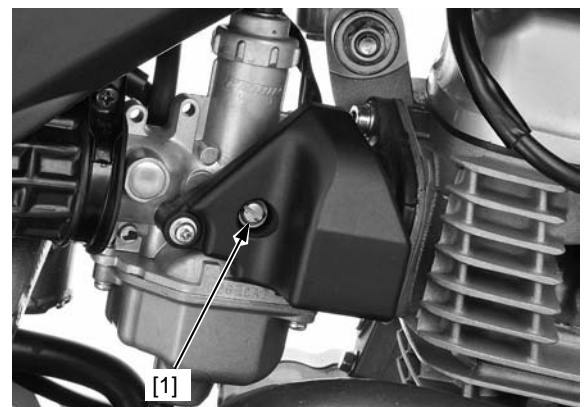
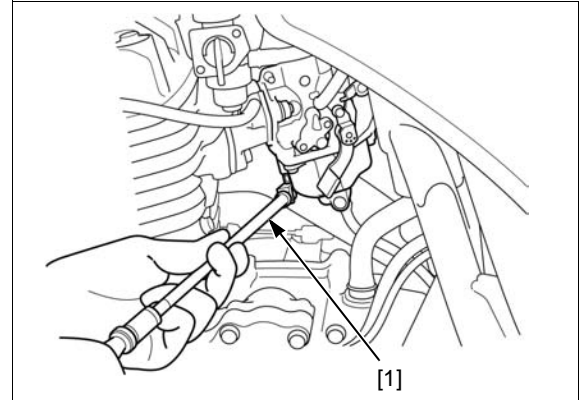

SECONDARY AIR SUPPLY SYSTEM (XR125LK/LEK)

SYSTEM INSPECTION

Start the engine and warm it up to normal operating temperature.

Remove the right side shroud (page 2-4).

Disconnect the air cleaner sub filter-to-PAIR control valve hose [1].

Check that the hose joint of the air filter is clean and free carbon deposits.

If the port is carbon fouled, check the PAIR check valve.

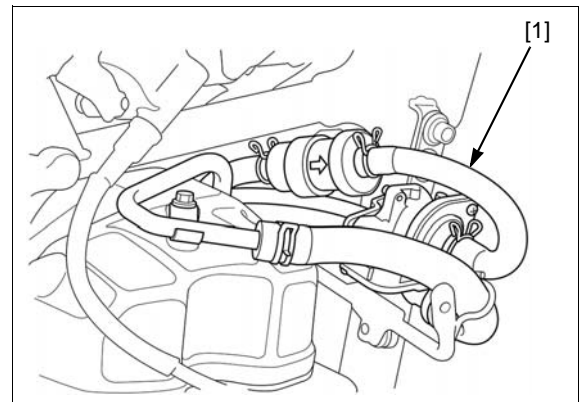

FUEL SYSTEM

Disconnect the PAIR control valve vacuum hose [1] from the insulator and plug it to keep air from entering. Connect the vacuum pump to the PAIR control valve.

TOOL:

[2] Vacuum pump **Commercially available**

Start the engine and open the throttle slightly to be certain that air is sucked in through the air cleaner sub filter-to-PAIR control valve hose [3].

If the air is not drawn in, check the air cleaner sub filter-to-PAIR control valve hose for clogging.

With the engine running, gradually apply vacuum to PAIR control valve.

Check that the air intake port stops drawing air, and that the vacuum does not bleed.

SPECIFIED VACUUM: 330 mm Hg

If the air drawn in, or if the specified vacuum is not maintained, install a new PAIR control valve.

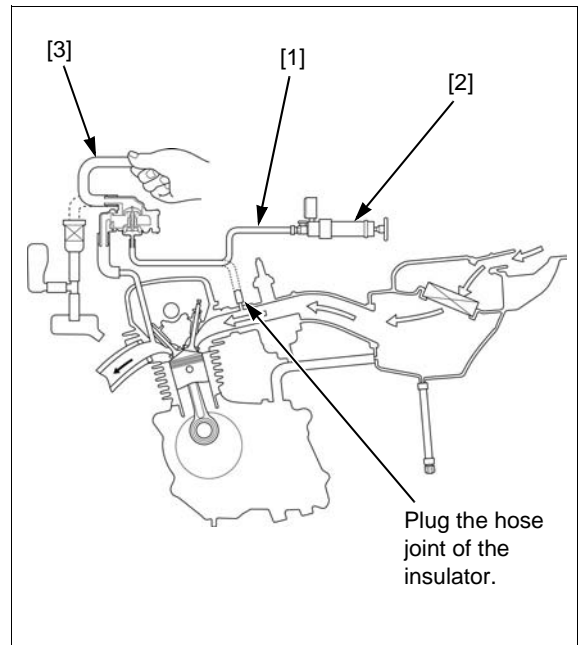

PAIR CHECK VALVE INSPECTION

Remove following:

- PAIR control valve (page 6-14)
- Two screws [1]
- Valve cover [2]
- PAIR check valve [3]

Check the valve reed for fatigue or damage, replace if necessary.

Replace the PAIR check valve if the seat rubber is cracked, deteriorated or damaged, or if there is clearance between the reed and stopper [4].

Installation is in the reverse order of removal.

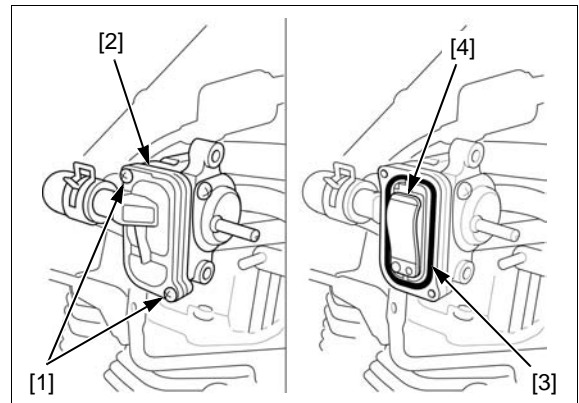

PAIR CONTROL VALVE REMOVAL/INSTALLATION

Remove the side shroud (page 2-4).

Disconnect the PAIR control valve vacuum hose [1].

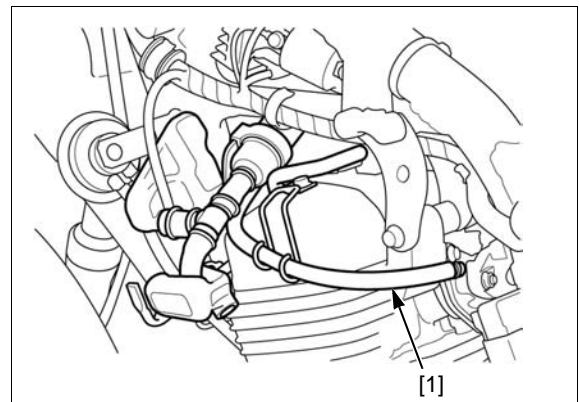

Disconnect the PAIR control valve-to-cylinder head cover hose [1] and sub air filter-to-PAIR control valve hose [2].
 Remove the nuts [3] and PAIR control valve [4].
 Installation is in the reverse order of removal.

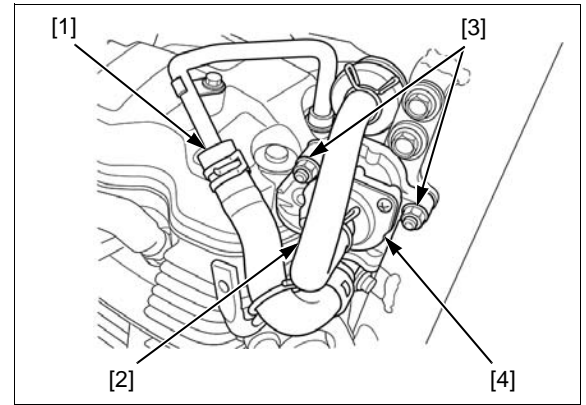

AIR SUCTION PIPE REMOVAL/INSTALLATION

Remove the PAIR control valve (page 6-14).
 Remove the bolts [1] and air suction pipe [2].
 Remove the O-ring [3] from the cylinder head cover.

Replace the O-ring with new one.

Installation is in the reverse order of removal.

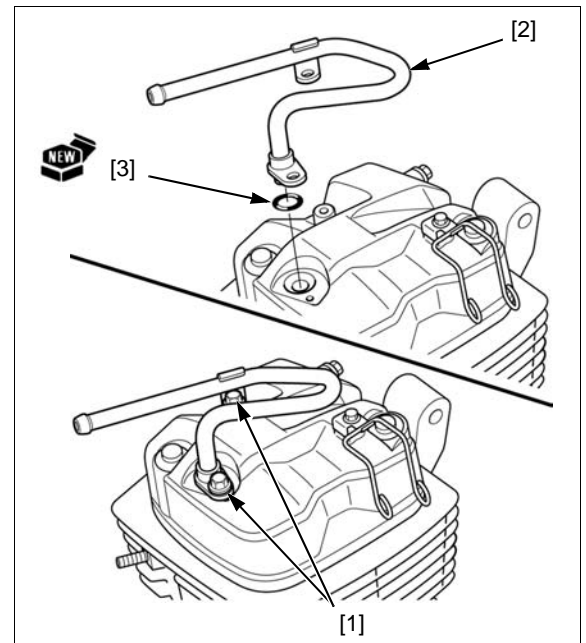

RESONATOR TANK AND AIR INLET COVER REMOVAL/INSTALLATION

Remove the side shroud (page 2-4).
 Disconnect the air inlet cover-to-three way joint hose [1].
 Remove the bolt [2] and air inlet cover [3].
 Disconnect resonator tank-to-three way joint hose [4].
 Remove the bolt [5] and resonator tank [6].
 Installation is in the reverse order of removal.

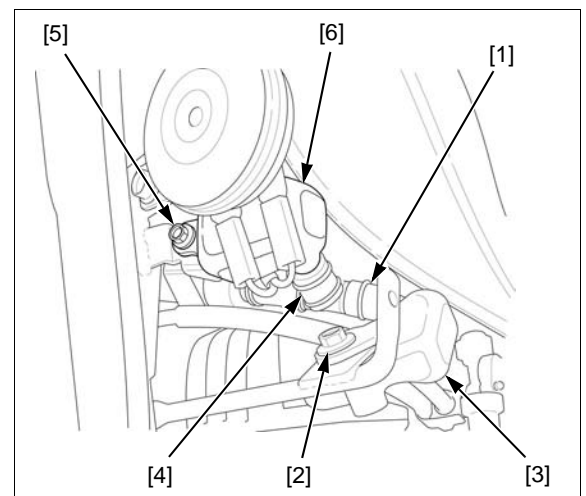

MEMO

7. LUBRICATION SYSTEM

LUBRICATION SYSTEM DIAGRAM	7-2	TROUBLESHOOTING	7-3
SERVICE INFORMATION	7-3	OIL PUMP	7-3

LUBRICATION SYSTEM DIAGRAM

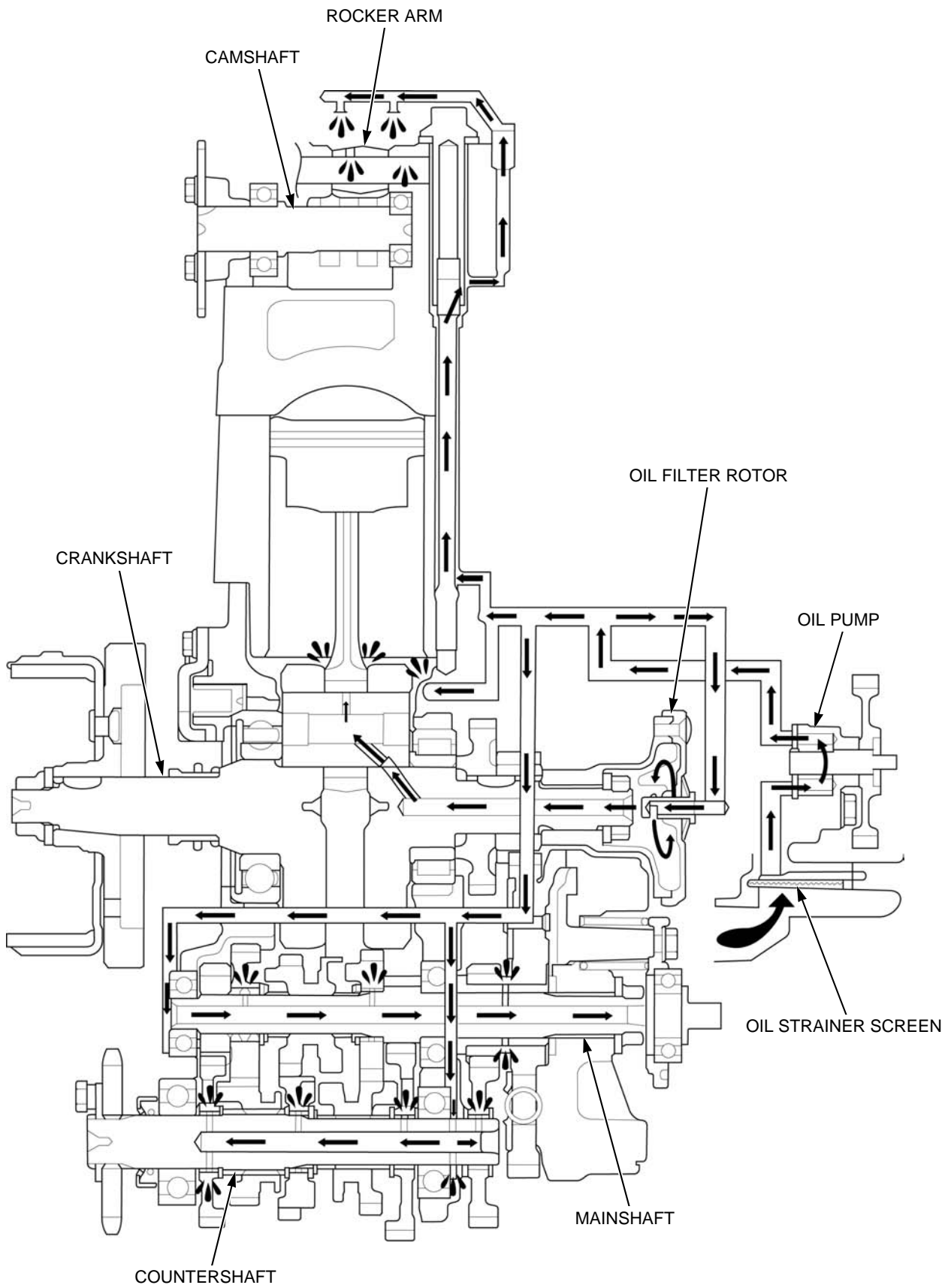

SERVICE INFORMATION

GENERAL

⚠ CAUTION

Used engine oil may cause skin cancer if repeatedly left in contact with the skin for prolonged periods. Although this is unlikely unless you handle used oil on a daily basis, it is still advisable to thoroughly wash your hands with soap and water as soon as possible after handling used oil.

- The oil pump can be serviced with the engine installed in the frame.
- When removing and installing the oil pump, use care not to allow dust or dirt to enter the engine.
- If any portion of the oil pump is worn beyond the specified service limit, replace the oil pump as an assembly.
- After the oil pump has been installed, check that there are no oil leaks and that oil pressure is correct.
- Engine oil level inspection (page 3-7)
- Engine oil change (page 3-7)
- Engine oil centrifugal filter cleaning (page 3-8)
- Engine oil strainer screen cleaning (page 3-7)

TROUBLESHOOTING

Engine oil level too low, high oil consumption

- External oil leaks
- Worn valve guide or stem seal
- Worn piston rings or incorrect piston ring installation
- Worn cylinder

Engine oil contamination

- Oil not changed often enough
- Clogged oil strainer
- Oil centrifugal filter not cleaned often enough
- Worn piston rings

OIL PUMP

REMOVAL

Remove the right crankcase cover (page 10-4).

Remove the oil pump driven gear [1].

Remove the two mounting bolts [2] and oil pump [3].

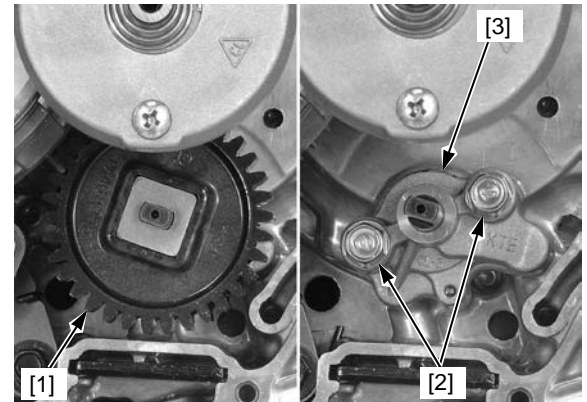

Remove the dowel pins [1] from the oil pump body.

INSTALLATION

Install the oil pump onto the right crankcase by aligning the dowel pins with the holes.

Install the removed parts in the reverse order of removal.

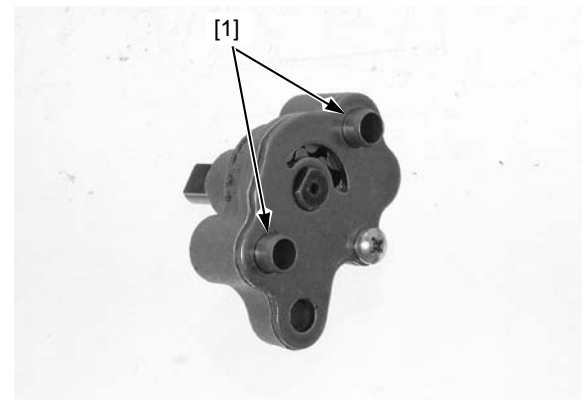

LUBRICATION SYSTEM

DISASSEMBLY/ASSEMBLY

Disassemble and assemble the oil pump as following illustration.

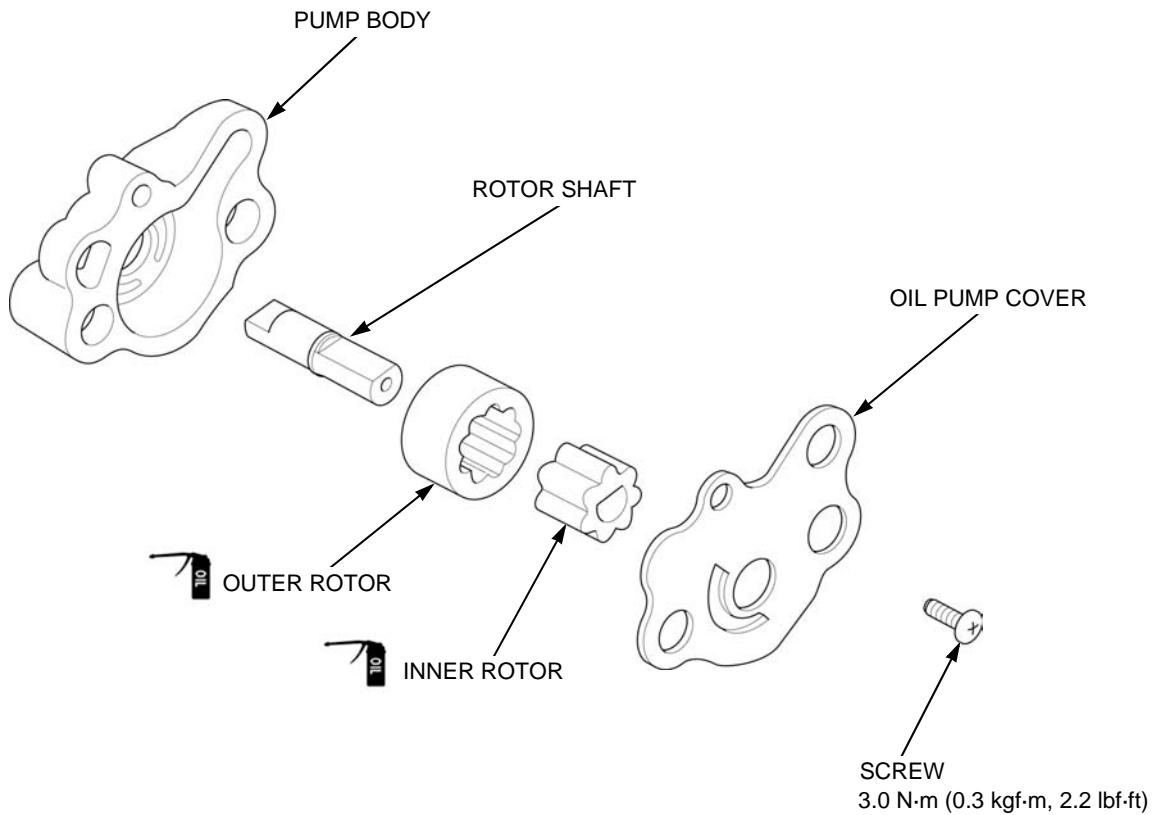

INSPECTION

Disassemble the oil pump (page 7-4).

- Measure at several places and use the largest reading to compare to the service limit.
- If any portion of the oil pump is worn beyond the specified service limit, replace the oil pump and pump cover as an assembly.

Temporarily install the outer rotor, inner rotor and oil pump shaft into the oil pump body.

TIP CLEARANCE

Measure the tip clearance.

SERVICE LIMIT: 0.20 mm (0.008 in)

BODY CLEARANCE

Measure the body clearance.

SERVICE LIMIT: 0.25 mm (0.010 in)

SIDE CLEARANCE

Remove the oil pump shaft.

Measure the side clearance using a straight edge and feeler gauge.

SERVICE LIMIT: 0.12 mm (0.005 in)

Assemble the oil pump (page 7-4).

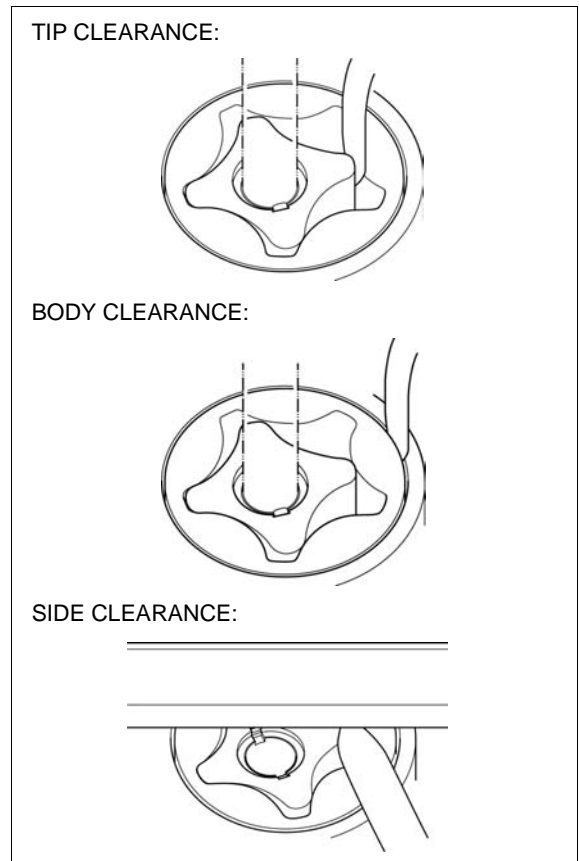

8. CYLINDER HEAD/VALVES

SYSTEM COMPONENTS.....	8-2	CAMSHAFT.....	8-5
SERVICE INFORMATION.....	8-2	CAMSHAFT HOLDER	8-8
TROUBLESHOOTING.....	8-3	CYLINDER HEAD	8-11
CYLINDER COMPRESSION.....	8-3	CAM CHAIN TENSIONER LIFTER.....	8-17
CYLINDER HEAD COVER.....	8-4		

CYLINDER HEAD/VALVES

SYSTEM COMPONENTS

XR125LK/LEK shown:

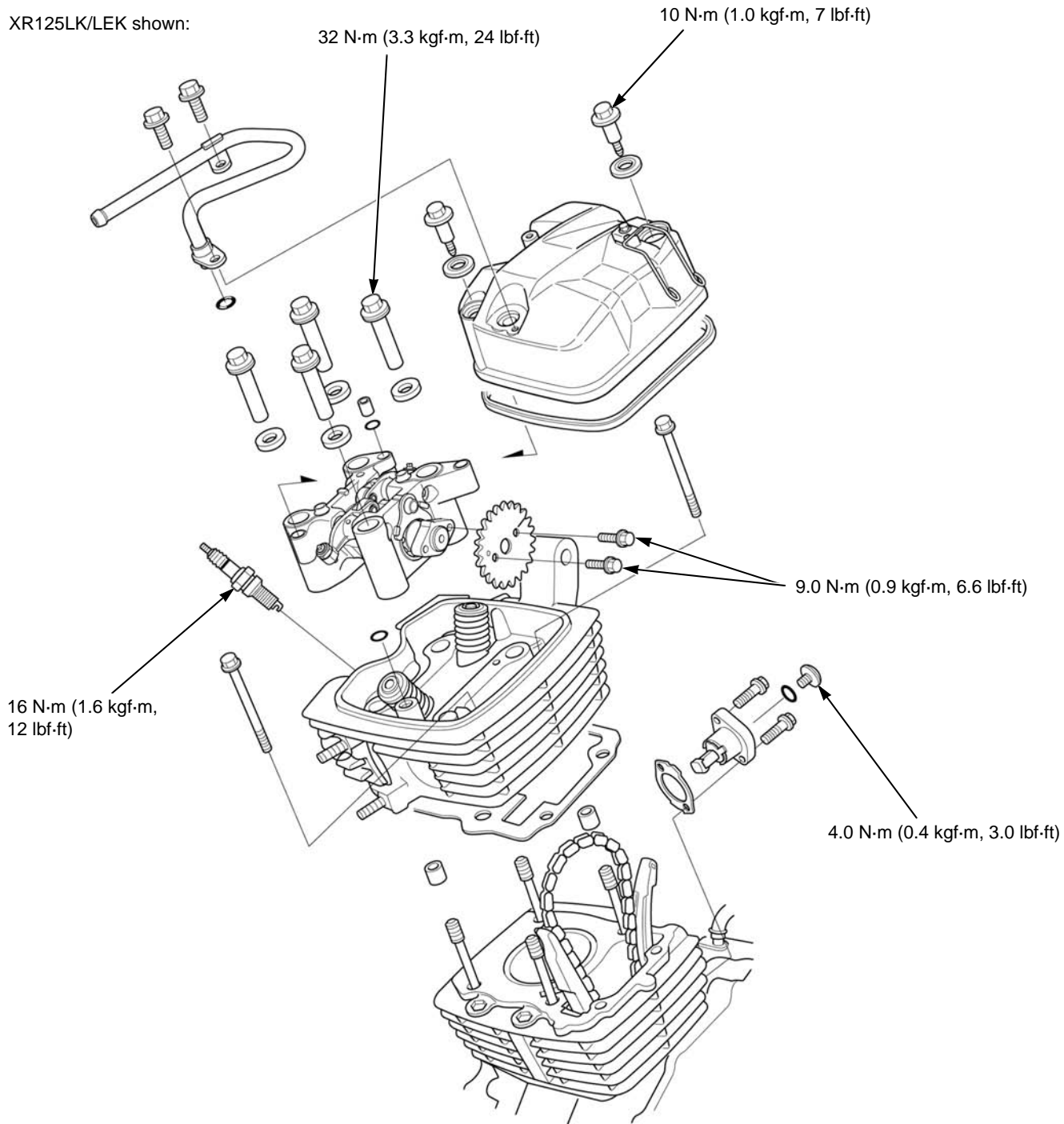

SERVICE INFORMATION

GENERAL

- This section covers service of the cylinder head, valves, rocker arms and camshaft.
- The camshaft can be serviced with the engine installed in the frame.
- The cylinder head service requires engine removal.
- Be careful not to damage the mating surfaces when removing the cylinder head cover and cylinder head. Do not strike the cylinder head cover and cylinder head too hard during removal.
- When disassembling, mark and store the disassembled parts to ensure that they are reinstalled in their original locations.
- Clean all disassembled parts with cleaning solvent and dry them by blowing them off with compressed air before inspection.
- Camshaft and rocker arm lubricating oil is fed through oil passages in the cylinder head and camshaft holder. Clean the oil passages before assembling cylinder head.

TROUBLESHOOTING

- Engine top-end problems usually affect engine performance. These problems can be diagnosed by a compression test, or by tracing top-end noise with a sounding rod or stethoscope.
- If the performance is poor at low speeds, check for white smoke in the crankcase breather hose. If the hose is smoky, check for a seized piston ring.

Compression too low, hard starting or poor performance at low speed

- Valves
 - Incorrect valve clearance
 - Burned or bent valve
 - Incorrect valve timing
 - Weak valve spring
 - Uneven valve seating
 - Valve stuck open
- Cylinder head
 - Leaking or damaged cylinder head gasket
 - Warped or cracked cylinder head
 - Loose spark plug
- Cylinder/piston problem.

Compression too high

- Excessive carbon build-up on piston head or combustion chamber

Excessive smoke

- Worn valve stem or valve guide
- Damaged stem seal
- Cylinder/piston problem (page 9-3)

Excessive noise

- Incorrect valve clearance
- Sticking valve or broken valve spring
- Excessive worn valve seat
- Worn or damaged camshaft
- Worn rocker arm and/or shaft
- Worn rocker arm and valve stem end
- Worn cam sprocket teeth or cam chain
- Worn or damaged cam chain tensioner
- Cylinder/piston problem (page 9-3)

Rough idle

- Low cylinder compression

CYLINDER COMPRESSION

Warm up the engine to normal operating temperature. Stop the engine and remove the spark plug.

Install the compression gauge [1] into the spark plug hole.

Shift the transmission into neutral.

Open the throttle all the way and crank the engine with the starter motor or kickstarter until the gauge reading stops rising. The maximum reading is usually reached within 4 – 7 seconds.

COMPRESSION PRESSURE:

1,275 kPa (13.0 kgf/cm², 185 psi) at 300 min⁻¹ (rpm)

If compression is high, it indicates that carbon deposits have accumulated on the combustion chamber and/or the piston crown.

If compression is low, pour 3 – 5 cm³ (0.1 – 0.2 oz) of engine oil into the cylinder through the spark plug hole and recheck the compression.

If the compression increases from the previous value, check the cylinder, piston and piston rings.

- Leaking cylinder head gasket
- Worn cylinder, piston or piston ring

If compression is the same as the previous value, check the valves for leakage.

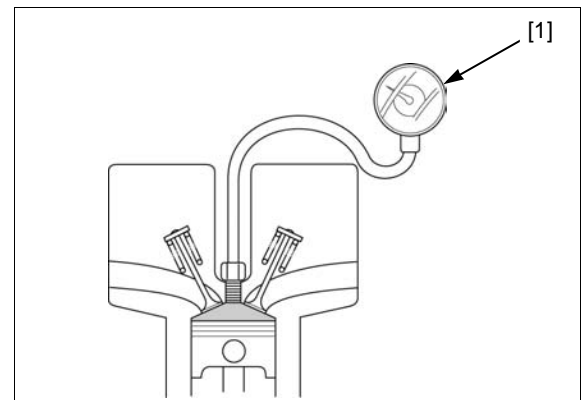

CYLINDER HEAD COVER

REMOVAL/INSTALLATION

Remove the following (XR125LK/LEK only):

- PAIR control valve (page 6-14)
- Air suction pipe (page 6-15)

Remove the side shrouds (page 2-4).

Remove the cylinder head cover special bolts [1], mounting rubbers [2] and cylinder head cover [3].

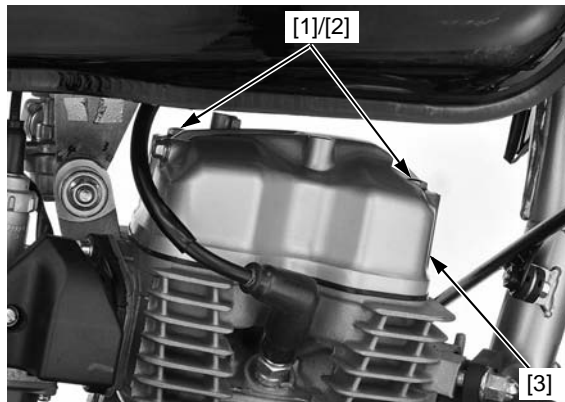

Remove the gasket [1] from the cylinder head cover [2].

XR125LK/LEK: Remove the O-ring [3].

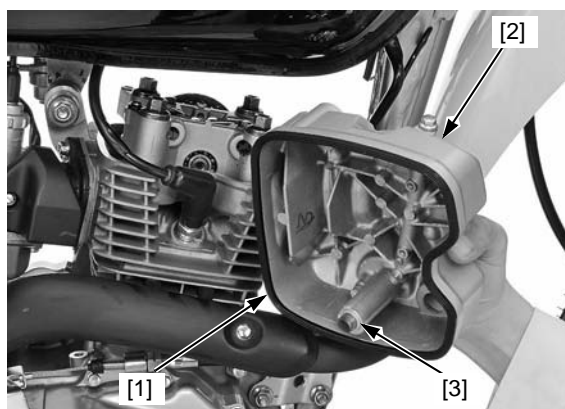

Remove the dowel pin [1] and O-ring [2] from the camshaft holder.

Clean the oil passage and air passage of the cylinder head cover using compressed air.

Install the dowel pin into the camshaft holder.

Coat a new O-ring with engine oil and install it onto the dowel pin.

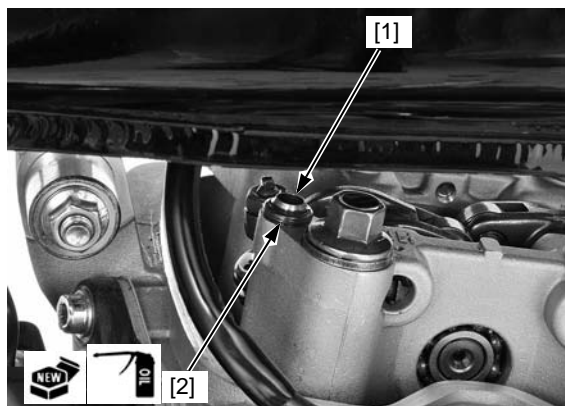

Install a new gasket [1] into the cylinder head cover groove.

XR125LK/LEK: Coat a new O-ring [2] with engine oil and install it onto the dowel pin.

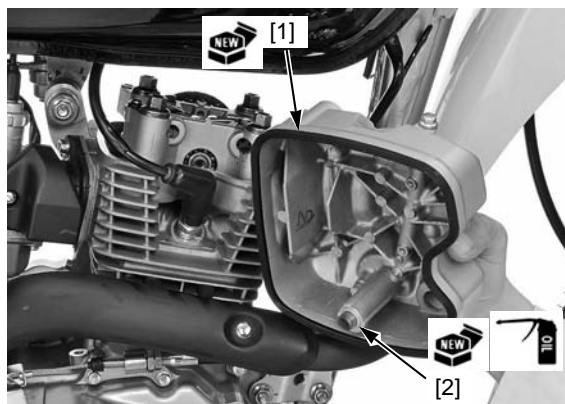

Install the cylinder head cover [1] onto the cylinder head.

Install the mounting rubbers onto the cylinder head cover with their "UP" marks [4] facing up.

Install the cylinder head cover bolts [2] with the mounting rubbers [3].

Tighten the cylinder head cover bolts to the specified torque.

TORQUE: 10 N·m (1.0 kgf·m, 7 lbf·ft)

Install the removed parts in the reverse order of removal.

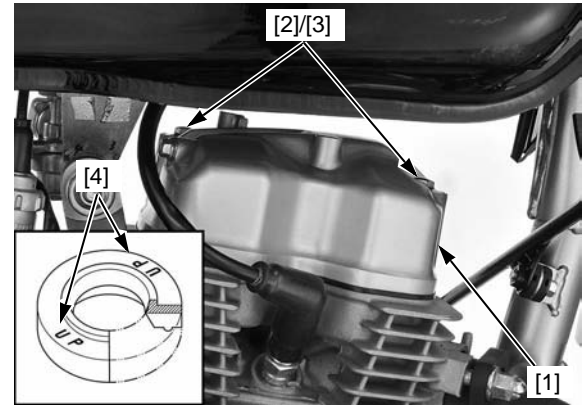

CAMSHAFT

REMOVAL

Remove the cylinder head cover (page 8-4).

Remove the timing hole cap [1] and crankshaft hole cap [2].

Remove the O-rings [3] from the caps.

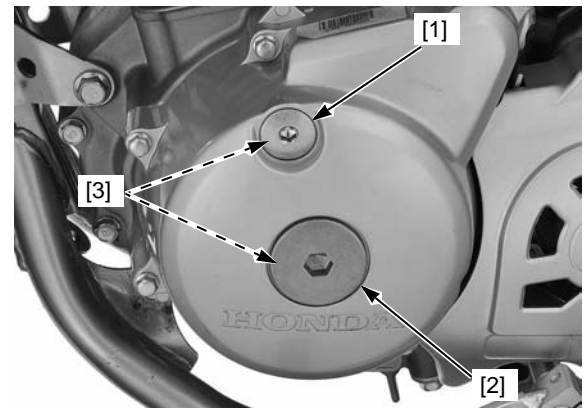

Rotate the crankshaft counterclockwise and align the "T" mark [1] on the flywheel with the index notch [2] on the left crankcase cover.

Make sure the piston is at TDC (Top Dead Center) on the compression stroke.

This position can be confirmed by checking for slack in the rocker arms.

If there is no slack, rotate the crankshaft counterclockwise one full turn and align the "T" mark with the index notch again.

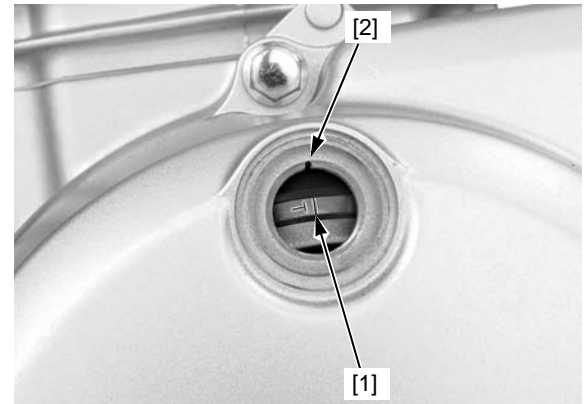

Remove the sealing plug and O-ring from the cam chain tensioner lifter.

Turn the cam chain tensioner lifter shaft clockwise fully and secure it using the special tool.

TOOL:

[1] Tensioner stopper 070MG-0010100

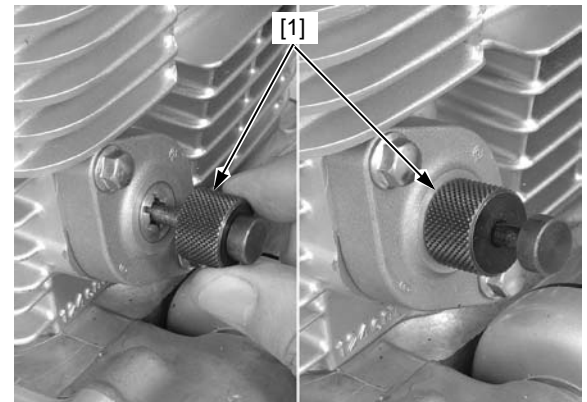

CYLINDER HEAD/VALVES

Be careful not to let the sprocket bolts fall into the crankcase. Remove the cam sprocket bolts [1]. Remove the cam sprocket [2] off the camshaft flange and cam chain [3]. Attach a piece of wire to the cam chain to prevent it from falling into the crankcase.

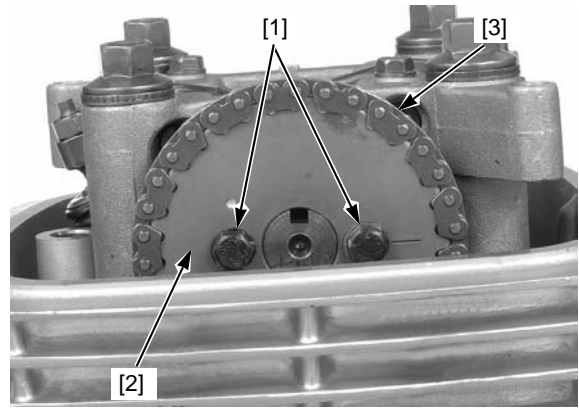

Be careful not to let the bolt and plate fall into the crankcase. Remove the bolt [1] and camshaft retainer plate [2]. Remove the camshaft [3] from the camshaft holder.

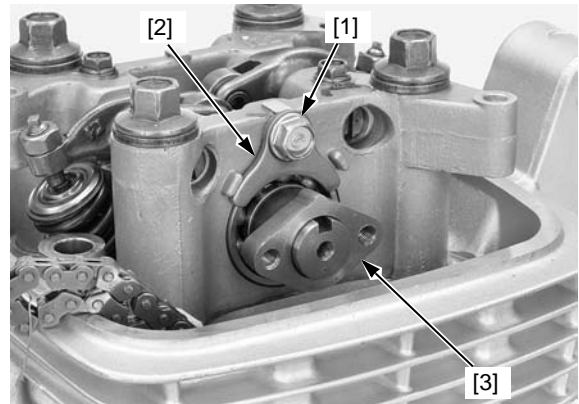

INSPECTION

Turn the outer race of each camshaft bearing [1] with your finger. The bearings should turn smoothly and quietly.

Also check that the bearing inner race fits tightly on the camshaft.

Replace the camshaft assembly if the bearing does not turn smoothly, quietly, or if they fit loosely on the camshaft.

Measure the height of each cam lobe.

SERVICE LIMITS: IN: 32.96 mm (1.298 in)
EX: 32.85 mm (1.293 in)

Inspect the cam lobes for damage or excessive wear. Check the rocker arm if each cam lobe are worn or damaged.

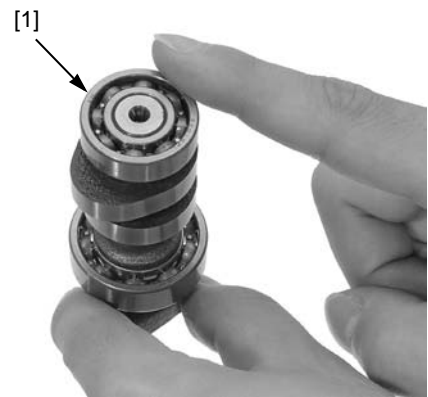

INSTALLATION

Lubricate the camshaft bearings with engine oil. Apply molybdenum oil solution to the cam lobes.

Install the camshaft [1] with its tab [2] facing up.

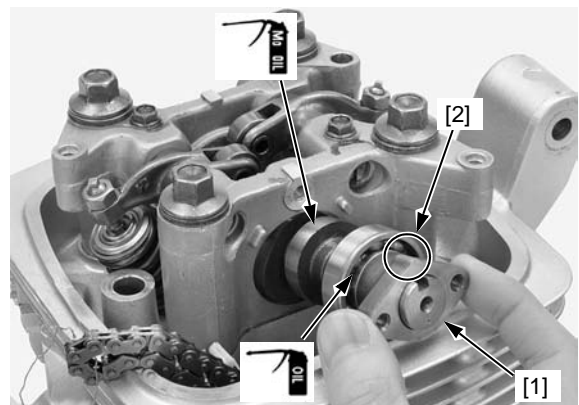

Instal retainer plate [1] and bolt [2], then tighten the bolt securely.

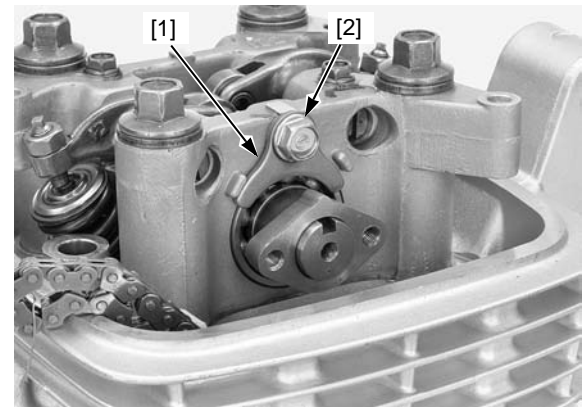

Be careful not to jam the cam chain.

Rotate the crankshaft counterclockwise and align the "T" mark [1] on the flywheel with the index notch [2] on the left crankcase cover.

Make sure the piston is at TDC (Top Dead Center).

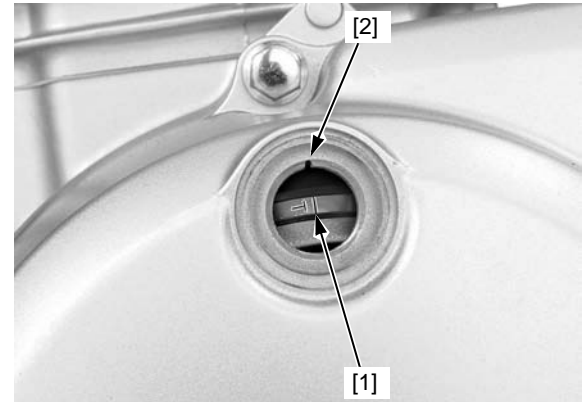

Apply engine oil to the cam chain [1].

Install the cam sprocket [2] onto the cam chain so that the index line [3] aligns with the upper surface of the cylinder head.

Install the cam sprocket onto the camshaft flange.

Tighten the "o" mark [5] side bolt first.

Install the cam sprocket bolts [4] and tighten them.

TORQUE: 9.0 N·m (0.9 kgf·m, 6.6 lbf·ft)

Remove the tensioner stopper from the cam chain tensioner lifter.

Turn the crankshaft counterclockwise one full turn (360°).

Be sure that the index line on the cam sprocket aligns with the upper surface of the cylinder head when the "T" mark on the flywheel is aligned with the index notch on the crankcase cover.

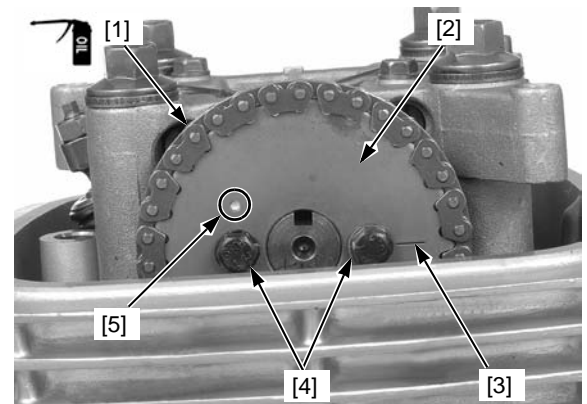

Coat a new O-ring [1] with engine oil and install it into the tensioner lifter groove.

Install the plug [2] and tighten it.

TORQUE: 4.0 N·m (0.4 kgf·m, 3.0 lbf·ft)

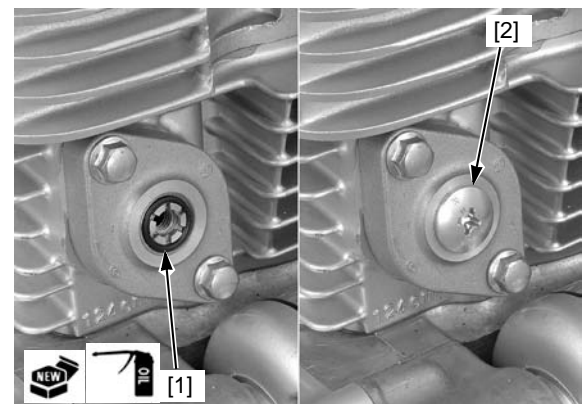

CYLINDER HEAD/VALVES

Coat new O-rings [1] with engine oil and install them onto the timing hole cap [2] and crankshaft hole cap [3]. Apply grease to the crankshaft hole cap threads. Install the crankshaft hole cap and tighten it.

TORQUE: 15 N·m (1.5 kgf·m, 11 lbf·ft)

Install the timing hole cap and tighten it.

TORQUE: 10 N·m (1.0 kgf·m, 7 lbf·ft)

Install the cylinder head cover (page 8-4)

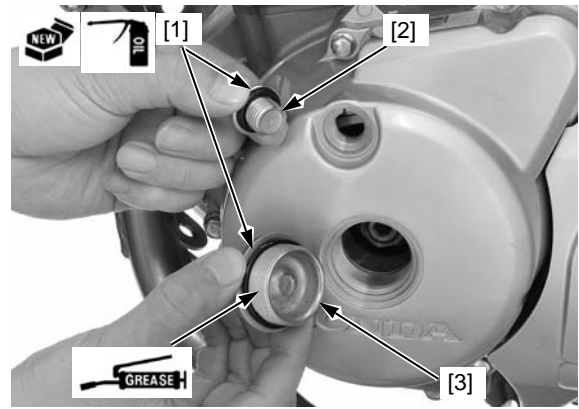

CAMSHAFT HOLDER

REMOVAL

Remove the cam sprocket (page 8-5).

Loosen the cylinder head bolts [1]. Remove the camshaft holder nuts [2], washers [3] and the camshaft holder [4].

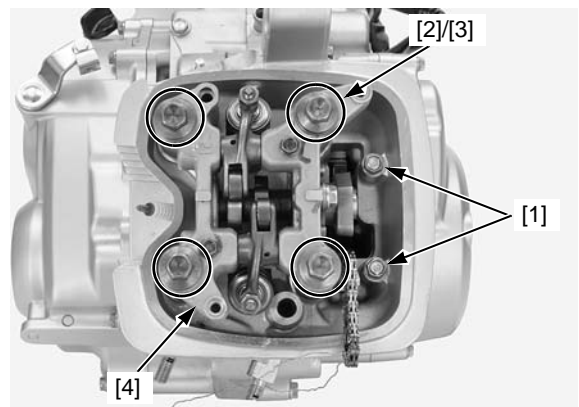

DISASSEMBLY

Remove the bolt [1] and camshaft retainer plate [2]. Remove the camshaft [3] from the camshaft holder.

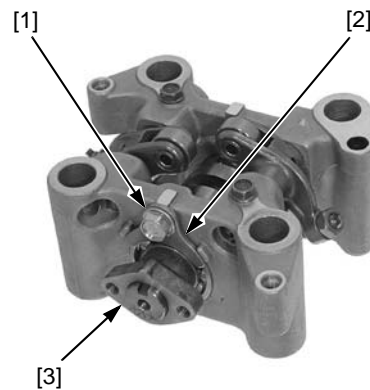

Remove the rocker arm shaft bolts [1].

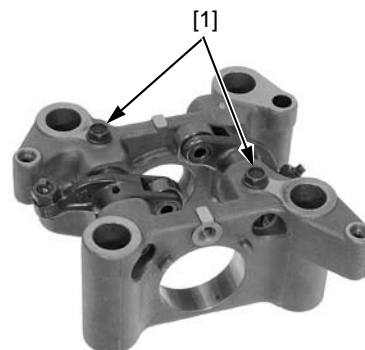

Remove the rocker arm shafts [1] and rocker arms [2] from the holder.

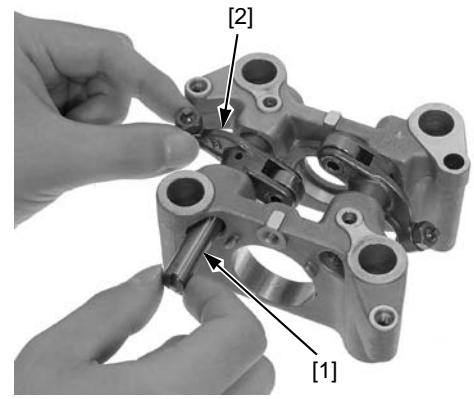

ASSEMBLY

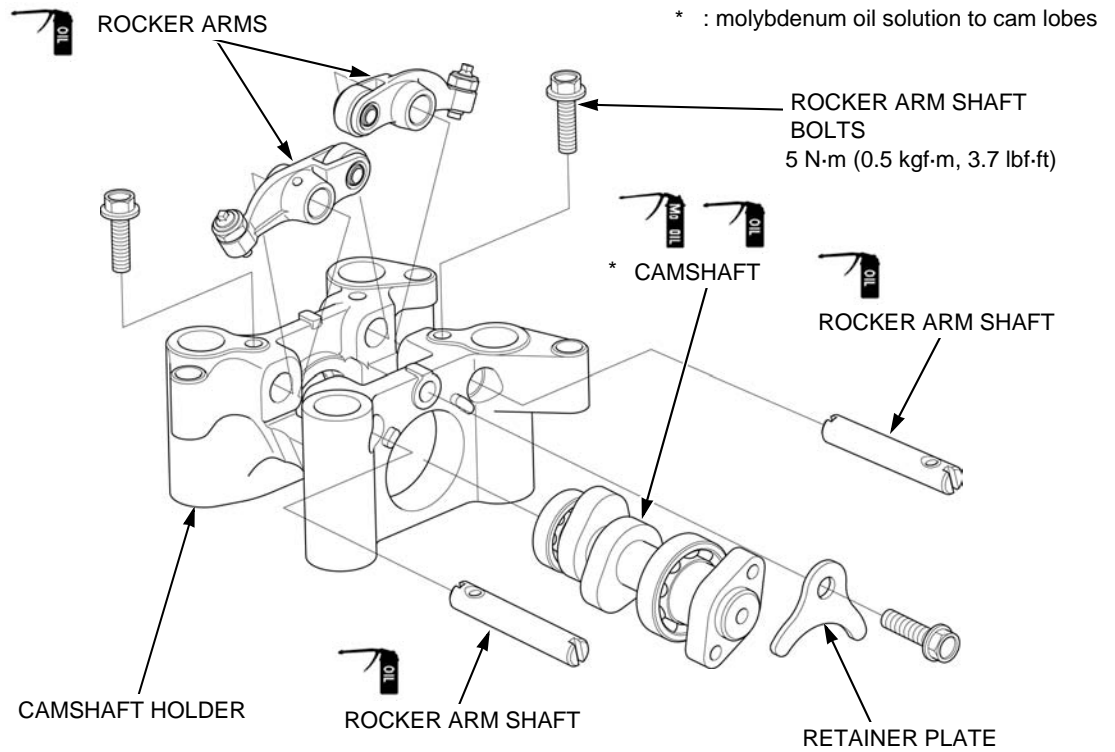

Apply engine oil to the rocker arm [1] inner surfaces, rollers and rocker arm shaft [2] entire surfaces.

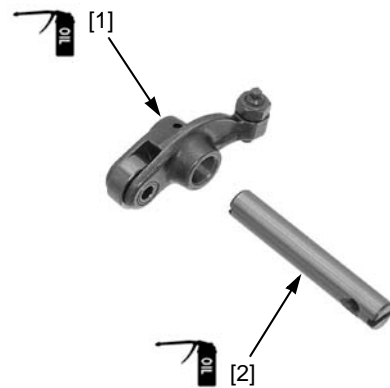

CYLINDER HEAD/VALVES

Note the directions of the bolt holes in the rocker arm shafts. Set the rocker arms [1] in the camshaft holder, then install the rocker arm shafts [2] into the camshaft holder through the rocker arms.

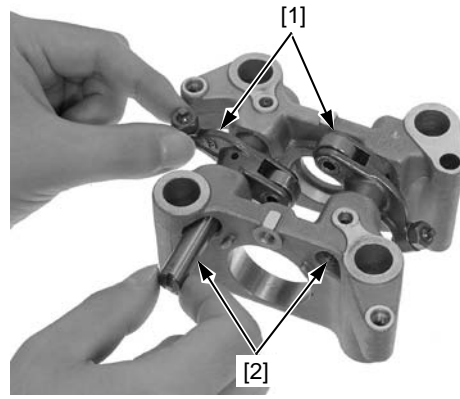

Align the bolt holes in the camshaft holder and rocker arm shafts [1] using a screwdriver, and install the rocker arm shaft bolts [2].

Tighten the rocker arm shaft bolts.

TORQUE: 5.0 N-m (0.5 kgf-m, 3.7 lbf-ft)

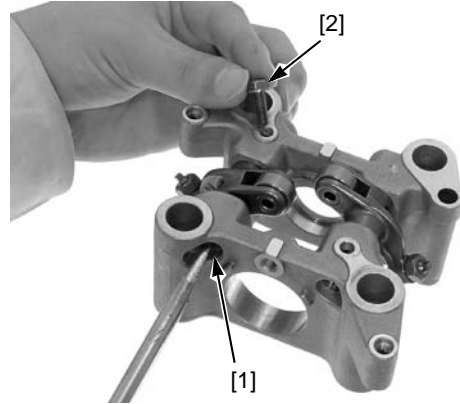

Lubricate the camshaft bearings [1] with engine oil. Apply molybdenum oil solution to the cam lobes [2].

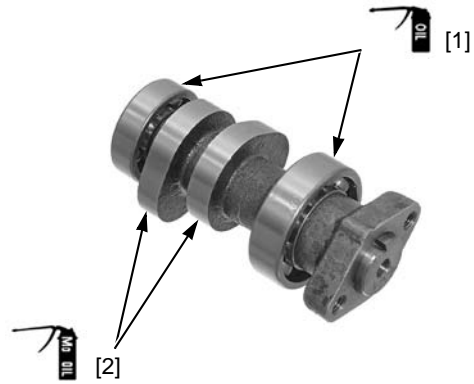

Install the camshaft [1] into the camshaft holder with its tab [2] facing up.

Install the camshaft retainer plate [3] and bolt [4], then tighten the bolt securely.

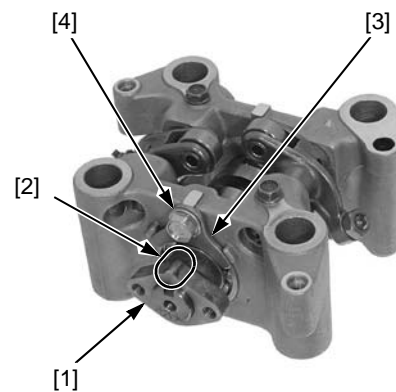

INSTALLATION

Install the camshaft holder [1] onto the cylinder head by aligning the pins [2] with the holes [3].

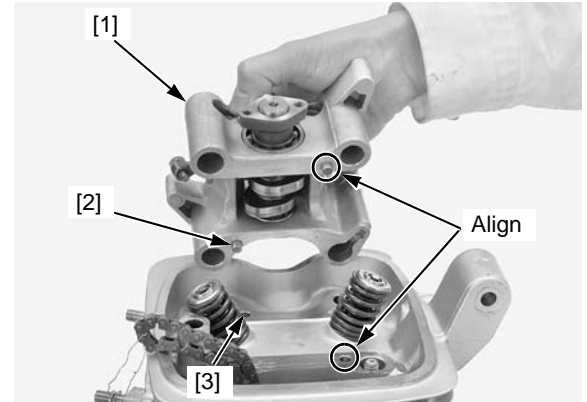

Apply engine oil to the threads and seating surfaces of the camshaft holder special nuts [1]. Install the washers [2] and camshaft holder special nuts, then tighten the nuts to the specified torque.

TORQUE: 32 N·m (3.3 kgf·m, 24 lbf·ft)

Tighten the cylinder head bolts [3].

Install the cam sprocket (page 8-6).

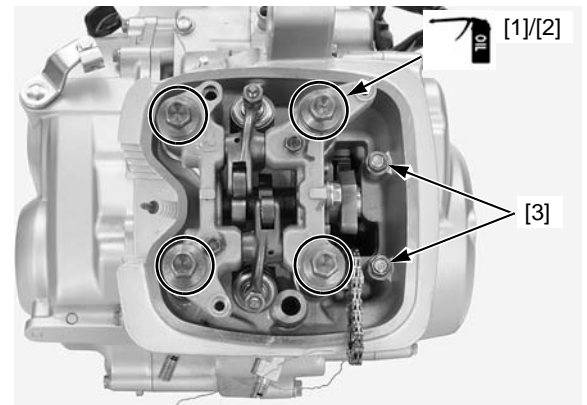

CYLINDER HEAD

REMOVAL/INSTALLATION

Remove the following:

- Engine (page 13-3)
- Camshaft holder (page 8-8)
- Spark plug [1]
- Two cylinder head bolts [2] and cylinder head [3].

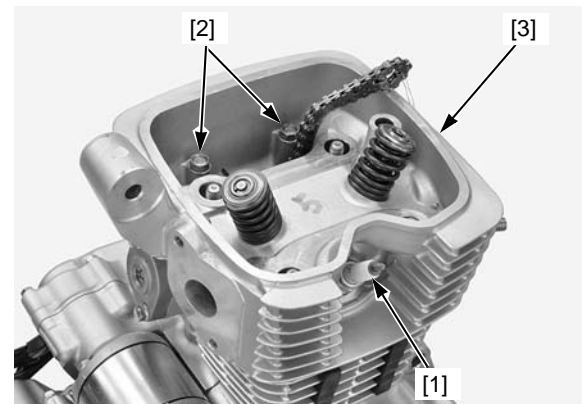

Remove the cylinder head gasket [1] and two dowel pins [2].

Be careful not to damage the mating surfaces.

Clean the mating surfaces of the cylinder head and cylinder.

Install the dowel pins and a new gasket.

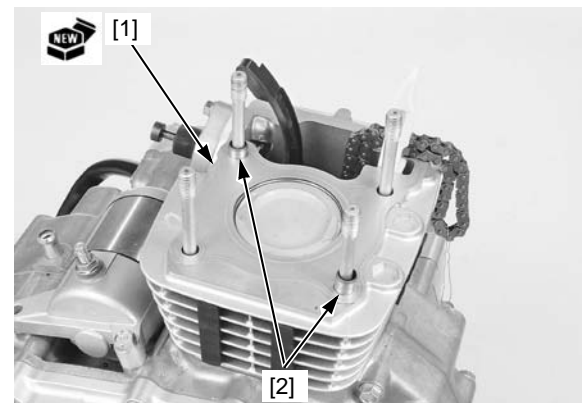

CYLINDER HEAD/VALVES

Route the cam chain [1] through the cylinder head and install the cylinder head [2] onto the cylinder.

Loosely install the cylinder head bolts [3].

Install the spark plug [4] and tighten it.

TORQUE: 16 N·m (1.6 kgf·m, 12 lbf·ft)

Install the following:

- Camshaft holder (page 8-11).
- Engine (page 13-5)

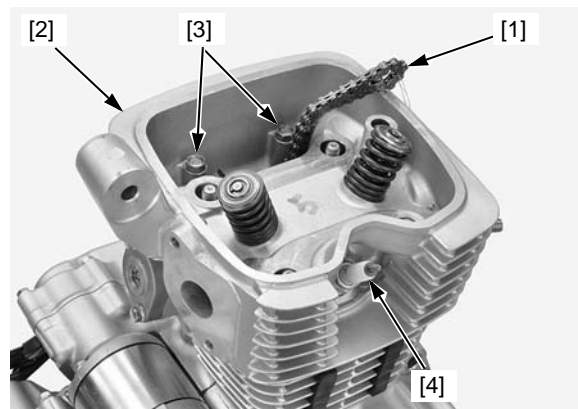

DISASSEMBLY

To prevent loss of tension, do not compress the valve spring more than necessary to remove the cotters.

While compressing the valve spring with a valve spring compressor, remove the valve cotters [1].

TOOL:

[2] Valve spring compressor 07757-0010000

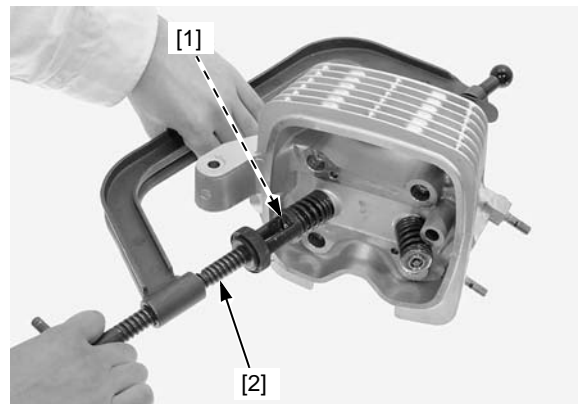

Mark all disassembled parts to ensure correct reassembly.

Remove the following:

- Spring retainers [1]
- Inner and outer valve springs [2]
- Intake and exhaust valves [3]
- Stem seals [4]
- Spring seats [5]

Remove the carbon deposits from the combustion chamber.

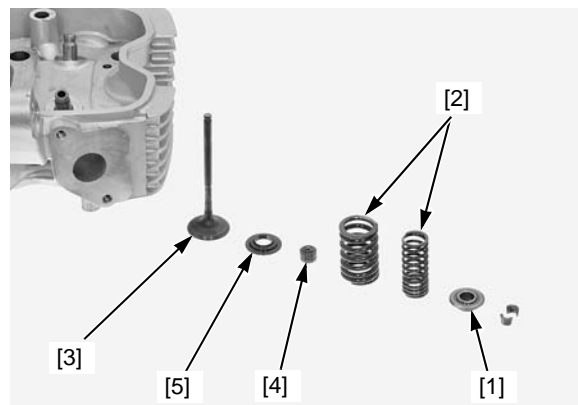

ASSEMBLY

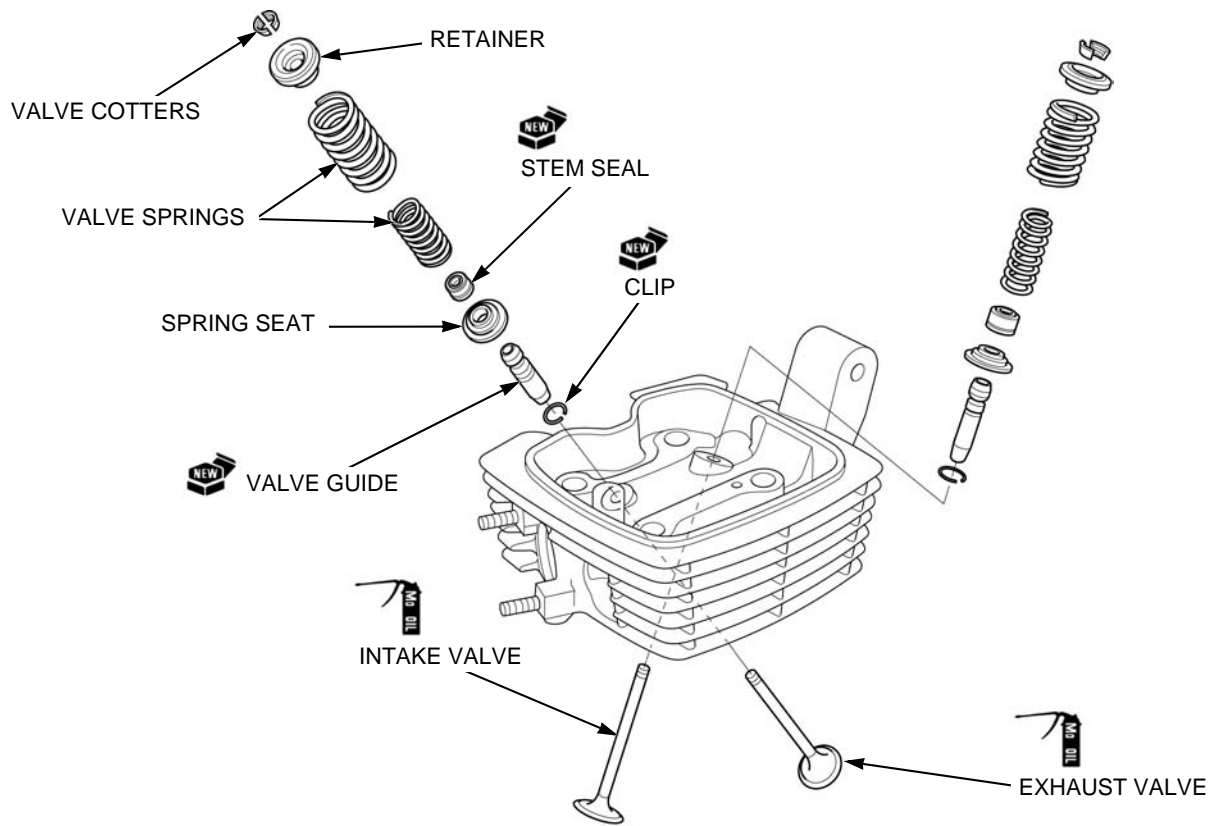

Clean the cylinder head assembly with solvent and blow through all oil passage with compressed air.

Install the spring seats [1] and new valve stem seals [2].

Lubricate each valve stem with molybdenum oil solution.

To avoid damage to the seal, turn the valve slowly when inserting.

Insert the intake and exhaust valves [3] into the valve guides.

Install the inner and outer valve springs [4] with the tightly wound coils facing the combustion chamber.

Install the spring retainers [5].

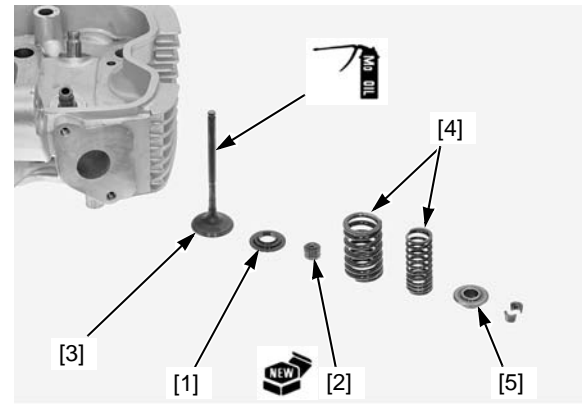

Combustion chamber side

CYLINDER HEAD/VALVES

Compress the valve spring and install the valve cotters [1].

TOOL:

[2] Valve spring compressor 07757-0010000

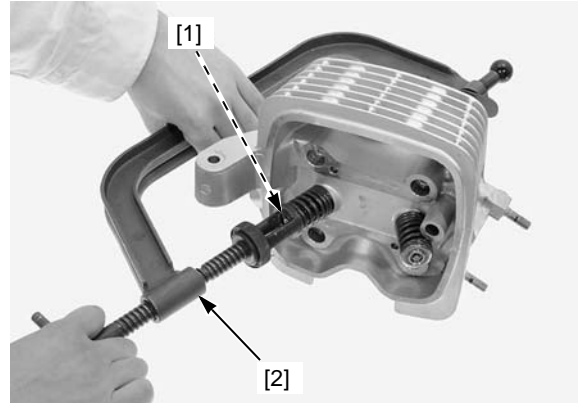

Support the cylinder head above the work bench surface to prevent valve damage. Tap the stems [1] gently with a bar and hammer to firmly seat the cotters.

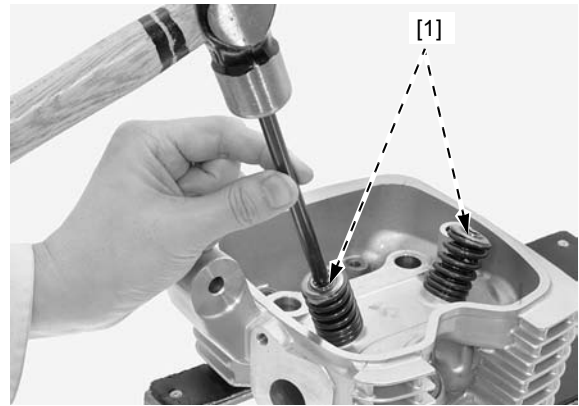

INSPECTION

Take care not to tilt or lean the reamer in the guide while reaming. Ream the valve guide to remove the carbon build-up before checking the valve guide. Insert the reamer from the combustion chamber side of the cylinder head and always rotate the reamer clockwise.

TOOL:

[1] Valve guide reamer 07984-MA60001

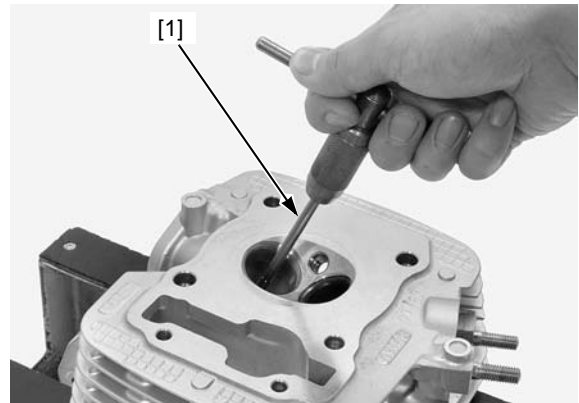

Measure each valve guide I.D. and record it.

SERVICE LIMIT: IN/EX: 5.04 mm (0.198 in)

Calculate the stem-to-guide clearance.

**SERVICE LIMITS: IN: 0.07 mm (0.003 in)
EX: 0.09 mm (0.004 in)**

If the stem-to-guide clearance exceeds the service limit, determine if a new guide with standard dimensions would bring the clearance within tolerance. If so replace the guides as necessary and ream to fit.

If the stem-to-guide clearance still exceeds the service limit with a new guide, replace the valve and guide.

Inspect and reface the valve seat whenever new valve guides are installed.



VALVE GUIDE REPLACEMENT

Chill the replacement valve guides in the freezer section of a refrigerator for about an hour.

Wear insulated gloves to avoid burns when handling the heated cylinder head. Using a torch to heat the cylinder head may cause warping.

Heat the cylinder head to 130°C – 140°C (275°F – 290°F) with a hot plate or oven. Do not heat the cylinder head beyond 150°C (300°F). Use temperature indicator sticks, available from welding supply stores, to be sure the cylinder head is heated to the proper temperature.

Support the cylinder head and drive the valve guides and clips out of the cylinder head from the combustion chamber side.

TOOL:
[1] Valve guide driver 07942-8920000

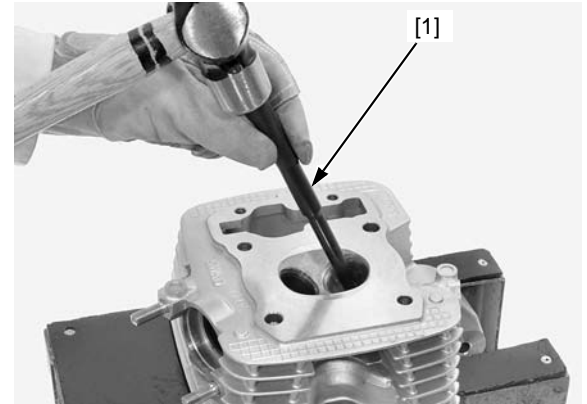

While the cylinder head is still heated, take off the new valve guides [1] from the freezer and install new clips [2] to the new guides. Drive new guides in the cylinder head from the camshaft side.

TOOL:
[3] Valve guide driver 07942-8920000

Let the cylinder head cool to room temperature.

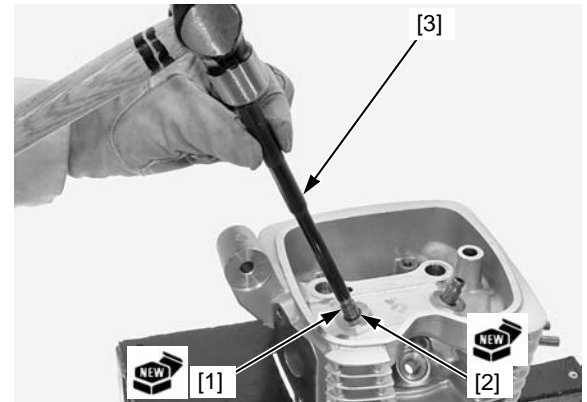

Take care not to tilt or lean the reamer in the guide while reaming. Use cutting oil on the reamer during this operation.

Ream the new valve guides. Insert the reamer from the combustion chamber side of the cylinder head and always rotate the reamer clockwise.

TOOL:
[1] Valve guide reamer 07984-MA60001

Clean the cylinder head thoroughly to remove any metal particles after reaming, and inspect and reface the valve seats (page 8-16).

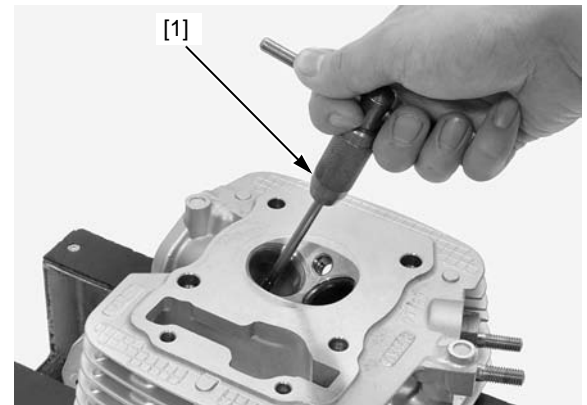

VALVE SEAT INSPECTION

Clean the intake and exhaust valves thoroughly to remove the carbon deposits.

Apply light coating of Prussian Blue to the valve seats. Tap the valve against the valve seat several times without rotating the valve, using a rubber hose or other hand lapping tool [1].

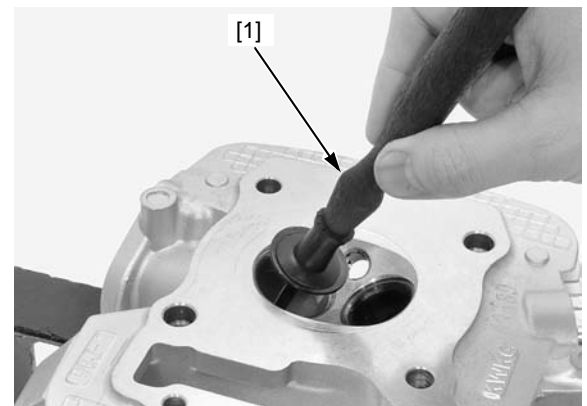

CYLINDER HEAD/VALVES

The valve cannot be grounded. If the valve face is burned or badly worn or if it contacts the seat unevenly, replace the valve.

Remove the valve and inspect the width of each valve seat.

The valve seat contact should be within the specified width and even all around the circumference.

STANDARD: 0.9 – 1.1 mm (0.035 – 0.043 in)
SERVICE LIMIT: 1.5 mm (0.06 in)

If the valve seat width is not within specification, reface the valve seat.

Inspect the valve seat face for:

- Damaged face:
 - Replace the valve and reface the valve seat.
- Uneven seat width:
 - Bent or collapsed valve stem;
 - Replace the valve and reface the valve seat.
- Contact area (too high or too low area)
 - Reface the valve seat.

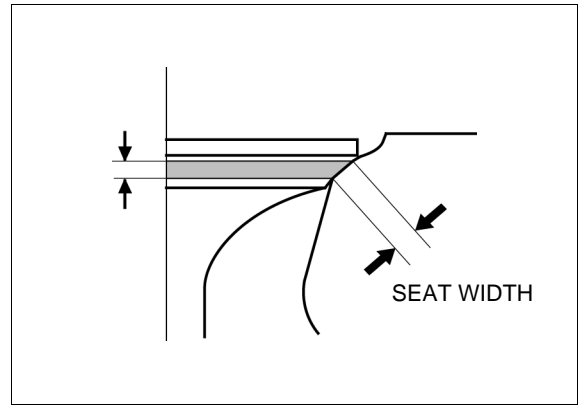

VALVE SEAT REFACING

Follow the refacing manufacturer's operating instructions.

Valve Seat Cutters, a grinder or equivalent valve seat refacing equipment are recommended to correct a worn valve seat.

TOOLS:

Seat cutter, 27.5 mm (45° IN)	07780-0010200
Seat cutter, 24.5 mm (45° EX)	07780-0010100
Flat cutter, 28 mm (32° IN)	07780-0012100
Flat cutter, 25 mm (32° EX)	07780-0012000
Interior cutter, 30 mm (60° IN)	07780-0014000
Interior cutter, 22 mm (60° EX)	07780-0014202
Cutter holder	07781-0010400

Using 45 degree cutter and cut the seat to the proper width.

Make sure that all pitting and irregularities are removed.

Refinish if necessary.

STANDARD SEAT WIDTH:

0.9 – 1.1 mm (0.035 – 0.043 in)

Excessive lapping pressure may deform or damage the seat.

Lapping compound can cause damage if it enters between the valve stem and guide.

After cutting the seat, apply lapping compound to the valve face and lap the valve using light pressure. Change the angle of lapping tool [1] frequently to prevent uneven seat wear.

After lapping, wash any residual compound off the cylinder head and valve.

Recheck the seat contact after lapping.

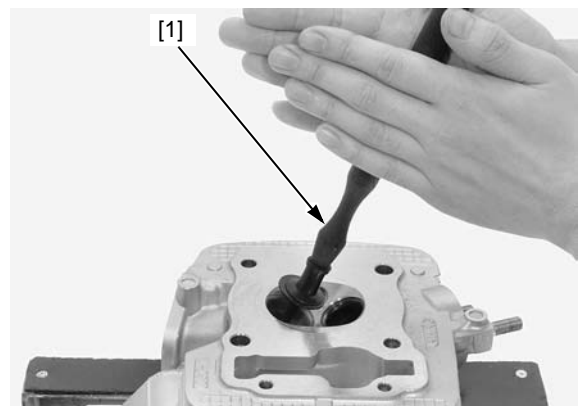
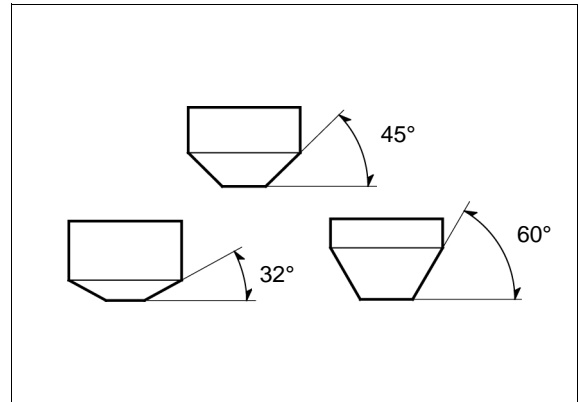

CAM CHAIN TENSIONER LIFTER

REMOVAL/INSTALLATION

Remove the sealing plug [1] and O-ring [2] from the cam chain tensioner lifter.

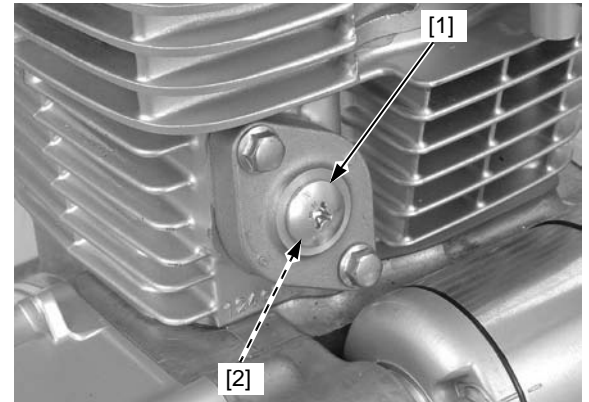

Turn the cam chain tensioner lifter shaft [1] clockwise fully and secure it using the special tool.

TOOL:

[2] Tensioner stopper 070MG-0010100

Remove the two mounting bolts [3].

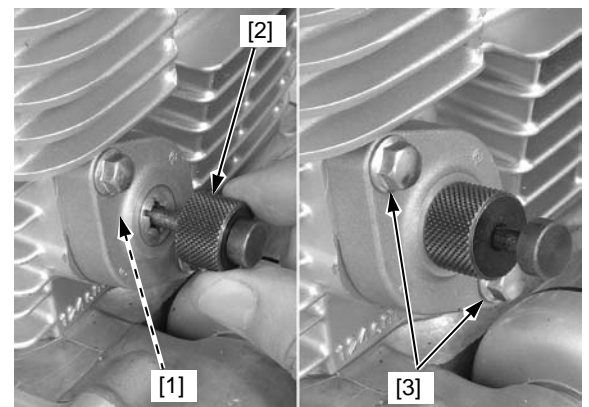

Remove the cam chain tensioner lifter [1] and gasket [2] from the cylinder.

Remove the tensioner stopper from the tensioner lifter.

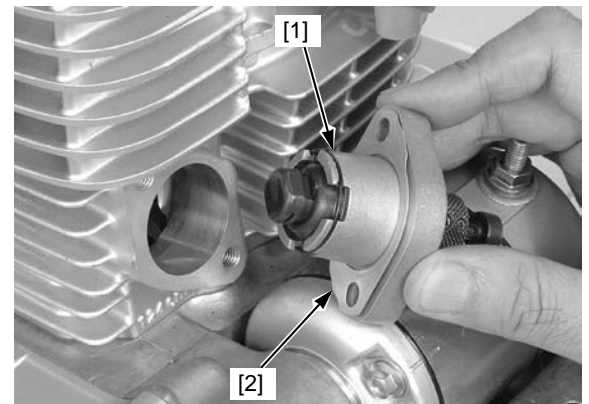

Check the cam chain tensioner lifter operation:

- The tensioner lifter shaft should not go into the body when it is pushed.
- When it is turned clockwise with a screwdriver, the tensioner lifter shaft should be pulled into the body. The shaft should spring out of the body as soon as the screwdriver is released.

Turn the cam chain tensioner lifter shaft clockwise fully and secure it using the special tool.

TOOL:

[1] Tensioner stopper 070MG-0010100

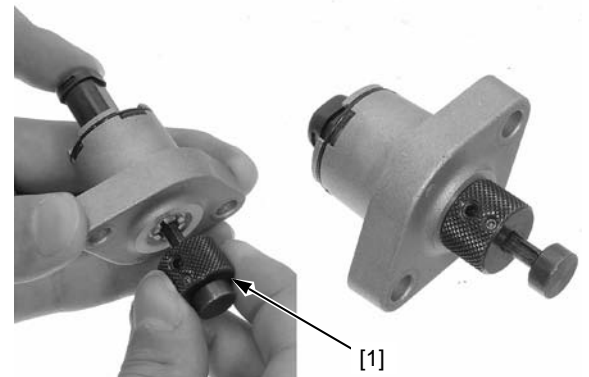

CYLINDER HEAD/VALVES

Install a new gasket [1] and cam chain tensioner lifter [2] onto the cylinder.

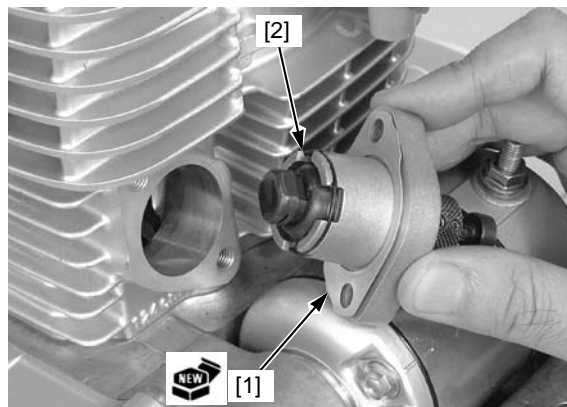

Install the two mounting bolts [1] and tighten them.

Remove the tensioner stopper from the tensioner lifter.

Coat a new O-ring [2] with engine oil and install it into the tensioner lifter groove.

Install the plug [3] and tighten it.

TORQUE: 4.0 N·m (0.4 kgf·m, 3.0 lbf·ft)

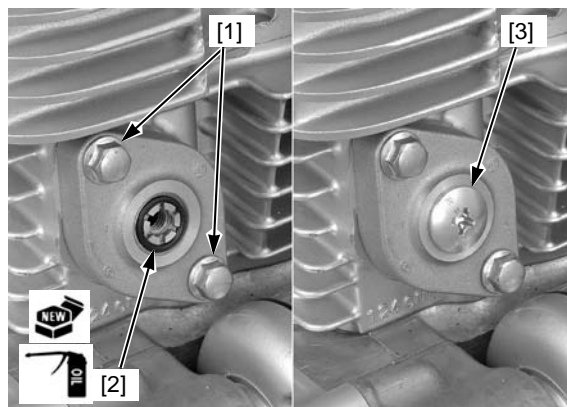

9. CYLINDER/PISTON

SYSTEM COMPONENTS.....	9-2	CYLINDER	9-4
SERVICE INFORMATION	9-3	PISTON	9-5
TROUBLESHOOTING.....	9-3		

SYSTEM COMPONENTS

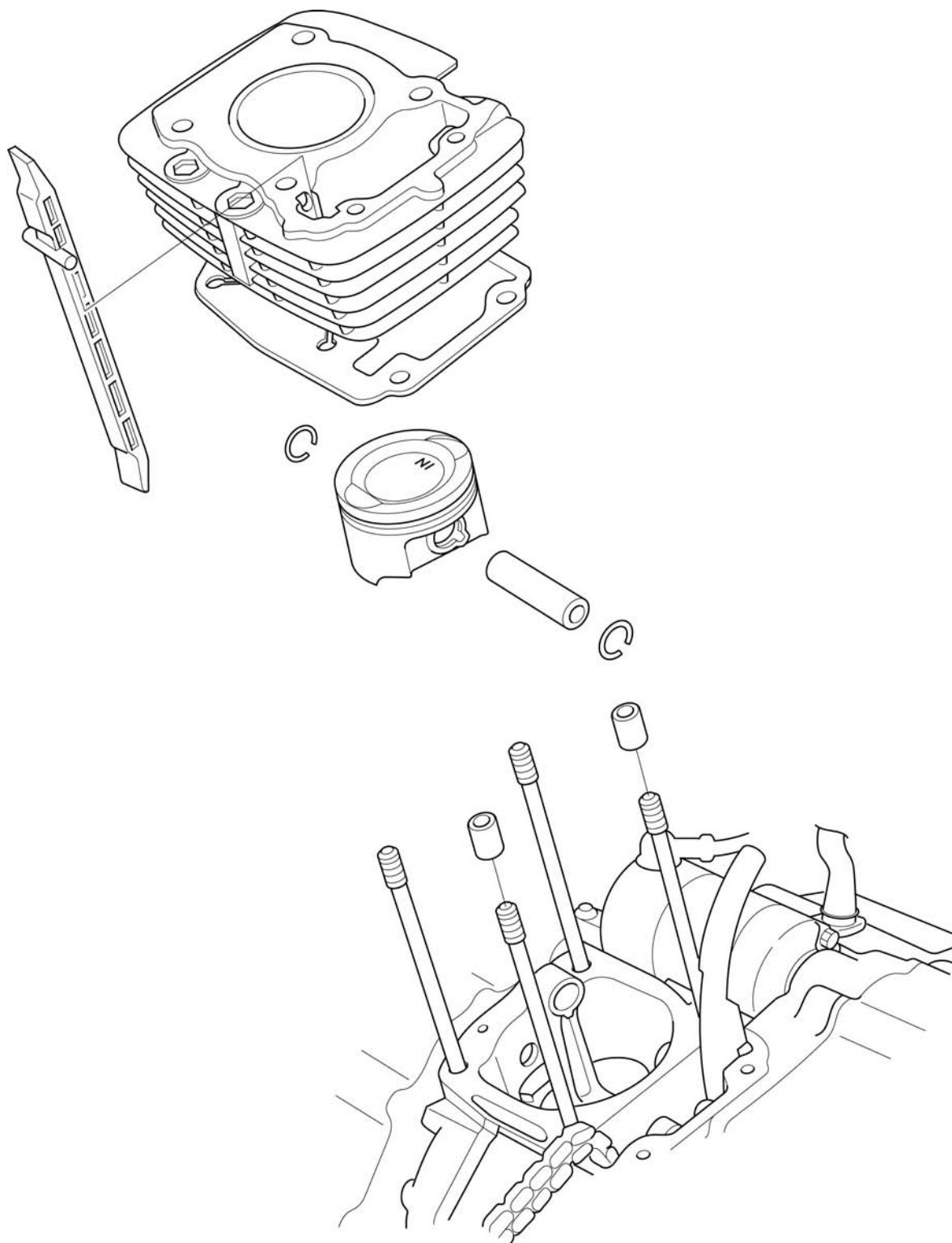

SERVICE INFORMATION

GENERAL

- The cylinder and piston services require engine removal.
- Take care not to damage the cylinder wall and piston.
- Be careful not to damage the mating surfaces when removing the cylinder. Do not strike the cylinder too hard during removal.
- Camshaft and rocker arm lubricating oil is fed through an oil passage in the cylinder. Clean the oil passage before installing cylinder.

TROUBLESHOOTING

Compression too low, hard starting or poor performance at low speed

- Leaking cylinder head gasket
- Worn, stuck or broken piston ring
- Worn or damaged cylinder and piston

Compression too high, overheating or knocking

- Excessive carbon built-up on piston or combustion chamber.

Excessive smoke

- Worn cylinder, piston or piston rings
- Improper installation of piston rings
- Scored or scratched piston or cylinder wall

Abnormal noise (piston)

- Worn piston pin or piston pin hole
- Worn cylinder, piston or piston ring
- Worn connecting rod small end

CYLINDER

REMOVAL

Remove the following:

- Cam chain tensioner lifter if necessary (page 8-17)
- Cylinder head (page 8-11)
- Cam chain guide [1]

Do not strike the cylinder too hard and do not damage the mating surface with a screwdriver.

Lift the cylinder [2] and remove it, being careful not to damage the piston.

Clean the top of the cylinder thoroughly.

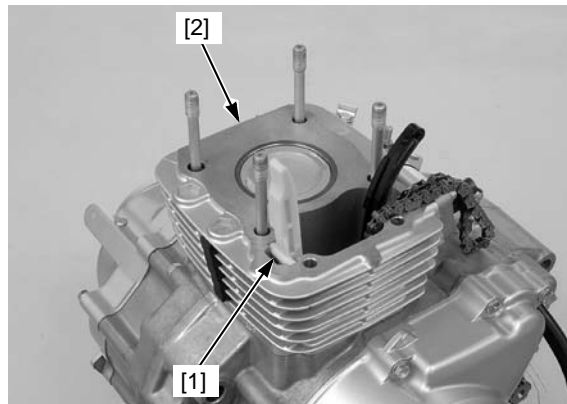

Remove the dowel pins [1] and gasket [2].

INSTALLATION

Be careful not to damage the mating surfaces. Do not allow gasket material to enter the crankcase.

Clean any gasket material from the cylinder mating surface of the crankcase.

Install the two dowel pins and a new gasket.

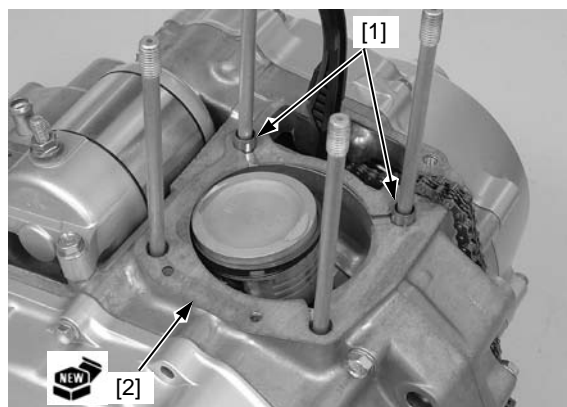

Apply engine oil to the cylinder wall, piston outer surface and piston rings.

Be careful not to damage the piston rings and cylinder wall.

Route the cam chain [1] through the cylinder [2] and install the cylinder over the piston [3] while compressing the piston rings [4] with your fingers.

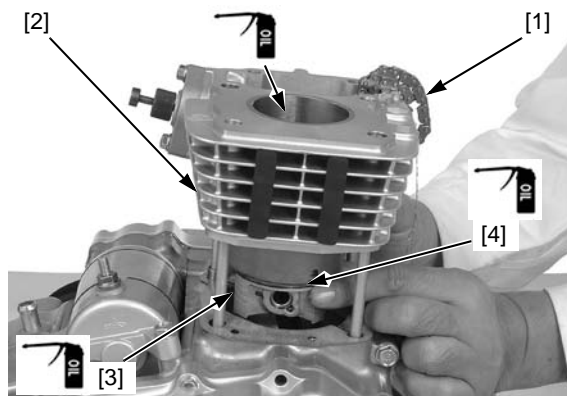

Insert the cam chain guide [1] into the cylinder and crankcase grooves [2].

Install the cylinder head (page 8-11).

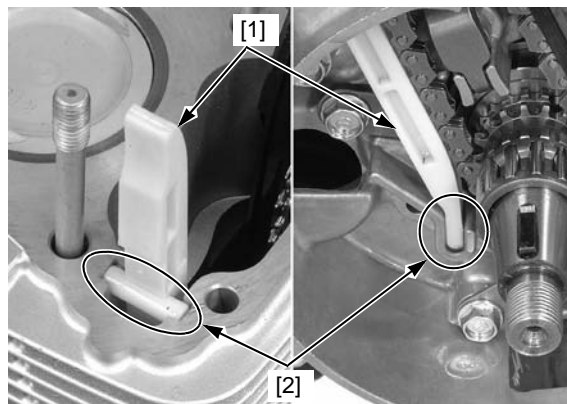

STUD BOLT REPLACEMENT

Thread two 8 mm nuts onto the stud bolt [1] and tighten them together, and use a wrench on them to turn the stud bolt out.

Install new stud bolts into the crankcase and tighten them

TORQUE: 11 N·m (1.1 kgf·m, 8 lbf·ft)

After installing the stud bolts, measure the stud height from the crankcase surface.

STANDARD: 113.4 – 115.4 mm (4.46 – 4.54 in)

Adjust the height if necessary.

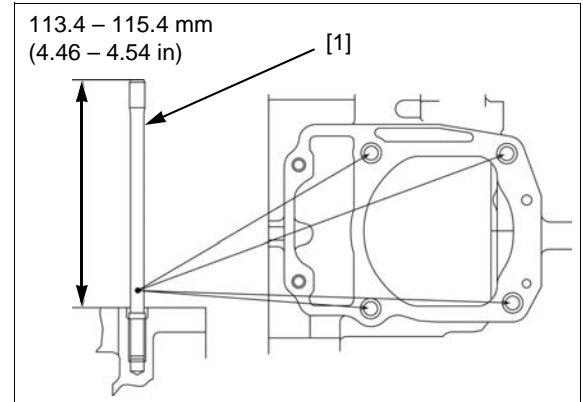

PISTON

REMOVAL

Place a clean shop towel over the crankcase to prevent the possibility of the clip falling into the crankcase.

Remove the piston pin clip [1] using the pair of pliers.

Push the piston pin [2] out of the piston and connecting rod, and remove the piston.

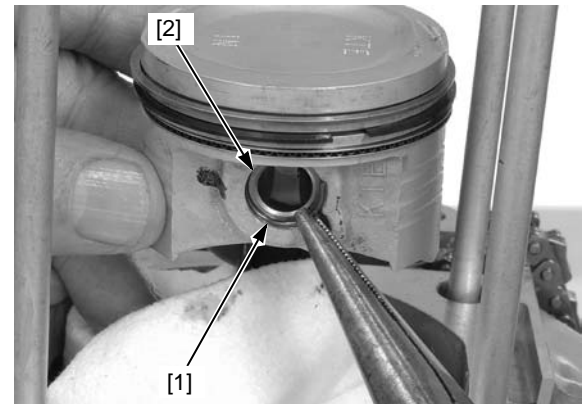

Do not damage the piston ring by spreading the ends too far. Spread each piston ring [1] and remove it by lifting it up at a point just opposite the gap.

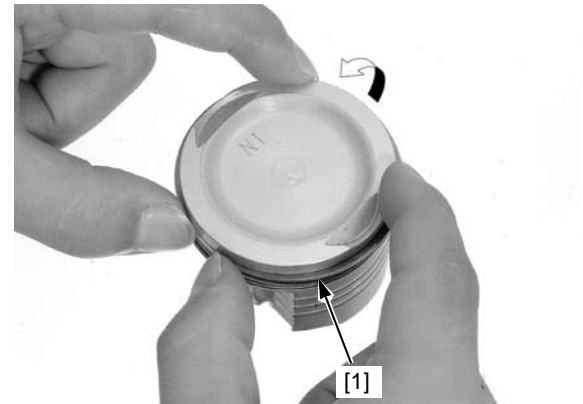

INSTALLATION

Carefully install the piston rings into the piston ring grooves with the markings facing up.

- Do not damage the piston ring by spreading the ends too far.
- Be careful not to scratch the piston surface.
- Do not confuse the top and second rings.

Stagger the ring end gaps 120 degrees apart from each other.
Stagger the side rail end gaps as shown.

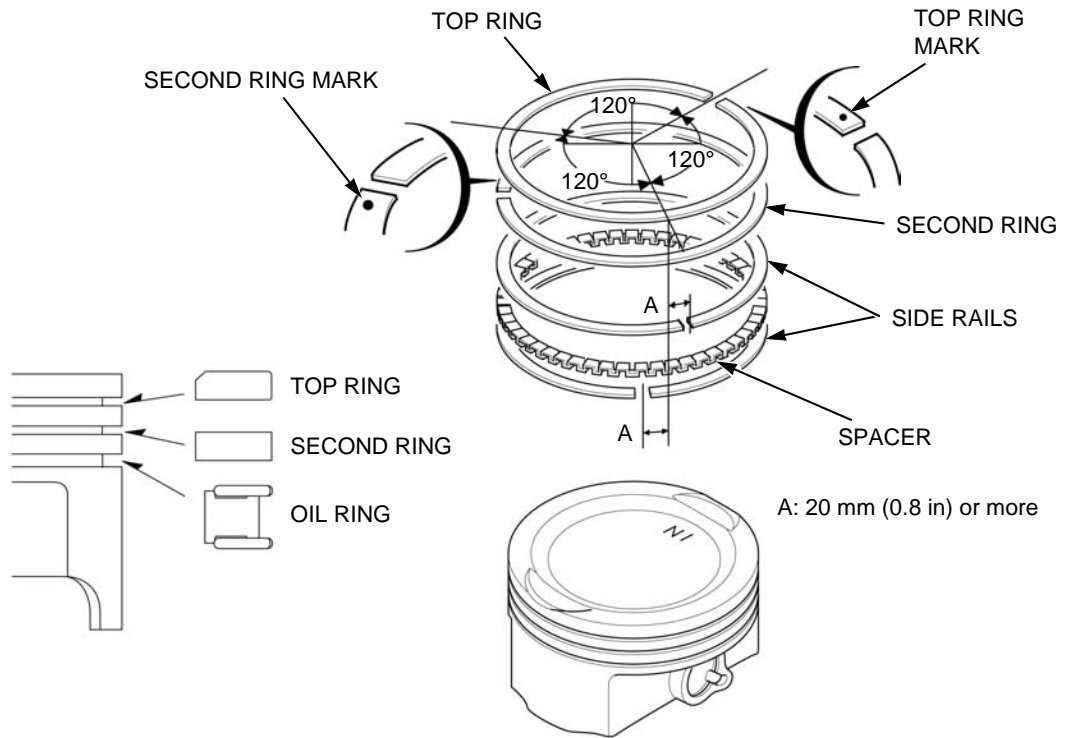

Apply molybdenum oil solution to the piston pin outer surface and connecting rod small end inner surface.
Apply engine oil to the piston pin hole [1].
Install the piston [2] with its "IN" mark [3] toward the intake side and insert the piston pin [4] through the piston and connecting rod.

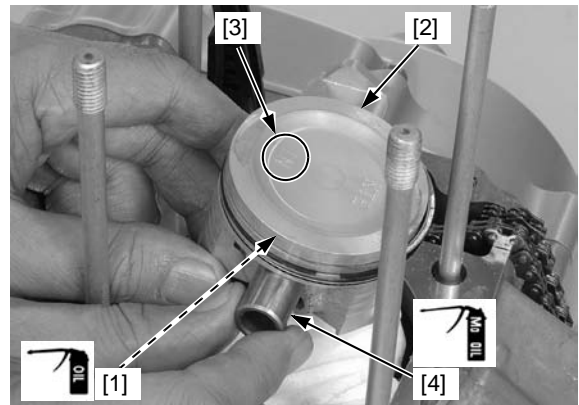

Place a shop towel over the crankcase opening to prevent piston pin clips from falling into the crankcase.

Install new piston pin clips [1] into the grooves in the piston pin hole.

- Make sure that the piston pin clips are seated securely.
- Do not align the piston pin clip end gap with the piston cutout.

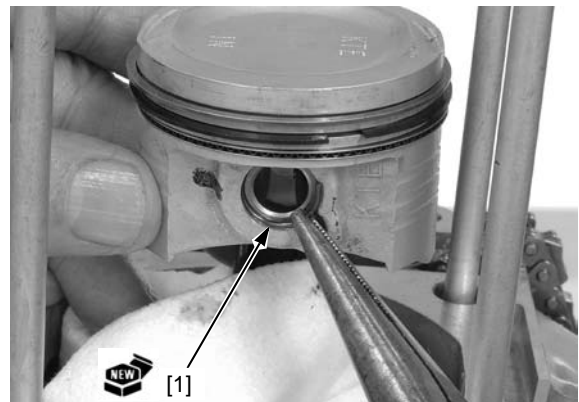

10. CLUTCH/GEARSHIFT LINKAGE

SYSTEM COMPONENTS.....	10-2	CLUTCH.....	10-7
SERVICE INFORMATION.....	10-3	GEARSHIFT LINKAGE.....	10-10
TROUBLESHOOTING.....	10-3	PRIMARY DRIVE GEAR.....	10-13
RIGHT CRANKCASE COVER	10-4		

CLUTCH/GEARSHIFT LINKAGE SYSTEM COMPONENTS

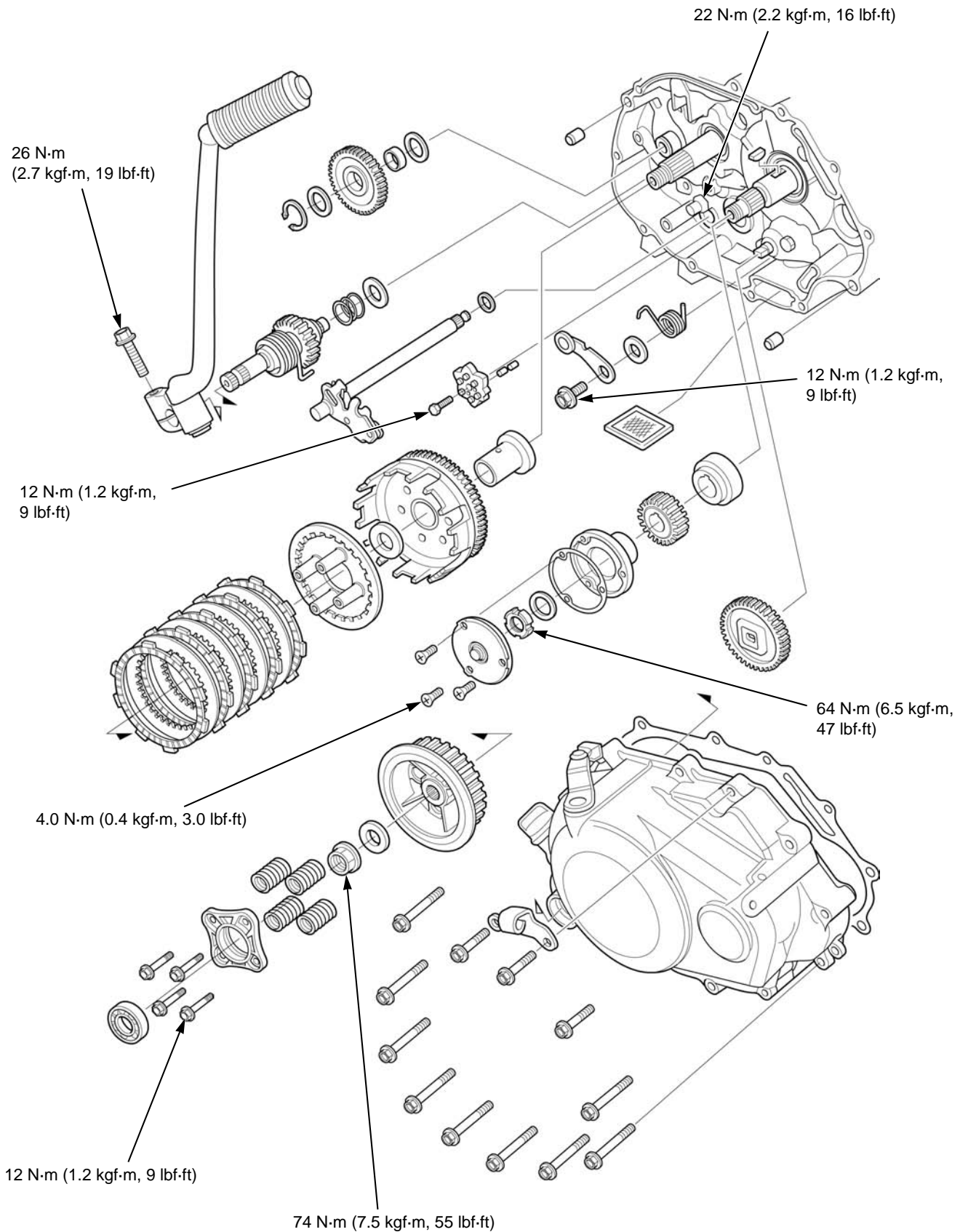

SERVICE INFORMATION

GENERAL

- This section covers service of the clutch, gearshift linkage and kickstarter. These services can be performed with the engine installed in the frame.
- Engine oil viscosity, oil level and the use of oil additives have an effect on clutch operation. Oil additives of any kind are specifically not recommended. When the clutch does not disengage or the vehicle creeps with the clutch disengaged, inspect the engine oil viscosity and oil level before servicing the clutch system.
- Engine lubricating oil is fed through the oil passages in the right crankcase cover. Clean the oil passages before installing the right crankcase cover.
- The crankcase must be separated to service the transmission, shift drum and shift forks (page 12-4).

TROUBLESHOOTING

Faulty clutch operation can usually be corrected by adjusting the freeplay.

Clutch lever difficult to pull in

- Damaged, kinked or dirty clutch cable
- Improperly routed clutch cable
- Damaged clutch lifter mechanism
- Faulty clutch lifter plate bearing

Clutch will not disengage or motorcycle creeps with clutch disengaged

- Excessive clutch lever free play
- Clutch plate warped
- Oil level too high, improper oil viscosity, or additive used

Clutch slips

- Clutch lifter sticking
- Worn clutch discs
- Weak clutch springs
- No clutch lever free play

Hard to shift

- Misadjusted clutch cable
- Damaged or bent shift fork
- Bent shift fork shaft
- Damaged gearshift spindle assembly
- Damaged shift drum guide grooves

Transmission jumps out of gear

- Worn shift drum stopper arm
- Worn or broken gearshift spindle return spring
- Bent shift fork shaft
- Damaged shift drum guide grooves
- Worn gear dogs or dog holes

Gearshift pedal will not return

- Weak or broken gearshift spindle return spring
- Bent gearshift spindle

CLUTCH/GEARSHIFT LINKAGE

RIGHT CRANKCASE COVER

REMOVAL

Drain the engine oil (page 3-7).

When removing the kickstarter pedal, mark the pedal position to ensure the original position.

Remove the bolt [1] and kickstarter pedal [2].

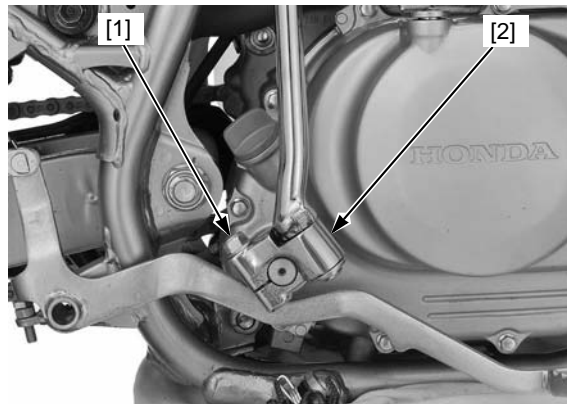

Remove the brake pedal return spring [1]. Disconnect the brake rod from the brake arm (page 15-4), then lower the brake pedal down.

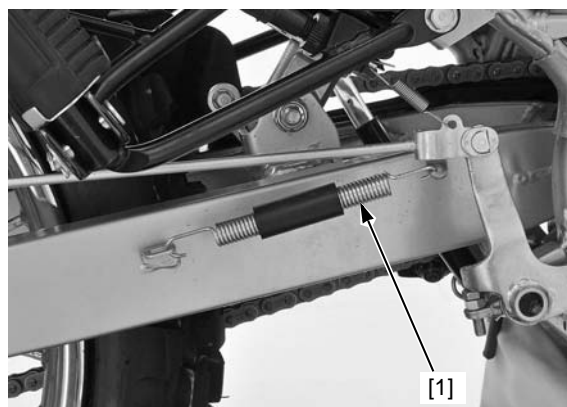

Remove the two bolts [1] and clutch cable stay [2], then disconnect the clutch cable.

Loosen the right crankcase cover bolts [3] in a crisscross pattern in 2 or 3 steps. Remove the bolts and right crankcase cover [4].

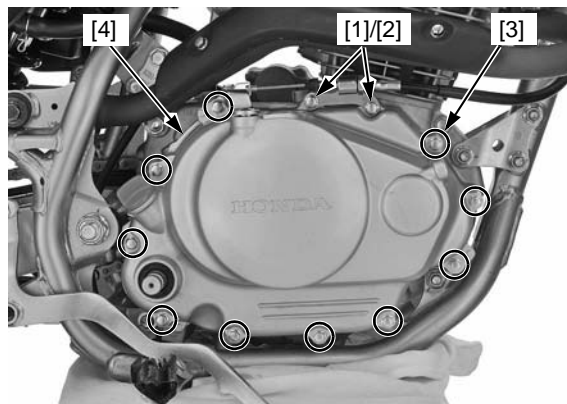

Remove the two dowel pins [1] and gasket [2].

INSTALLATION

Be careful not to damage the mating surfaces.

Clean off any gasket material from the right crankcase and cover mating surfaces.

Install the dowel pins and a new gasket.

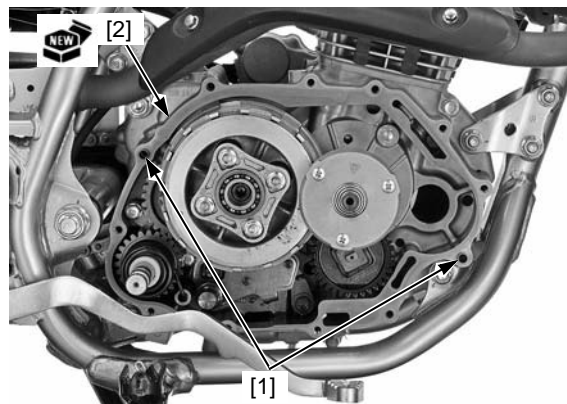

Install the right crankcase cover [1] and bolts [2].
Connect the clutch cable to the clutch lifter arm, then install the clutch cable stay [3] and two bolts [4].
Tighten the bolts in a crisscross pattern in 2 or 3 steps.

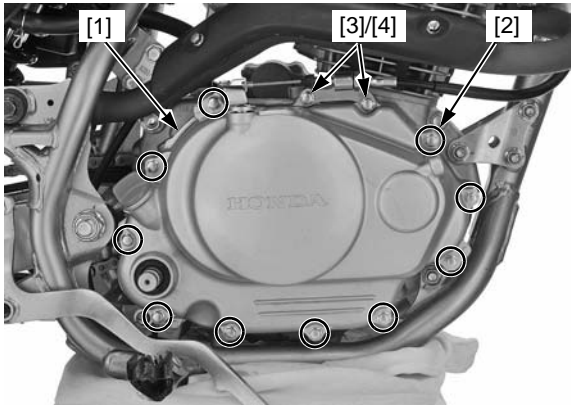

Install the brake pedal return spring [1].
Connect the brake rod from the brake arm (page 15-7).

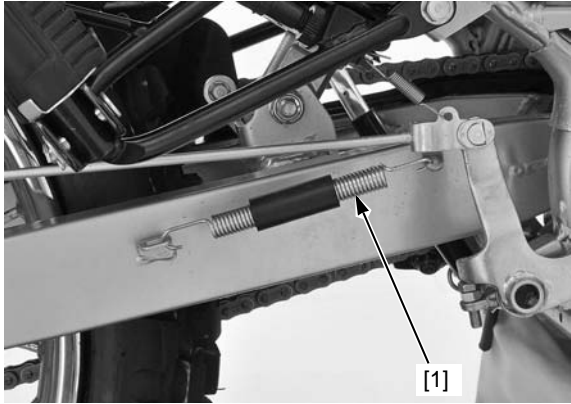

Install the kickstarter pedal [1] in the original position as noted during removal and tighten the bolt [2].
TORQUE: 26 N·m (2.7 kgf·m, 19 lbf·ft)
Fill the crankcase with the recommended engine oil (page 3-7).
Adjust the brake pedal freeplay (page 3-14).

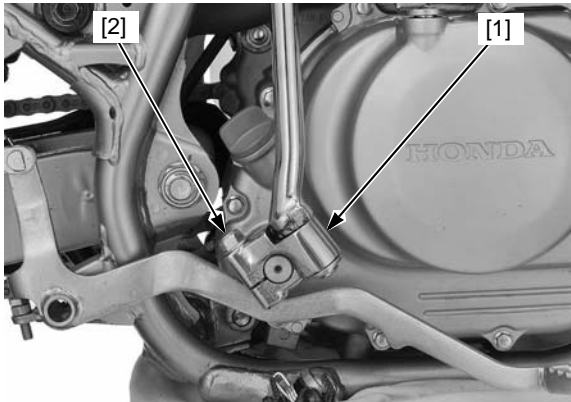

DISASSEMBLY

Remove the right crankcase cover (page 10-4).
Remove the clutch lifter piece [1] by turning the lifter arm clockwise slightly.
Drive the spring pin [2] into the clutch lifter arm [3] until the pin end is flush with the lifter arm surface, using the pin driver.

TOOL:
[4] Pin driver 07744-0010200

Pull the clutch lifter arm out and remove the return spring [5].

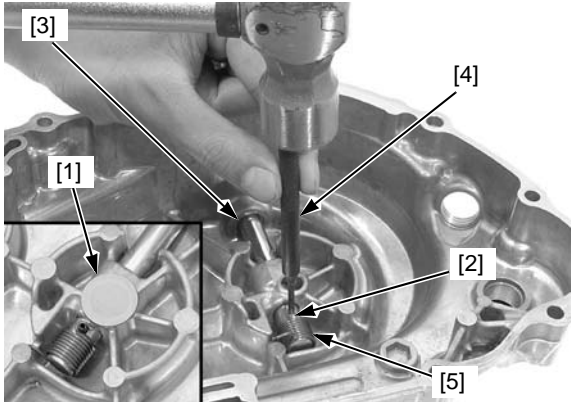

CLUTCH/GEARSHIFT LINKAGE

Remove the kickstarter spindle dust seal [1].
 Remove the clutch lifter arm [2] and dust seal [3].
 Check the lifter piece and arm for wear or damage.
 Check the return spring for fatigue or damage.
 Replace them if necessary.

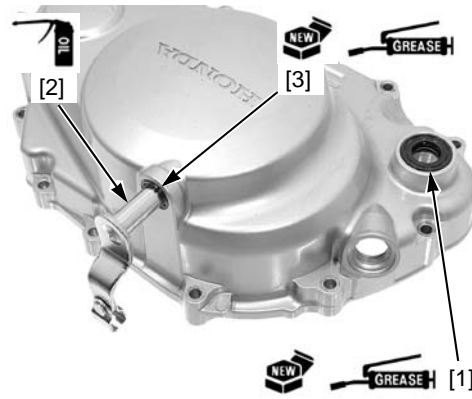

ASSEMBLY

Apply grease to lip of a new kickstarter spindle dust seal and install it into the right crankcase cover as specified.

Apply grease to lip of a new clutch lifter arm dust seal and install it into the right crankcase cover as specified.

Apply engine oil to the clutch lifter arm sliding surface and install it into the right crankcase cover.

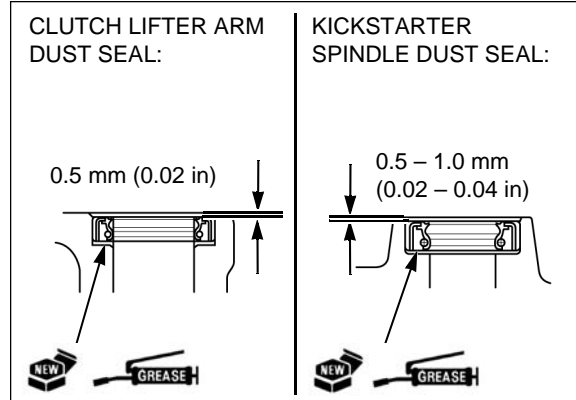

Install the return spring [1] onto the lifter arm end.

Hook the return spring ends to the right crankcase cover and spring pin.
 From the opposite side, drive the spring pin [2] until it projects as specified, using the pin driver.

TOOL:
[3] Pin driver **07744-0010200**

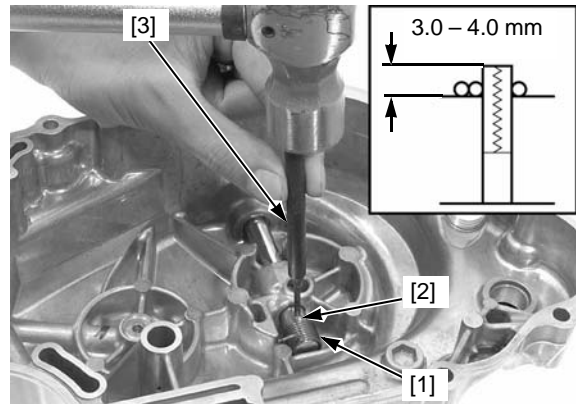

Install the lifter piece [1] into the lifter arm groove while turning the lifter arm [2] clockwise slightly.

Install the right crankcase cover (page 10-4).

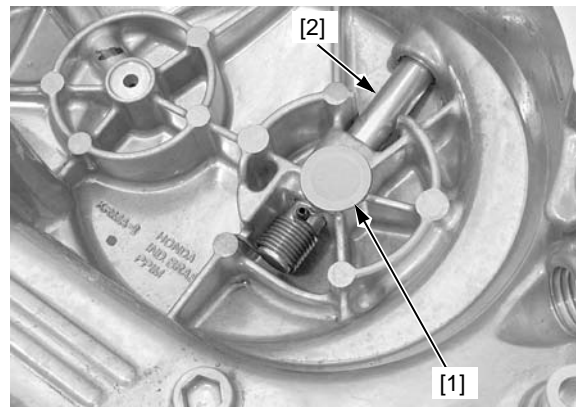

CLUTCH

REMOVAL

Remove the following:

- Right crankcase cover (page 10-4)
- Oil pump driven gear [1]
- Screws [2]
- Oil filter rotor cover [3] and gasket [4]

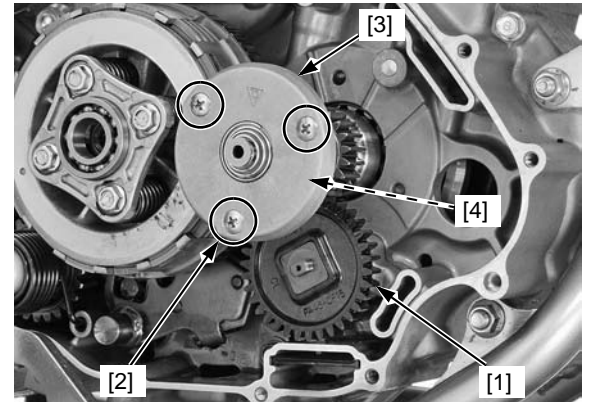

Install the gear holder between the primary drive and driven gears, and loosen the oil filter rotor lock nut [1].

TOOLS:

- | | |
|---------------------|---------------|
| [2] Gear holder | 07724-0010200 |
| [3] Lock nut wrench | 07716-0020100 |

Remove the lock nut, washer [4] and oil filter rotor [5].

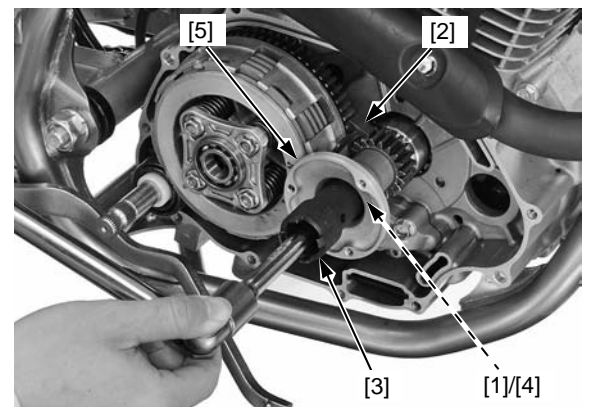

Loosen the clutch lifter plate bolts [1] in a crisscross pattern in several steps.

Remove the bolts, lifter plate [2] and clutch springs [3].

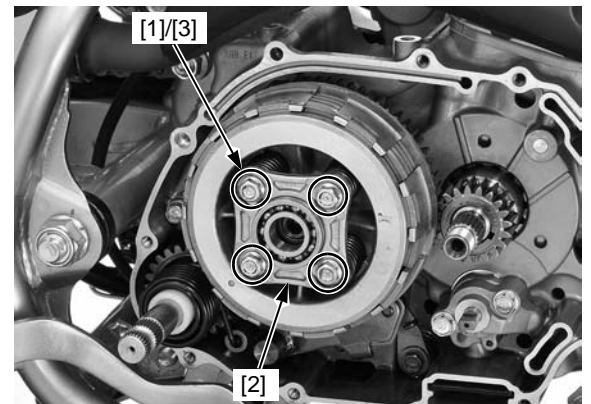

Attach the clutch center holder [1] to the pressure plate using the four clutch lifter plate bolts to hold the clutch center, and then loosen the lock nut [2].

TOOL:

- | | |
|----------------------|---------------|
| Clutch center holder | 07GMB-KT70101 |
|----------------------|---------------|

Remove the lock nut, then the clutch center holder.

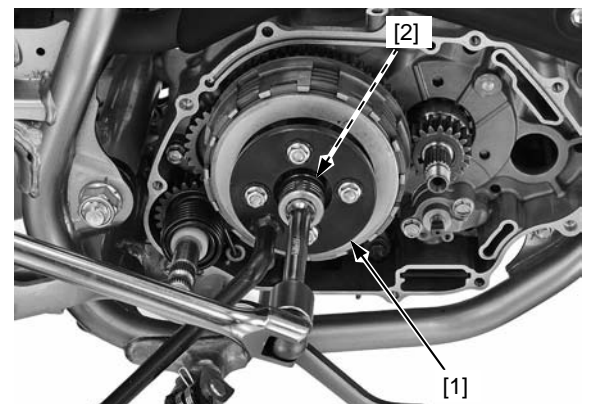

CLUTCH/GEARSHIFT LINKAGE

Remove the following:

- Washer [1]
- Clutch center [2]
- Clutch discs [3]/clutch plates [4]
- Pressure plate [5]
- Thrust washer [6]
- Clutch outer [7]

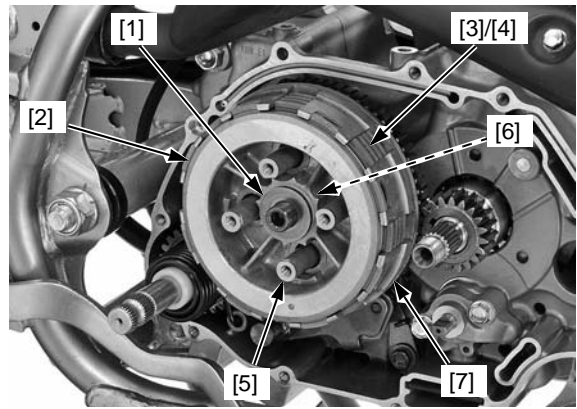

- Clutch outer guide [1]

INSTALLATION

Apply molybdenum oil solution to the outer surface of the clutch outer guide and install it onto the mainshaft.

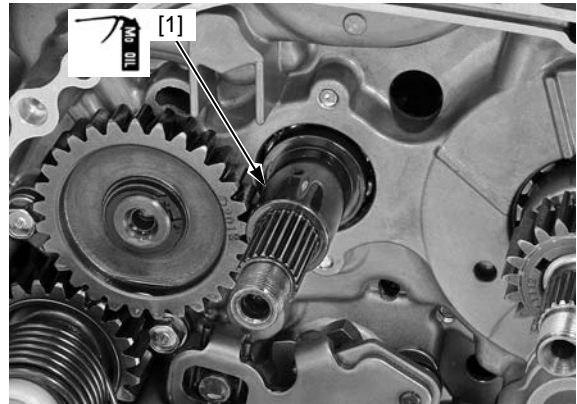

Apply engine oil to the primary driven gear teeth. Install the clutch outer [1] and thrust washer [2].

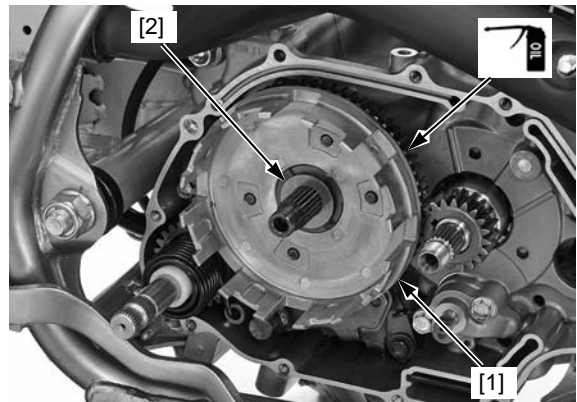

Coat the clutch discs with engine oil.

Install the clutch disc A [1], four clutch plates [2] and three discs B [3] alternately, and clutch disc A onto the clutch center [4].

Install the pressure plate [5] onto clutch center by aligning the "o" marks as shown.

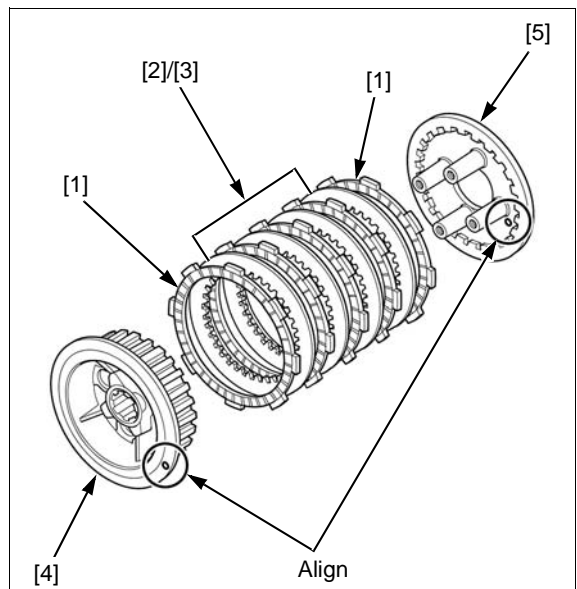

CLUTCH/GEARSHIFT LINKAGE

Install the tabs of clutch disc A (out side) into the shallow slots [3] in the clutch outer.

Install the clutch center assembly [1] into the clutch outer [2].

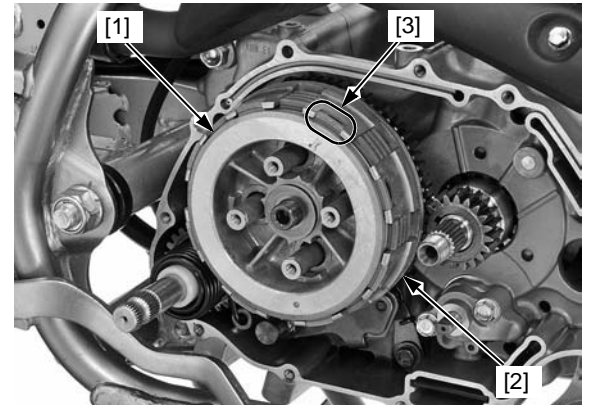

Apply engine oil to the threads and seating surface of the clutch center lock nut [1].
Install the lock nut onto the mainshaft.

Attach the clutch center holder to the pressure plate using four clutch lifter plate bolts to hold the clutch center, and then tighten the lock nut.

TOOL:

[2] Clutch center holder 07GMB-KT70101

TORQUE: 74 N·m (7.5 kgf·m, 55 lbf·ft)

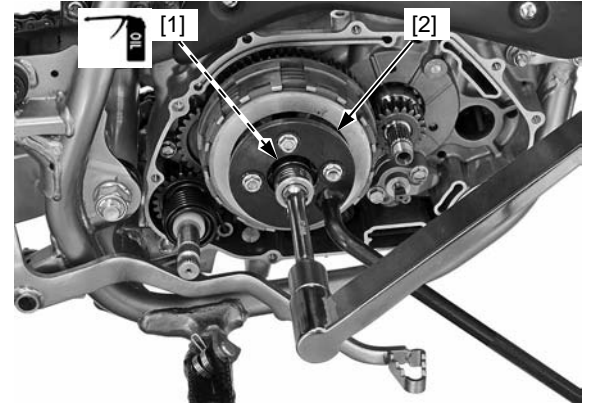

Install the clutch springs [1], lifter plate [2] and bolts [3].
Tighten the bolts in a crisscross pattern in several steps.

TORQUE: 12 N·m (1.2 kgf·m, 9 lbf·ft)

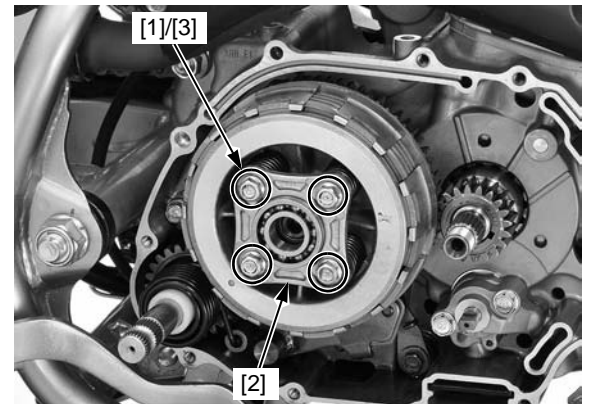

Install the oil filter rotor [1] and washer [2] onto the crankshaft.

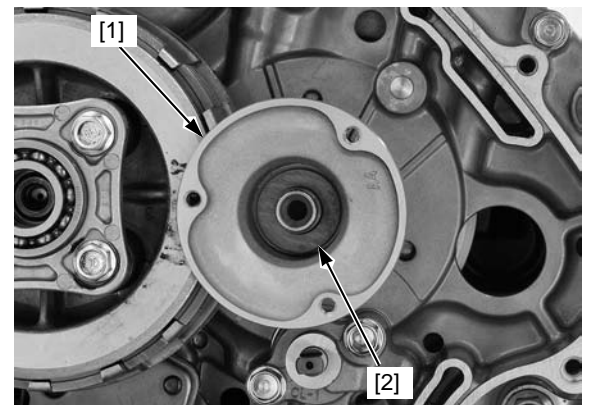

CLUTCH/GEARSHIFT LINKAGE

Apply engine oil to the threads and seating surface of the oil filter rotor lock nut [1], and then install it.

Install the gear holder between the primary drive and driven gears, and tighten the oil filter rotor lock nut.

TOOLS:

[2] Gear holder 07724-0010200

[3] Lock nut wrench 07716-0020100

TORQUE: 64 N·m (6.5 kgf·m, 47 lbf·ft)

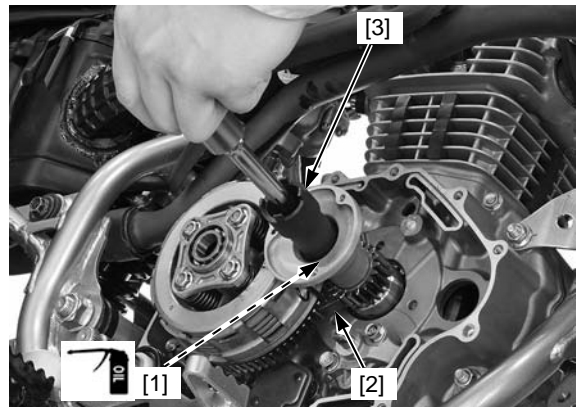

Install a new gasket [1] onto the oil filter rotor cover [2].

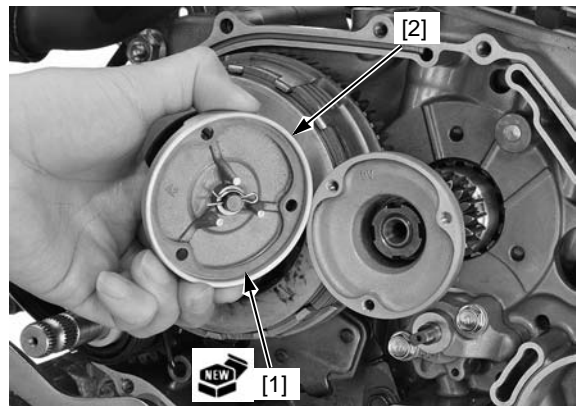

Install the oil filter rotor cover [1] and screws [2]. Tighten screws to the specified torque.

TORQUE: 4.0 N·m (0.4 kgf·m, 3.0 lbf·ft)

Install the oil pump driven gear [3].

Install the right crankcase cover (page 10-4).

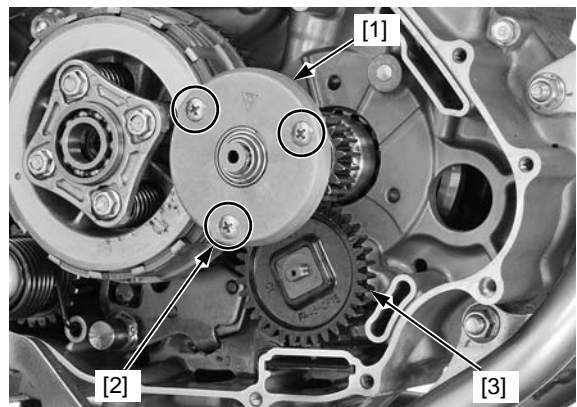

GEARSHIFT LINKAGE

REMOVAL/INSPECTION

Remove the clutch (page 10-7).

When removing the gearshift pedal, mark the pedal position to ensure the original position.

Remove the bolt [1] and gearshift pedal [2].

Clean the left end of the gearshift spindle.

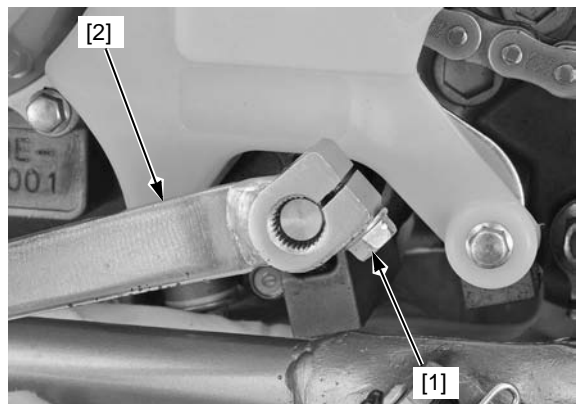

CLUTCH/GEARSHIFT LINKAGE

Pull the gearshift spindle [1] out of the crankcase being careful not to damage the oil seal lip, and remove the thrust washer [2] from the spindle.

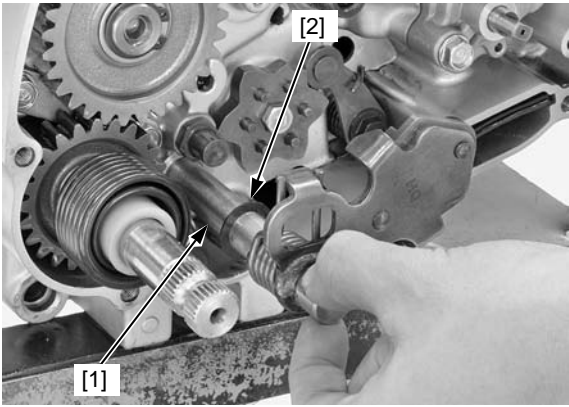

Remove the following:

- Gearshift cam bolt [1]
- Gearshift cam [2]

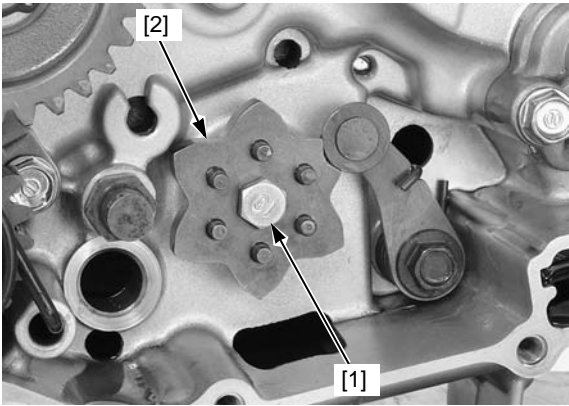

- Dowel pins [1]
- Stopper arm bolt [2]
- Stopper arm [3]
- Washer [4]
- Return spring [5]

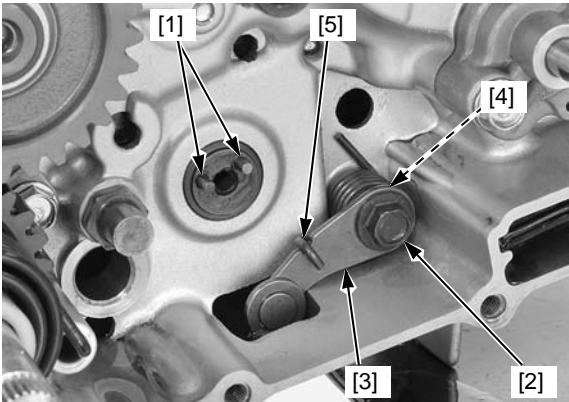

Inspect the gearshift spindle oil seal [1] for deterioration or damage, replace if necessary.

If replacing the oil seal, install it as specified.

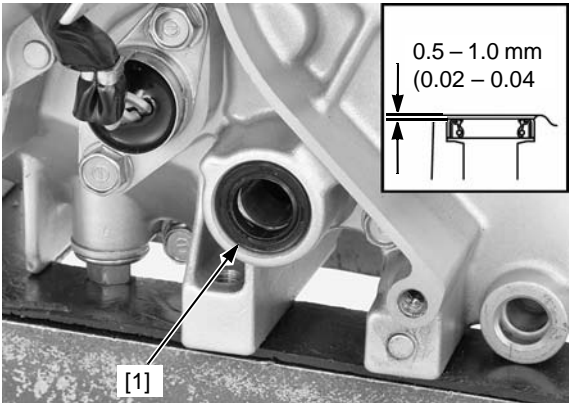

CLUTCH/GEARSHIFT LINKAGE

INSTALLATION

Apply locking agent to the stopper arm bolt threads. Install the return spring [1], washer [2], stopper arm [3] and bolt [4], while holding the spring end to the groove on the stopper arm. Tighten the stopper arm bolt to the specified torque.

TORQUE: 12 N·m (1.2 kgf·m, 9 lbf·ft)

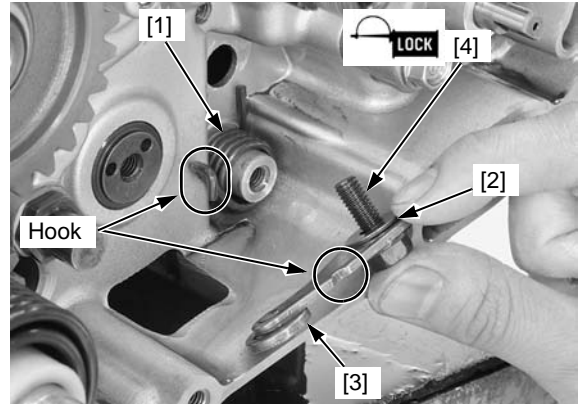

Install the dowel pins [1] into the shift drum holes.

Hold the stopper arm [2] using a screwdriver and install the gearshift cam [3] by aligning its holes [4] with the dowel pins.

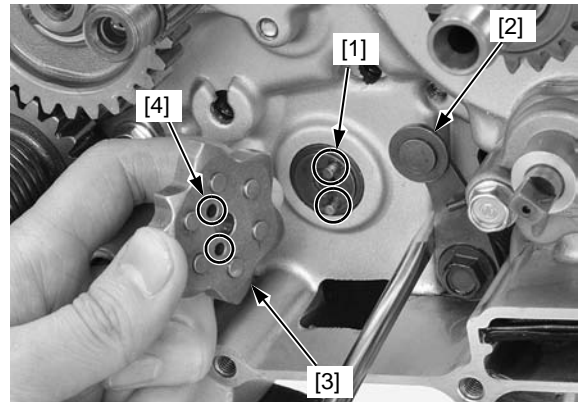

Apply locking agent to the gearshift cam bolt threads. Install the gearshift cam bolt [1] and tighten it.

TORQUE: 12 N·m (1.2 kgf·m, 9 lbf·ft)

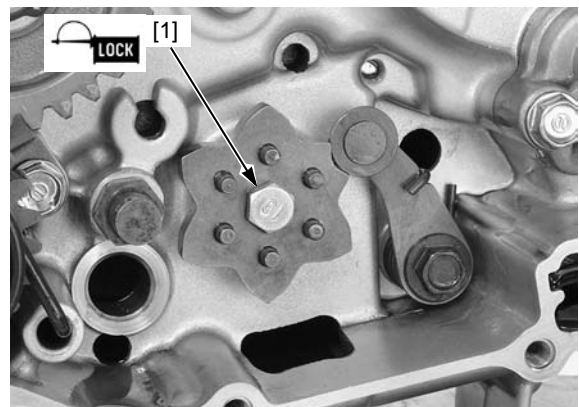

Check the gearshift spindle [1] for wear or bend. Check the spindle plate [2] for wear, damage or deformation. Check the return spring [3] for fatigue or damage.

Apply engine oil to the gearshift spindle journals. Install the thrust washer [4] onto the gearshift spindle and insert the spindle into the crankcase.

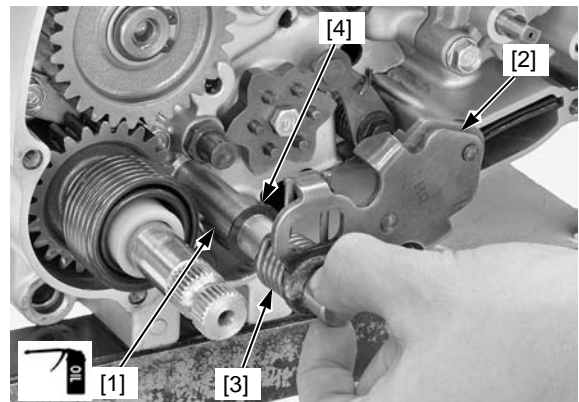

CLUTCH/GEARSHIFT LINKAGE

Be careful not to damage the oil seal lip in the left crankcase.

Install the spindle [1] over the spring pin by aligning the return spring ends with the spring pin.

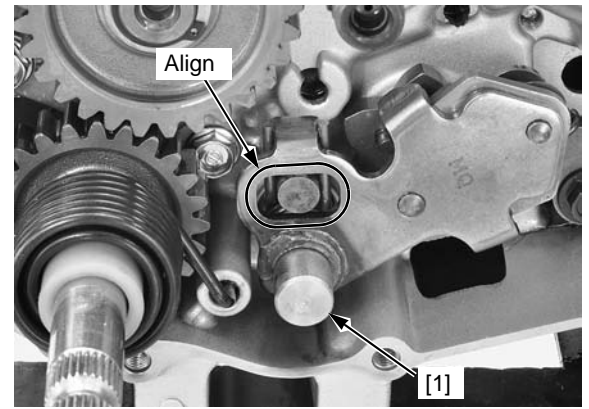

Install the clutch (page 10-8)

Install the gearshift pedal [1] in the original position as noted during removal.

Install the pinch bolt [2] and tighten it.

TORQUE: 12 N-m (1.2 kgf-m, 9 lbf-ft)

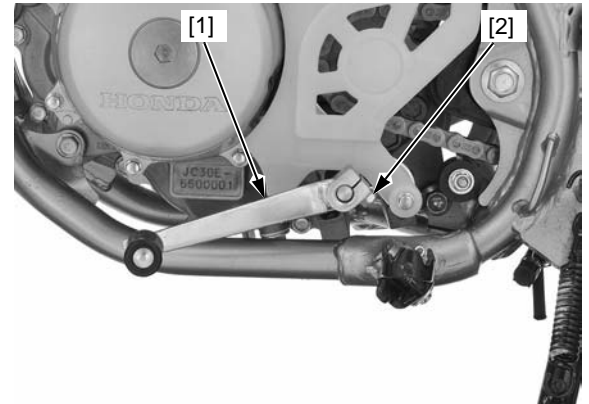

PRIMARY DRIVE GEAR

REMOVAL/INSTALLATION

Remove the clutch (page 10-7).

Be careful not to damage the crankshaft.

Remove the primary drive gear [1], spacer [2] and woodruff key [3].

Install the woodruff key into the crankshaft key groove.

Apply engine oil to the primary drive gear teeth.

Install the spacer and primary drive gear onto the crankshaft by aligning the key groove [4] with the woodruff key.

Install the clutch (page 10-8).

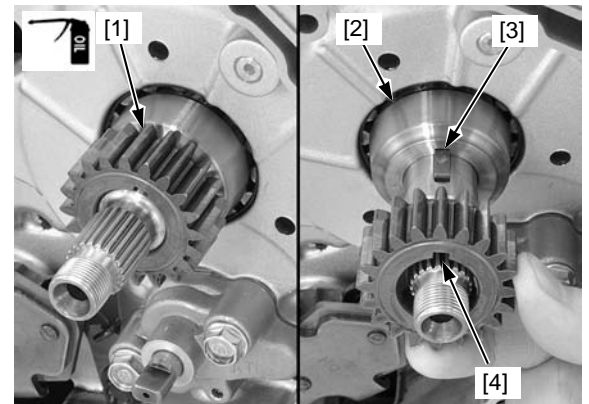

MEMO

11. ALTERNATOR/STARTER CLUTCH

SYSTEM COMPONENTS.....	11-2	STATOR/IGNITION PULSE GENERATOR	11-4
TROUBLESHOOTING.....	11-2	FLYWHEEL/STARTER CLUTCH	11-4
LEFT CRANKCASE COVER	11-3		

ALTERNATOR/STARTER CLUTCH SYSTEM COMPONENTS

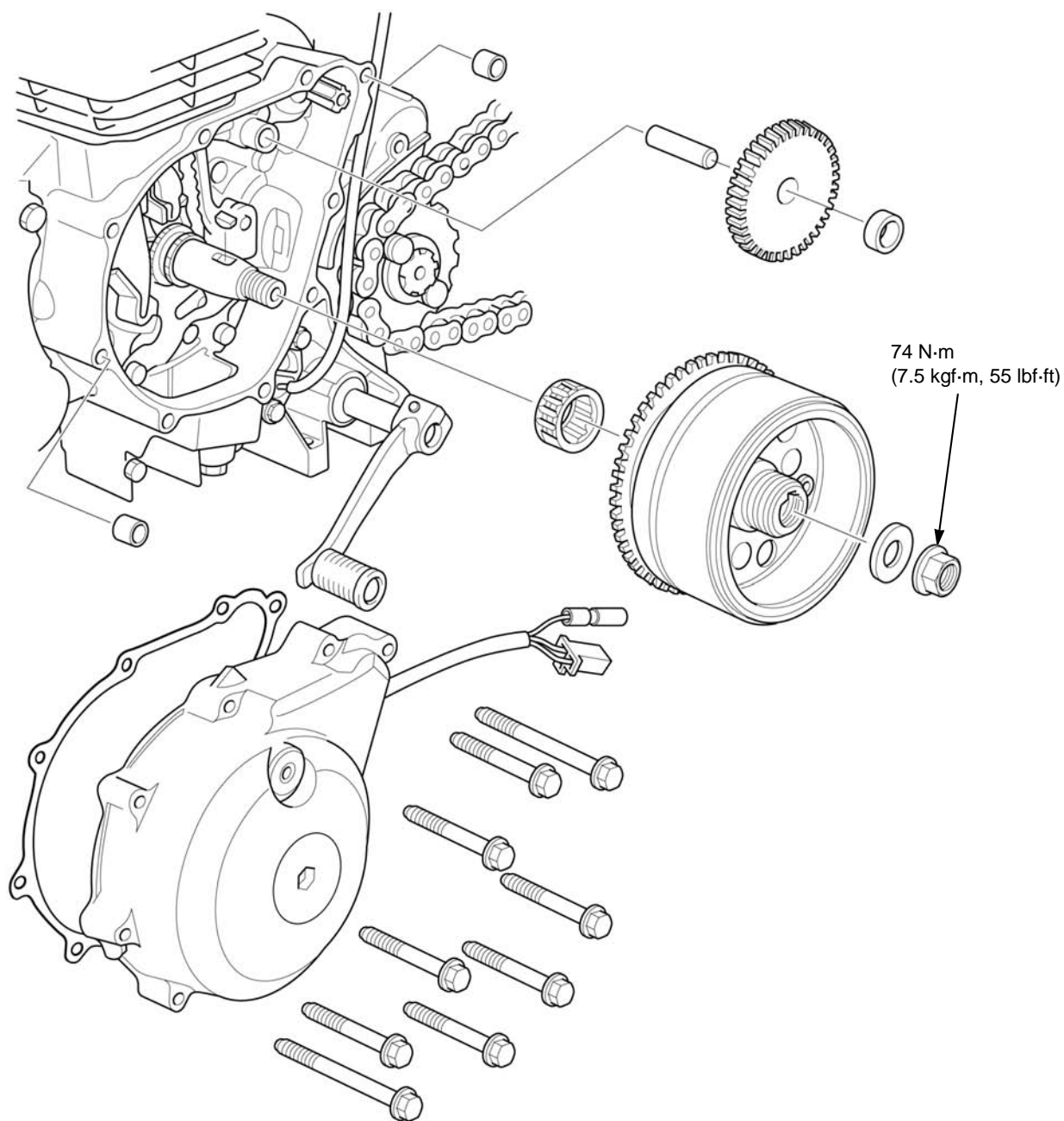

TROUBLESHOOTING

Starter motor turns, but engine does not turn

- Faulty starter clutch
- Damaged starter motor pinion gear, starter reduction gear or shaft

LEFT CRANKCASE COVER

REMOVAL

Drain the engine oil (page 3-7).

Remove the following:

- Left side cover (page 2-2)
- Drive sprocket cover (page 2-5)

Disconnect the alternator 2P connector [1] and ignition pulse generator (Blue/yellow) wire connector [2] from the connector boot.



Remove the neutral switch wire [1] from the left crankcase cover ribs [2].

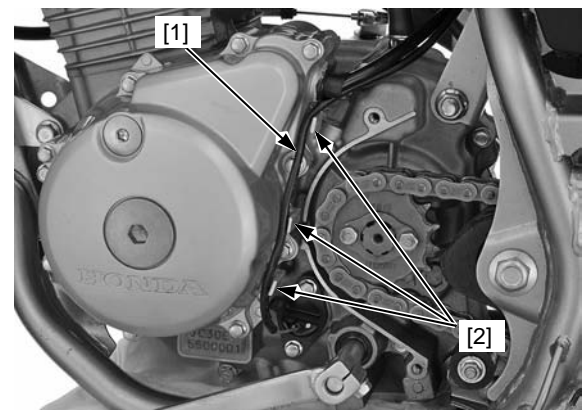

The left crankcase cover (stator) is magnetically attracted to the flywheel, be careful during removal.

Loosen the left crankcase cover bolts in a crisscross pattern in several steps. Remove the bolts [1] and left crankcase cover [2]. Remove the dowel pins [3] and gasket [4].

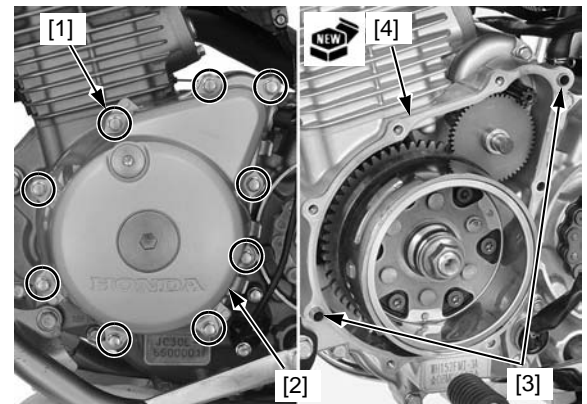

INSTALLATION

Be careful not to damage the mating surfaces.

Clean any gasket material from the mating surfaces of the left crankcase and cover.

Install the dowel pins and a new gasket.

Install the left crankcase cover and bolts, and tighten the bolts in a crisscross pattern in several steps.

Install the following:

- Drive sprocket cover (page 2-5)
- Left side cover (page 2-2)

Fill the crankcase with the recommended engine oil (page 3-7).

ALTERNATOR/STARTER CLUTCH

STATOR/IGNITION PULSE GENERATOR

REMOVAL

Remove the left crankcase cover (page 11-3).

Remove the following from the left crankcase cover:

- Socket bolt [1] and wire guide [2]
- Socket bolts [3] and ignition pulse generator [4]
- Socket bolts [5] and alternator stator assembly [6]
- Grommet [7]

INSTALLATION

Install the alternator stator assembly onto the left crankcase cover.

Install the three socket bolts and tighten them to the specified torque.

TORQUE: 12 N·m (1.2 kgf·m, 9 lbf·ft)

Apply liquid sealant to the wire grommet seating surface and install it into the cover groove.

Apply locking agent to the threads of the ignition pulse generator bolt and wire guide bolt.

Install the wire guide and ignition pulse generator onto the cover.

Install the bolts and tighten them to the specified torque.

TORQUE: 12 N·m (1.2 kgf·m, 9 lbf·ft)

Install the left crankcase cover (page 11-3).

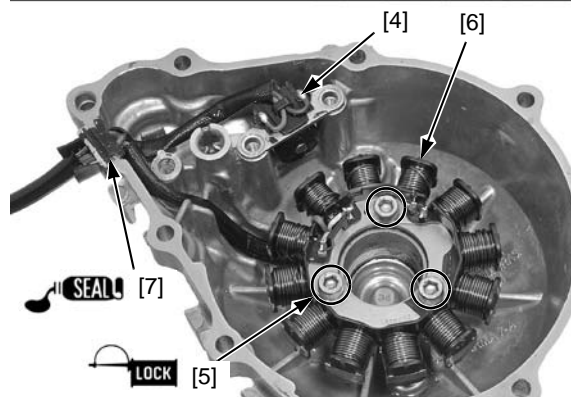
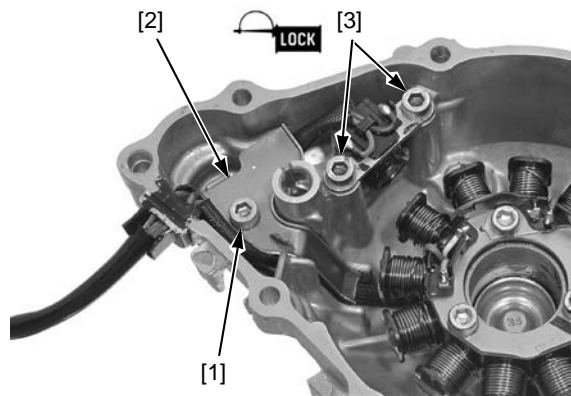

FLYWHEEL/STARTER CLUTCH

REMOVAL

Remove the left crankcase cover (page 11-3).

Remove the starter reduction gear shaft [1], collar [2] and reduction gear [3].

Hold the flywheel with the special tool and loosen the flywheel nut [1].

TOOL:

[2] Flywheel holder 07725-0040001

Remove the flywheel nut and washer [3].

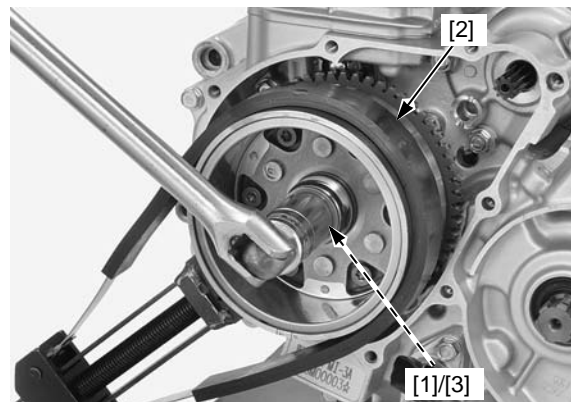
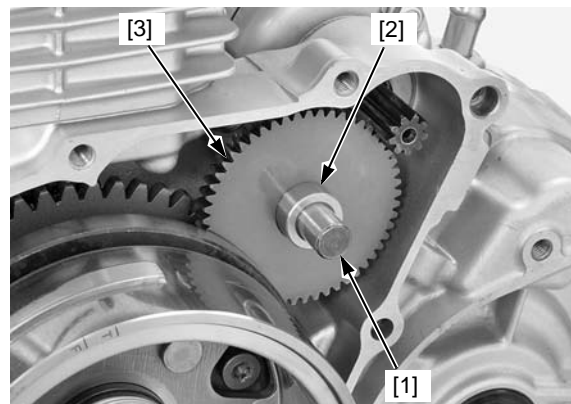

Remove the flywheel [1] using the special tool.

TOOL:
[2] Flywheel puller 07933-KM10000

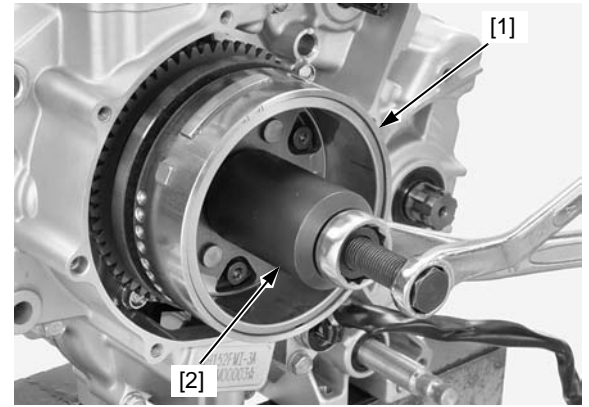

Be careful not to damage the crankshaft. Remove the woodruff key [1] and needle bearing [2].

INSTALLATION

Apply engine oil to the needle bearing and install it onto the crankshaft.

Install the woodruff key into the crankshaft key groove.

Clean any oil from the tapered portions of the crankshaft and flywheel.

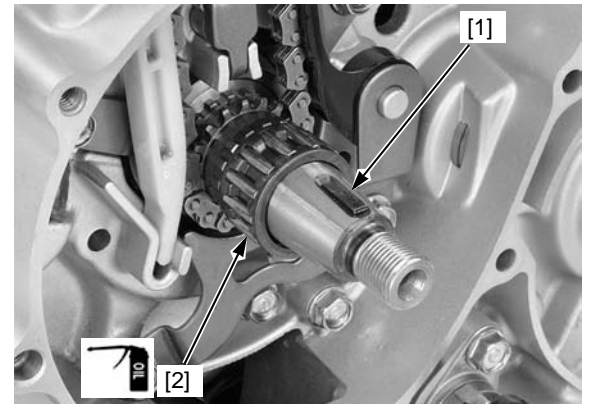

Install the flywheel [1] by aligning the key way with the key on the crankshaft.

Apply engine oil to the flywheel nut threads and seating surface.

Install the washer [2] and flywheel nut [3].

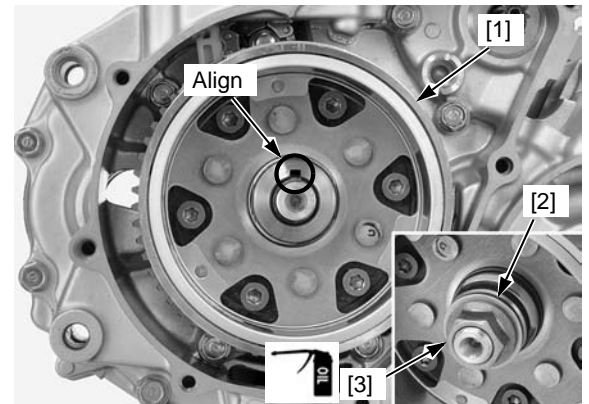

Hold the flywheel with the special tool and tighten the flywheel nut [1].

TOOL:
[2] Flywheel holder 07725-0040001

TORQUE: 74 N·m (7.5 kgf·m, 55 lbf·ft)

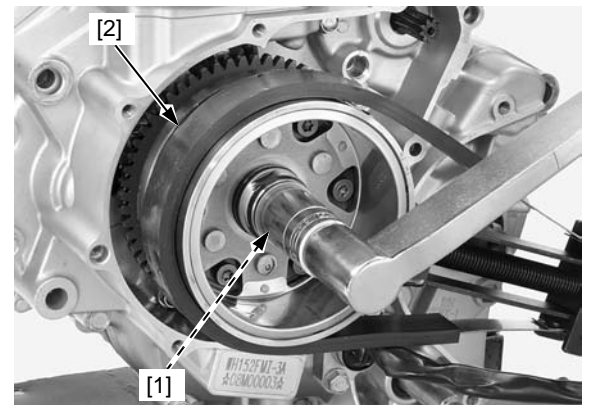

ALTERNATOR/STARTER CLUTCH

Apply engine oil to the starter reduction gear shaft [1].
Install the starter reduction gear [2], collar [3] and shaft.
Install the left crankcase cover (page 11-3).

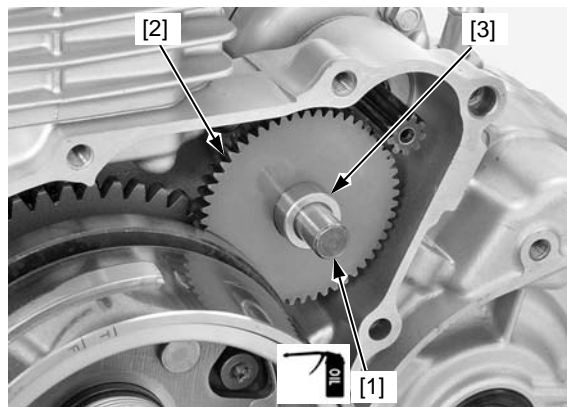

STARTER CLUTCH DISASSEMBLY/ ASSEMBLY

Disassemble and assemble the starter clutch as following illustration.

When loosening and tightening the starter clutch bolts [1], hold the flywheel using the special tool [2].

TOOL:

[2] Flywheel holder 07725-0040001

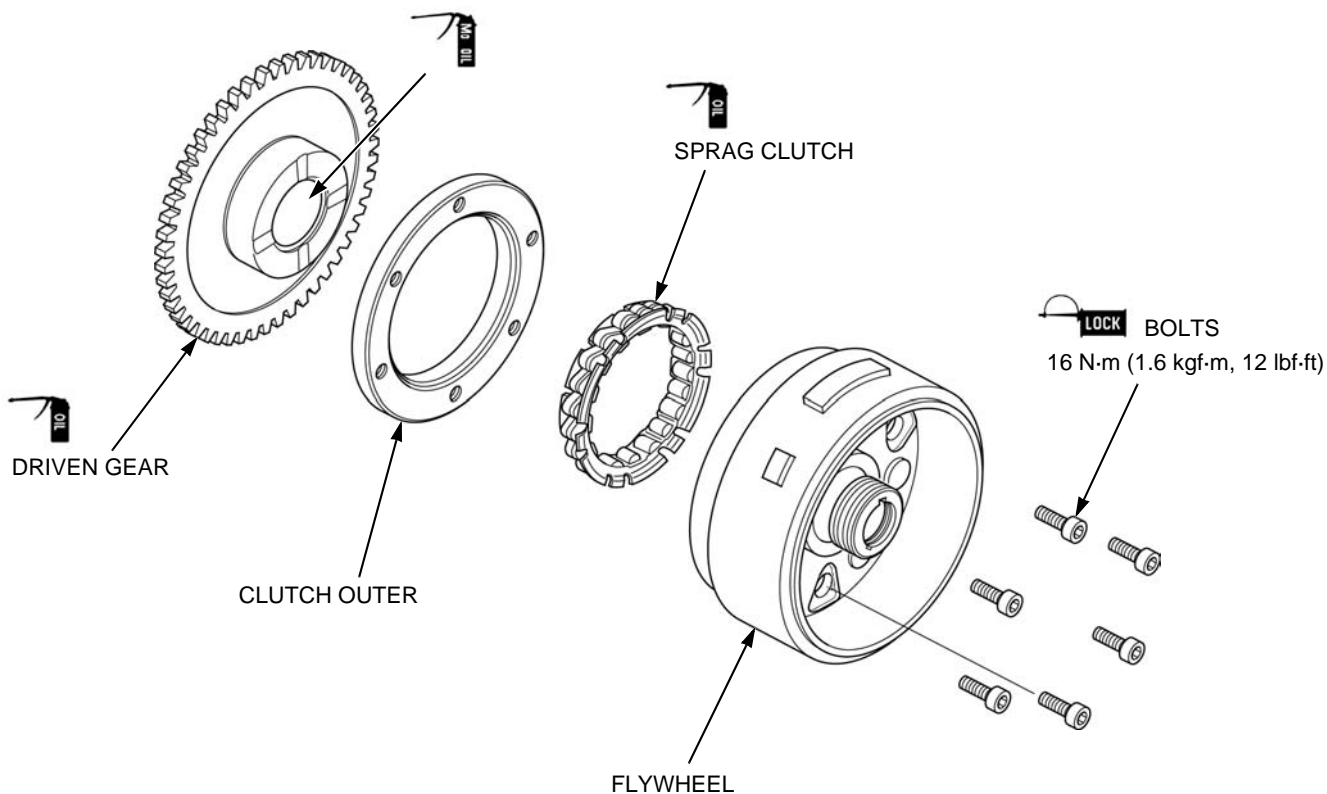
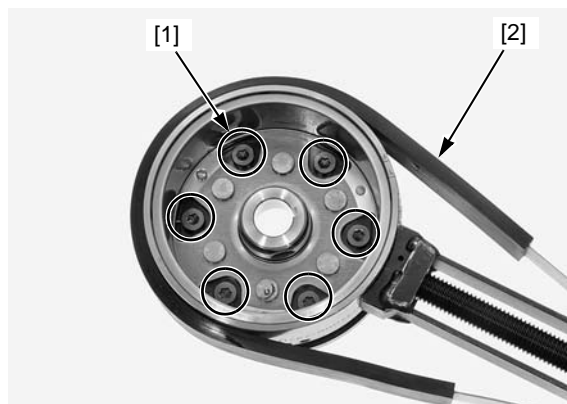

12. CRANKSHAFT/TRANSMISSION/KICKSTARTER

SYSTEM COMPONENTS.....	12-2	TRANSMISSION	12-8
SERVICE INFORMATION	12-3	CRANKSHAFT	12-13
TROUBLESHOOTING.....	12-3	KICKSTARTER IDLE GEAR	12-14
CRANKCASE SEPARATION/ASSEMBLY.....	12-4	KICKSTARTER	12-15

SYSTEM COMPONENTS

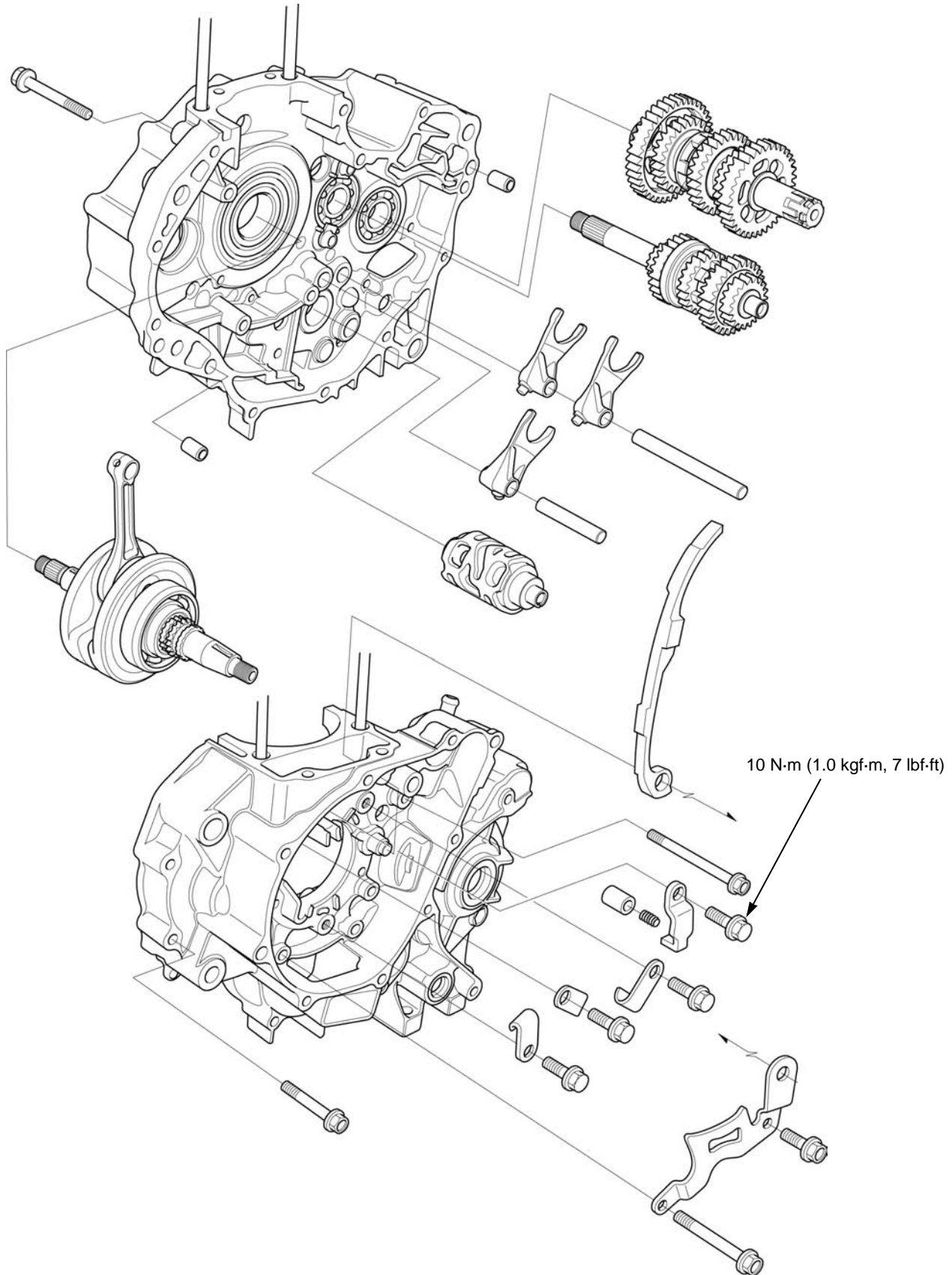

SERVICE INFORMATION

GENERAL

- The crankcase halves must be separated to service the transmission and crankshaft. To service these parts, the engine must be removed from the frame (page 13-3).
- Be careful not to damage the crankcase mating surfaces when servicing.
- Engine lubricating oil is fed through the oil passages in the crankcase. Clean the oil passages before assembling the crankcase halves.

TROUBLESHOOTING

Excessive noise

- Worn, sized or chipped transmission gear
- Worn or damaged transmission bearing
- Worn or damaged connecting rod bearing
- Worn connecting rod small end
- Worn crankshaft bearing

Hard to shift

- Bent shift fork
- Bent shift fork shaft
- Damaged shift drum guide groove
- Damaged shift fork guide pin

Transmission jumps out of gear

- Worn gear dogs or dog holes
- Worn shift drum guide groove
- Worn shift fork guide pin
- Worn gear shifter groove
- Worn shift fork shaft
- Bent shift fork shaft

CRANKCASE SEPARATION/ ASSEMBLY

Remove the following:

- Engine (page 13-3)
- Cylinder head (page 8-11)
- Cylinder and piston (page 9-4)
- Oil pump (page 7-3)
- Clutch (page 10-7)
- Kickstarter (page 12-15)
- Primary drive gear (page 10-13)
- Gearshift linkage (page 10-10)
- Flywheel (page 11-4)
- Starter motor (page 5-5)
- Neutral switch (page 18-9)
- Two bolts [1] and cam chain guide setting plate [2]
- Cam chain guide [3]
- Cam chain [4]
- Bolt [1] and push plug plate [2]
- Spring [3] and push plug [4]

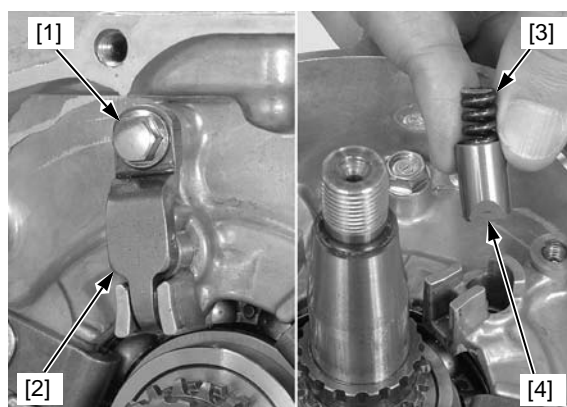
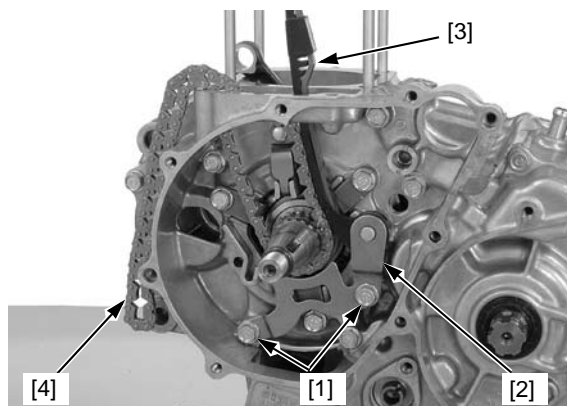

- Three bolts [1] and crankshaft bearing setting plates [2]

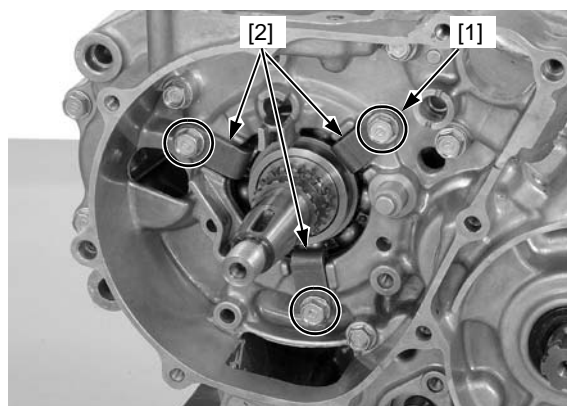

- Right crankcase bolt [1]

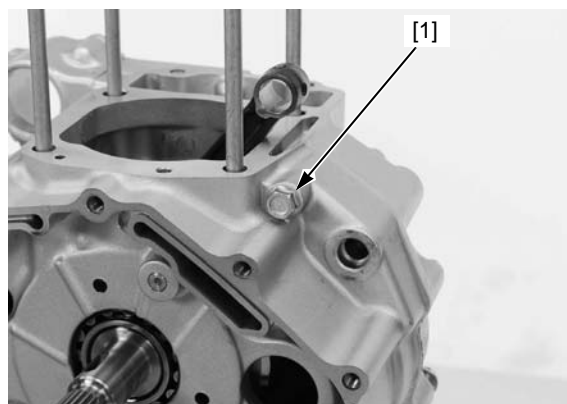

CRANKSHAFT/TRANSMISSION/KICKSTARTER

Loosen the thirteen left crankcase bolts [1] in a crisscross pattern in 2 or 3 steps, and remove them.

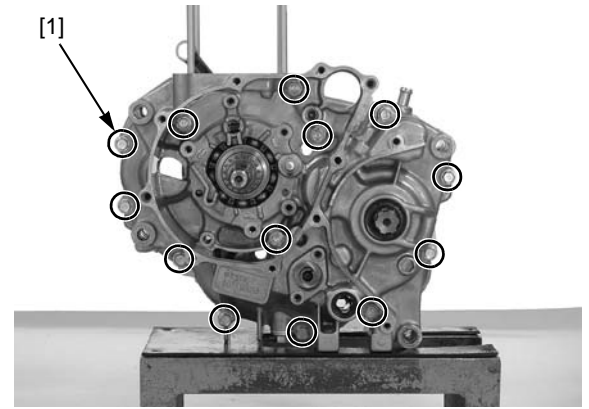

Place the crankcase assembly with the right side down.

Do not pry the crankcase halves.

Carefully separate the left crankcase [1] from the right crankcase [2] while tapping them at several locations with a soft hammer.

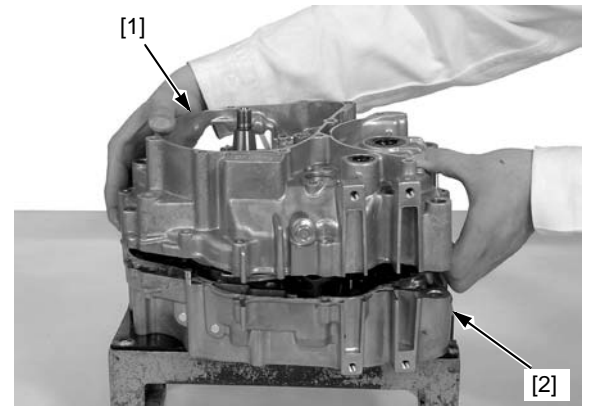

Remove the dowel pins [1].

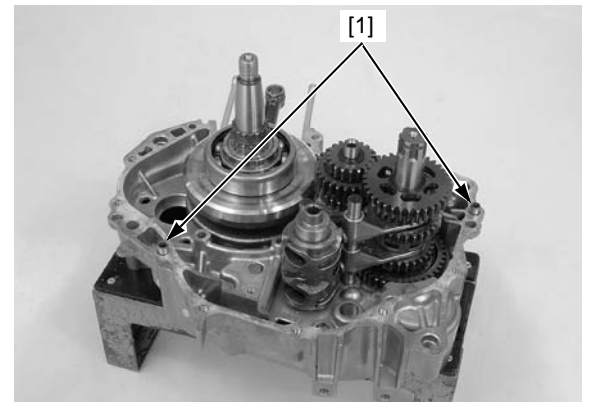

Remove the countershaft oil seal [1] from the left crankcase.

Apply grease to new gearshift spindle oil seal and countershaft oil seal lips and install them into the left crankcase.

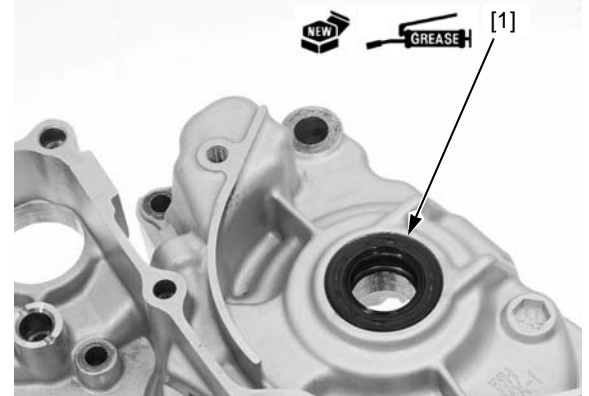

CRANKSHAFT/TRANSMISSION/KICKSTARTER

Clean the left and right crankcase mating surfaces thoroughly, being careful not to damage them.

Apply liquid sealant to the mating surface (shadowed area) of the left crankcase except the oil passage area as shown.

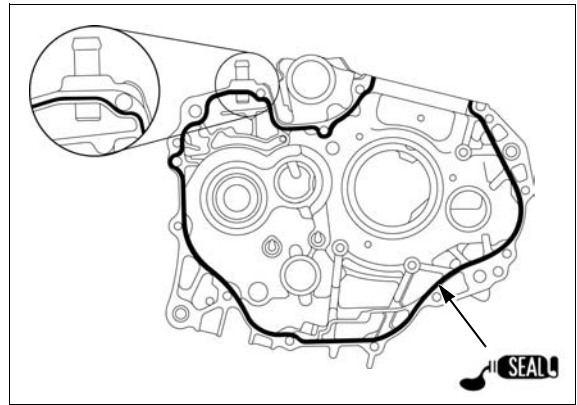

Install the two dowel pins [1].

Install the left crankcase over the right crankcase.

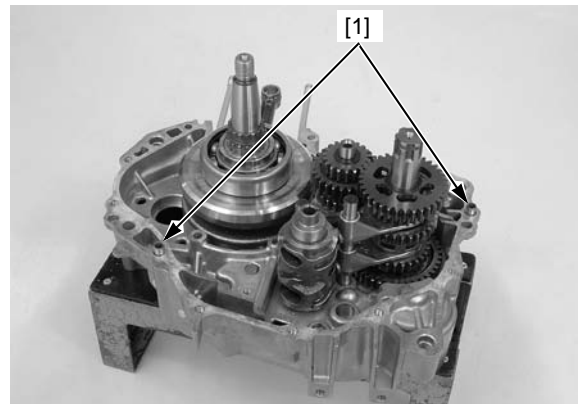

Install the thirteen left crankcase bolts [1], and tighten them in a crisscross pattern in 2 or 3 steps.

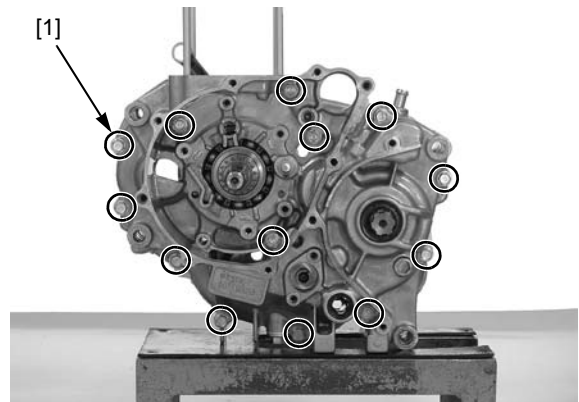

Install the right crankcase bolt [1] and tighten it.

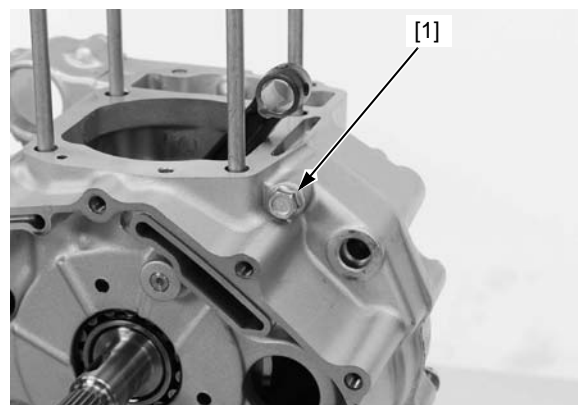

When installing the retainer plate, pull the crankshaft [3] and hook the plate tab to the crankshaft bearing groove as shown.

Install the bearing retainer plates [1] and bolts [2].
Tighten the bolts securely.

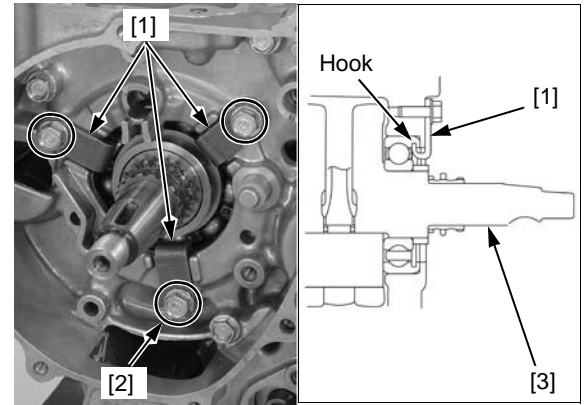

Apply molybdenum oil solution to the push plug entire surface.
Install the push plug [1] and spring [2] by aligning the tapered surfaces of the plug and crankshaft bearing outer race [3].

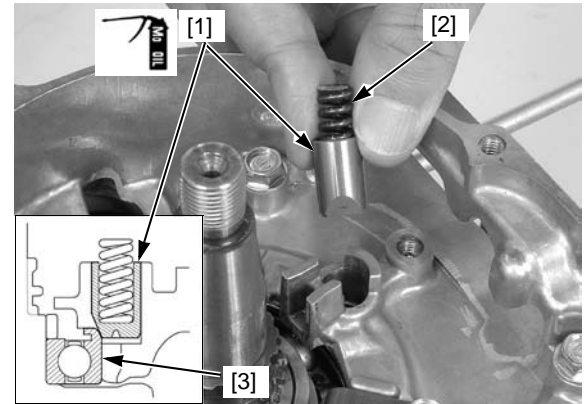

Apply locking agent to the push plug plate bolt threads.
Install the push plug plate [1] and bolt [2], and then tighten the bolt to the specified torque.

TORQUE: 10 N·m (1.0 kgf·m, 7 lbf·ft)

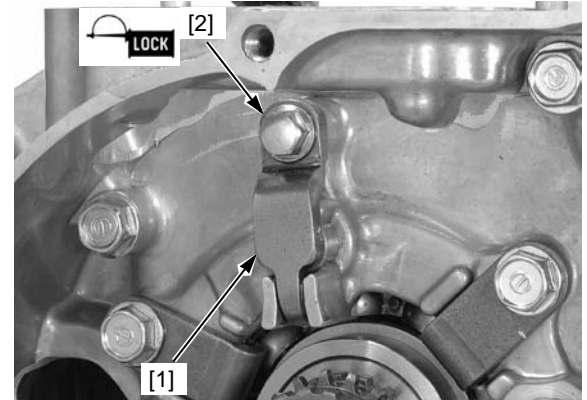

Install the cam chain [1] and cam chain guide [2].
Install the setting plate [3] with the two bolts [4] and tighten the bolts.

Install the following:

- Neutral switch (page 18-9)
- Starter motor (page 5-6)
- Flywheel (page 11-5)
- Gearshift linkage (page 10-12)
- Primary drive gear (page 10-13)
- Kickstarter (page 12-15)
- Clutch (page 10-8)
- Oil pump (page 7-3)
- Cylinder and piston (page 9-5)
- Cylinder head (page 8-11)
- Engine (page 13-5)

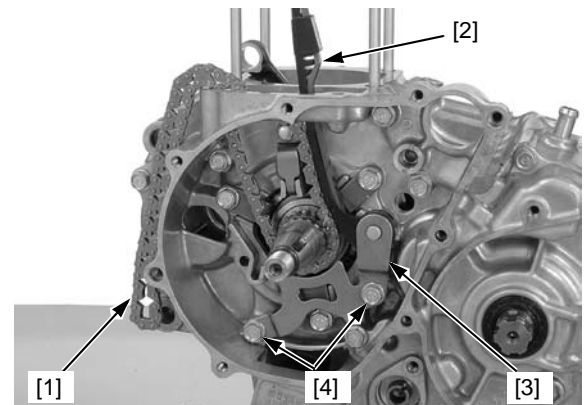

TRANSMISSION

DISASSEMBLY

Separate the crankcase halves (page 12-4).

Remove the shift fork shafts [1].

Remove the shift forks [2] and shift drum [3].

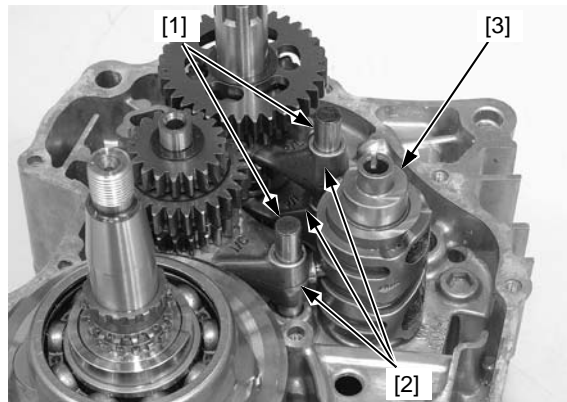

Remove the mainshaft [1] and countershaft [2] as an assembly.

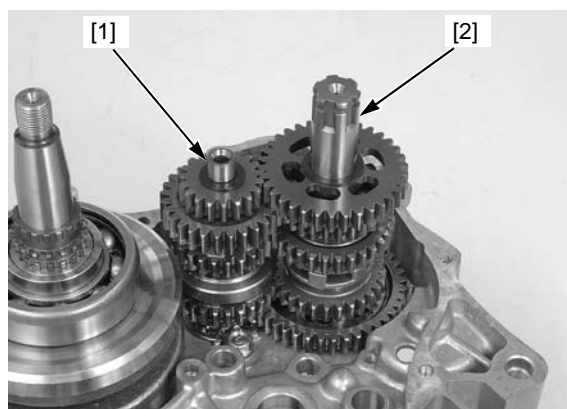

Disassemble the mainshaft [1] and countershaft [2].

Keep track of the disassembled parts (gears, bushings, washers, and snap rings) by stacking them on a tool or slipping them onto a piece of wire.

Clean disassembled parts in solvent thoroughly.

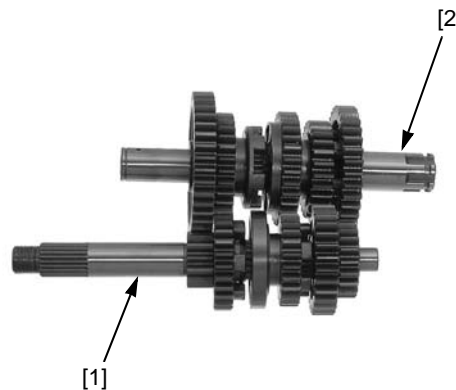

ASSEMBLY

Apply molybdenum oil solution to the gear and bushing sliding surfaces.

Assemble all parts into their original positions.

- Check the gears for freedom of movement or rotation on the shaft.
- Do not reuse worn snap ring which could easily spin in the groove.
- Always install the thrust washers and snap ring with the chamfered (rolled) edge facing away from the thrust load.
- Install the snap ring [1] so its ends align with the grooves in the splines.
- Make sure the snap ring is fully seated in the shaft groove after installing it.

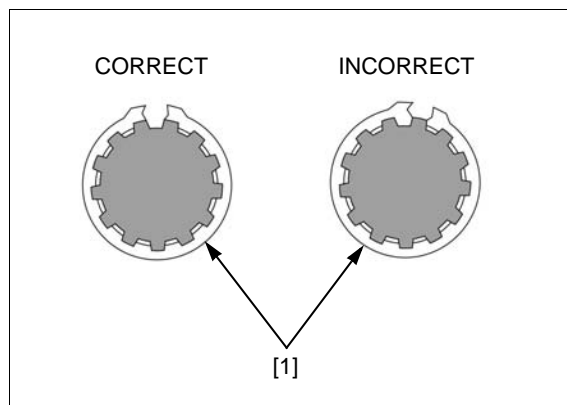

MAINSHAFT

 : Gear and bushing sliding surfaces

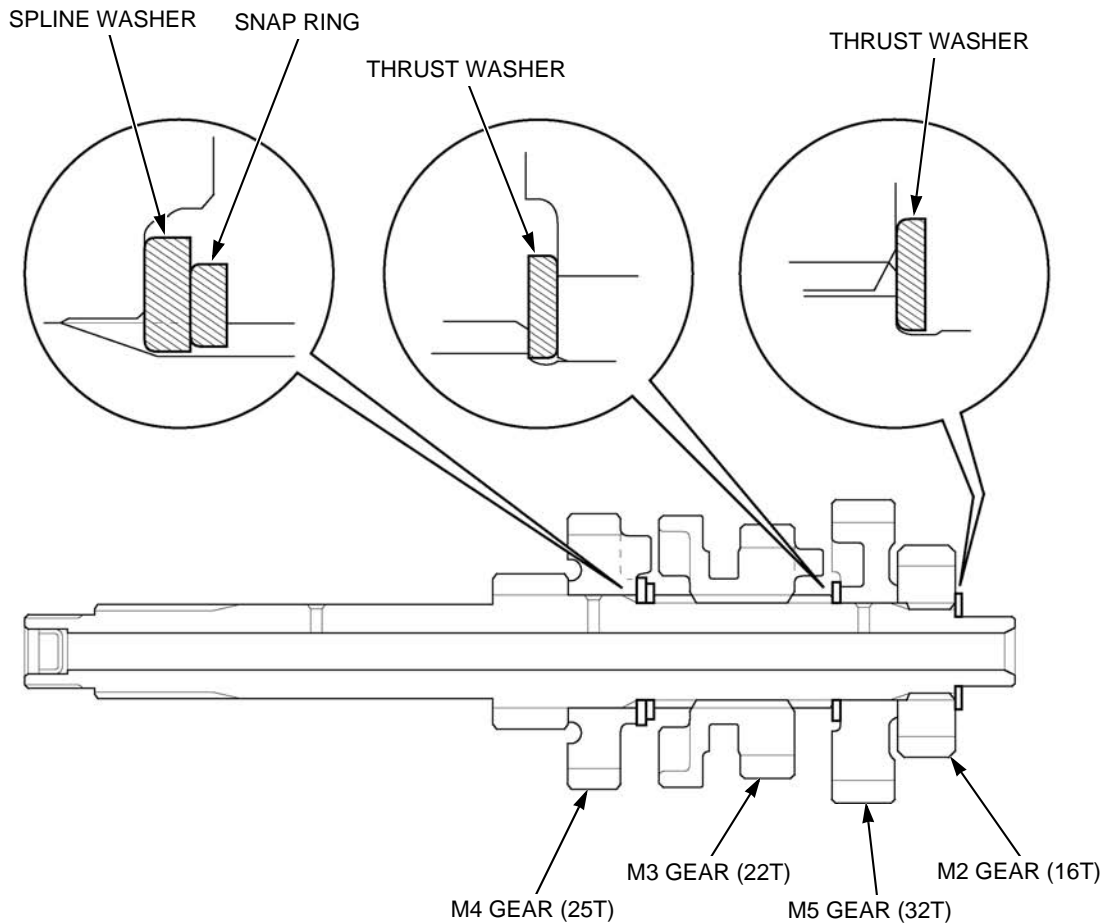
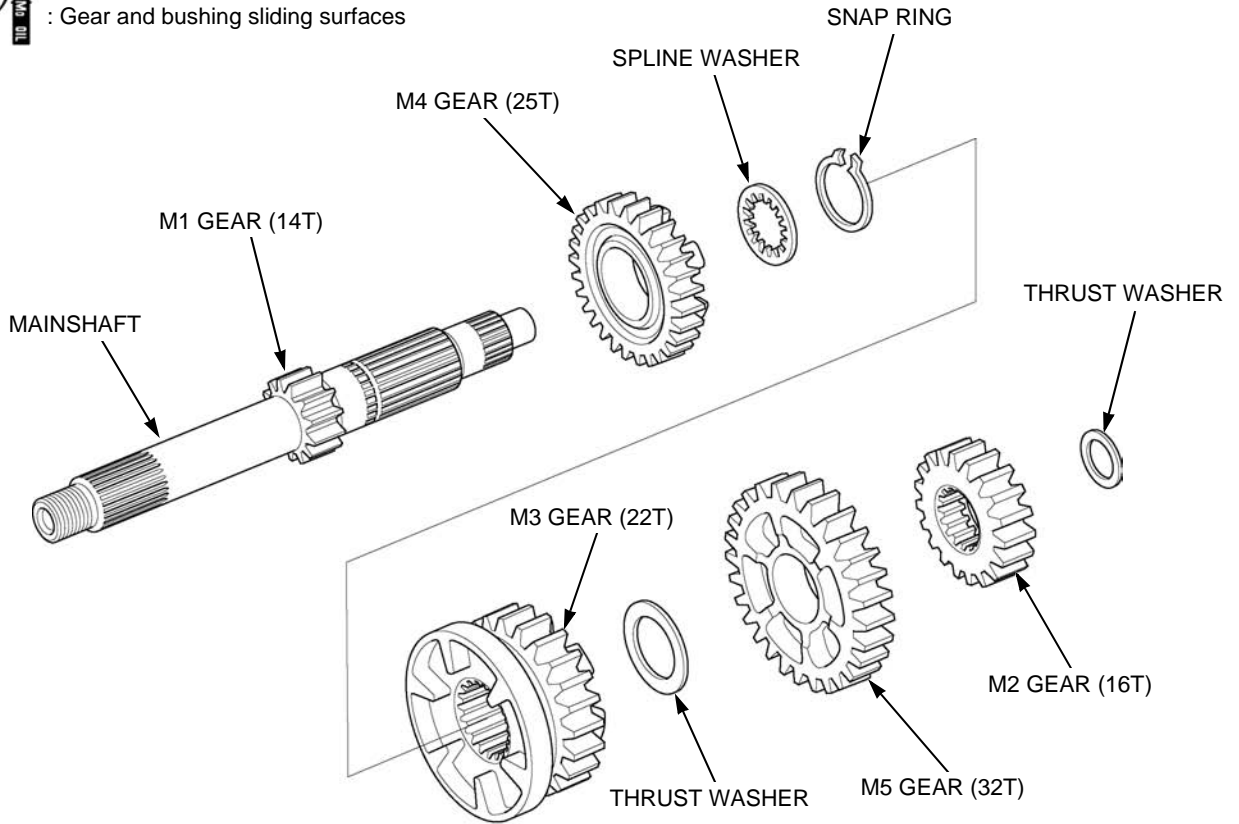

CRANKSHAFT/TRANSMISSION/KICKSTARTER

COUNTERSHAFT

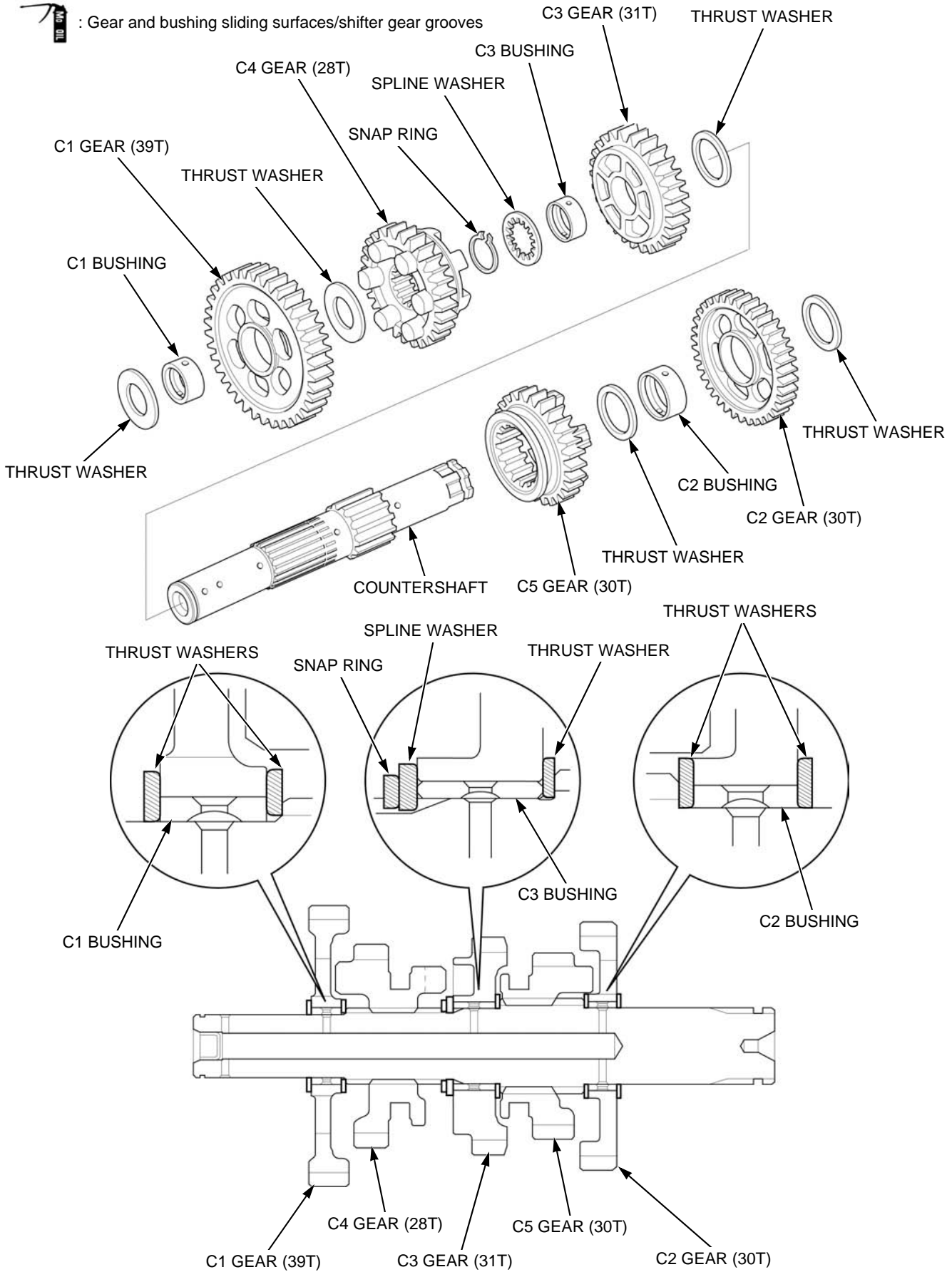

CRANKSHAFT/TRANSMISSION/KICKSTARTER

Apply molybdenum oil solution to the gear shifter grooves.

Apply clean engine oil to the gear teeth and engage the mainshaft and countershaft gears.

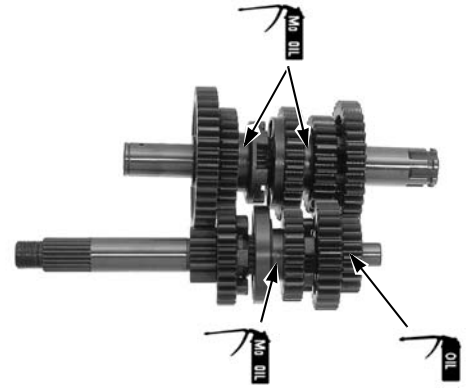

Install the mainshaft [1] and countershaft [2] assemblies as a set into the left crankcase.

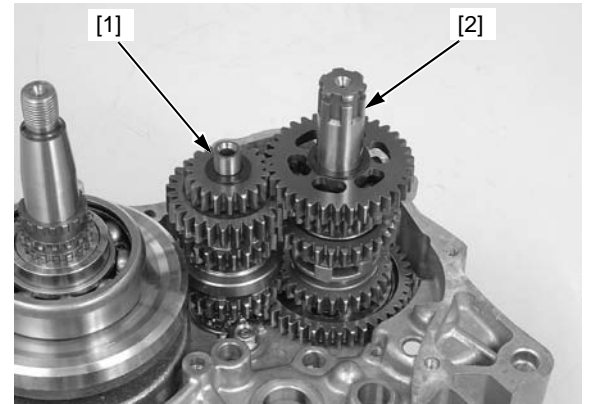

Each shift fork has an identification marks; "R/L" marks [1] for right and left shift forks, and "C" mark [2] for center shift fork.

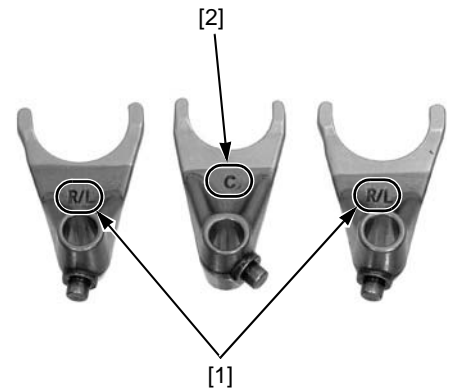

Install the shift forks [1] into the shifter gear grooves with the marks facing up (left crankcase side). Apply engine oil to the shift drum journals and guide grooves in the and install the shift drum [2]. Install the shift fork guide pins into the shift drum guide grooves.

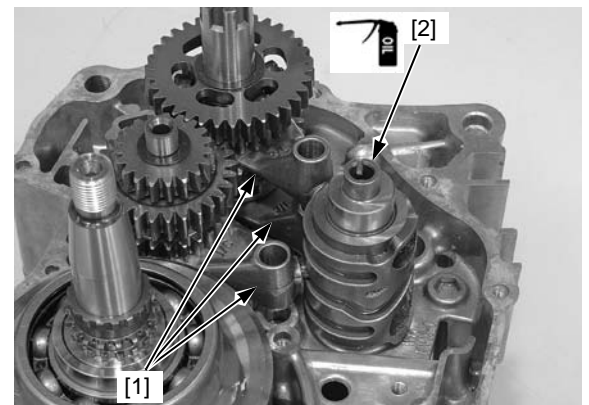

CRANKSHAFT/TRANSMISSION/KICKSTARTER

Apply engine oil to the shift fork shafts [1] and insert them through the shift forks into the right crankcase.

Assemble the crankcase (page 12-4).

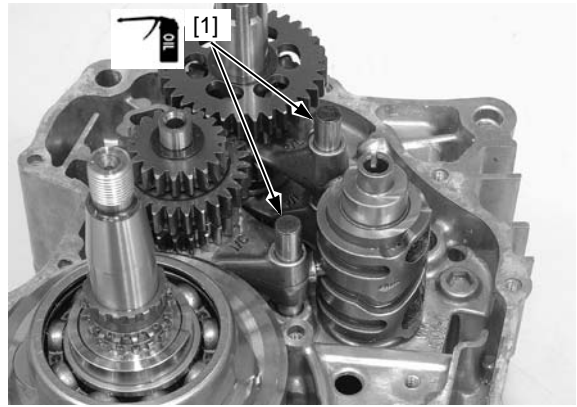

TRANSMISSION BEARING REPLACEMENT

RIGHT CRANKCASE

Remove the bolts [1] and mainshaft bearing setting plates [2] from the crankcase.

Drive the mainshaft bearing [3] and countershaft bearing [4] out of the crankcase.

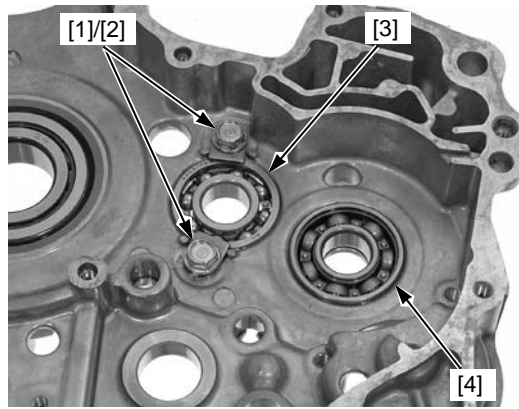

Apply engine oil to rolling area of new mainshaft bearing [1] and countershaft bearing.

Drive the bearings in the crankcase with the marked side facing up, using the special tools.

TOOLS:

[2] Driver	07749-0010000
[3] Attachment, 37 x 40 mm (mainshaft side)	07746-0010200
Attachment, 42 x 47 mm (countershaft side)	07746-0010300
[4] Pilot, 17 mm	07746-0040400

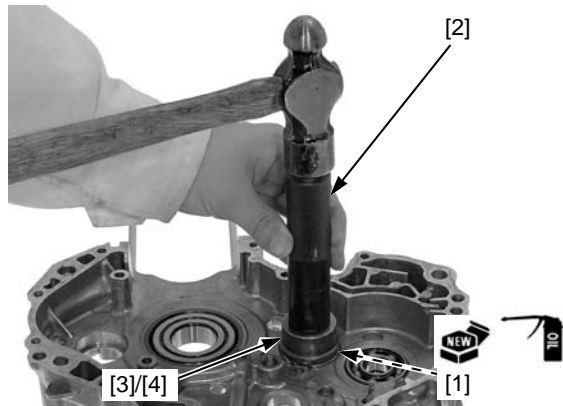

Apply locking agent to the setting plate bolt threads. Install the mainshaft bearing setting plates [1] and bolts [2], and tighten the bolts.

TORQUE: 12 N·m (1.2 kgf·m, 9 lbf·ft)

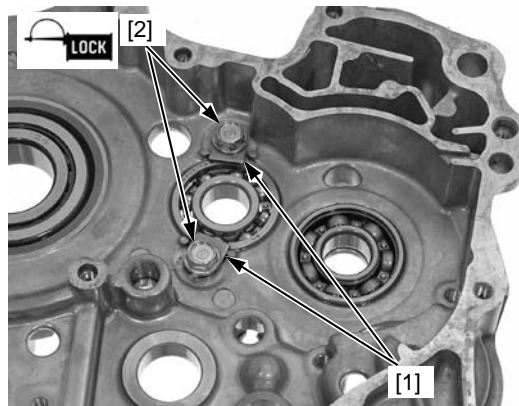

LEFT CRANKCASE BEARING REPLACEMENT

Drive the countershaft bearing [1] out of the crankcase.
 Remove the mainshaft bearing [2] from the crankcase using the special tools.

- TOOLS:**
 [3] Remover head, 12 mm 07936-1660110
 Remover shaft, 12 mm 07936-1660120
 Remover weight 07741-0010201

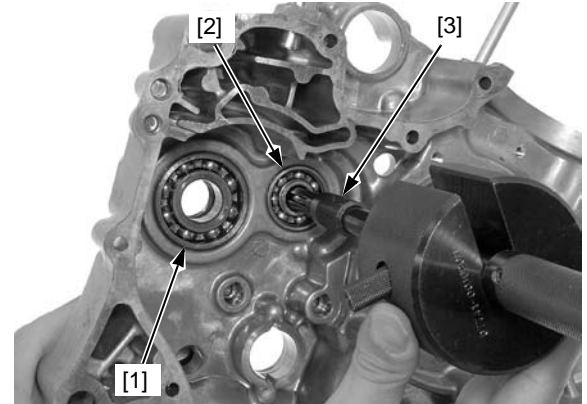

Apply engine oil to new bearings [1].
 Drive the bearings in the crankcase with the marked side facing up, using the special tools.

- TOOLS:**
Mainshaft bearing:
 [2] Driver 07749-0010000
 [3] Attachment, 32 x 35 mm 07746-0010100
 [4] Pilot, 12 mm 07746-0040200
Countershaft bearing:
 Driver 07749-0010000
 Attachment, 42 x 47 mm 07746-0010300
 Pilot, 20 mm 07746-0040500

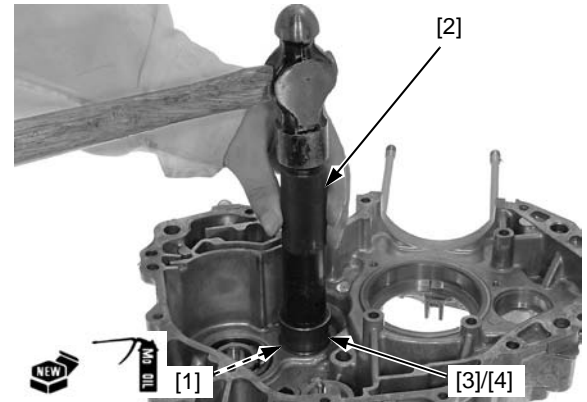

CRANKSHAFT

REMOVAL/INSTALLATION

Remove the crankshaft from the right crankcase.
 Apply 1 - 2 cm³ of molybdenum oil solution to the connecting rod big end bearing.
 Install the crankshaft [1] into the right crankcase.

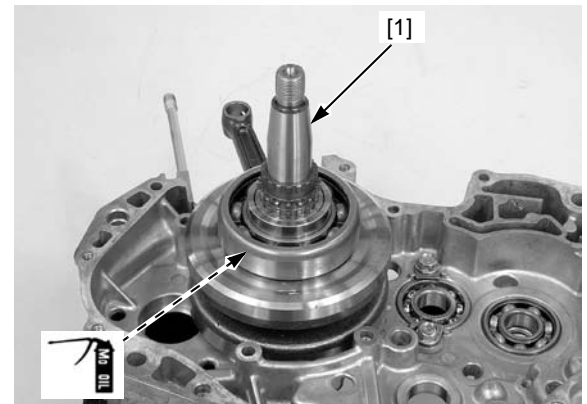

CRANKSHAFT BEARING REPLACEMENT

Remove the crankcase bearing inner race [1].
 Press the crankshaft bearing [2] out of the crankcase.

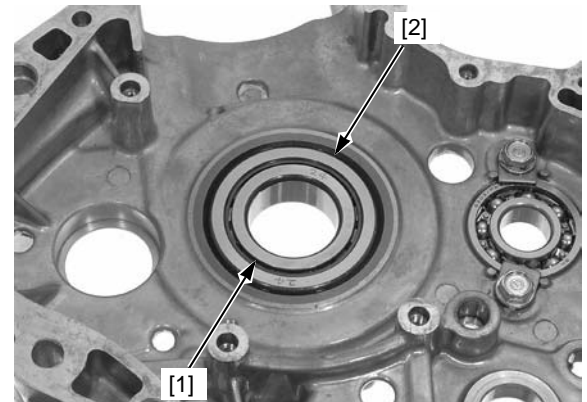

CRANKSHAFT/TRANSMISSION/KICKSTARTER

Lubricate a new crankcase bearing [1] with molybdenum oil solution.

Press the crankcase bearing into the crankcase using the special tools.

TOOLS:

[2] Driver	07749-0010000
[3] Attachment, 52 x 55 mm	07746-0010400
[4] Pilot, 30 mm	07746-0040700

Install a new crankcase bearing inner race.

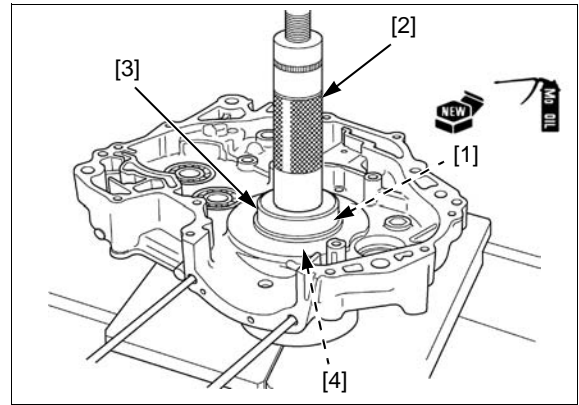

KICKSTARTER IDLE GEAR

REMOVAL

Remove the clutch assembly (page 10-7).

Remove the snap ring [1], washer [2] and kickstarter idle gear [3].

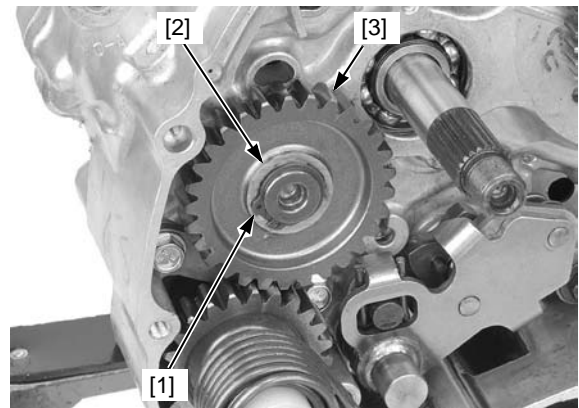

Remove the bushing [1] and washer [2].

INSTALLATION

Apply molybdenum oil solution to the bushing.

Install the washer and bushing.

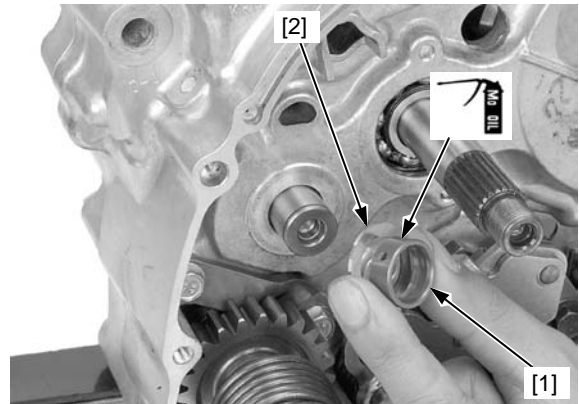

Apply engine oil to the kickstarter idle gear teeth.

Install the idle gear [1], washer [2] and snap ring [3].

Install the clutch assembly (page 10-8).

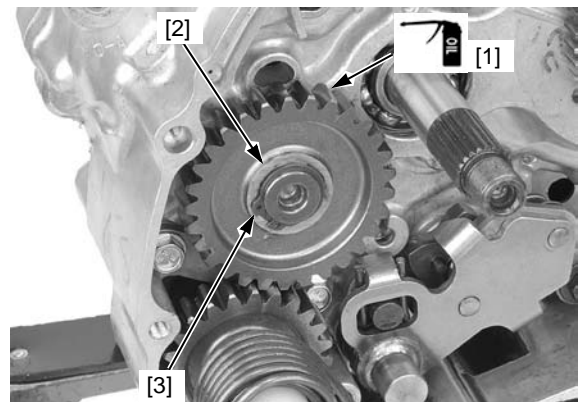

KICKSTARTER

REMOVAL

Remove the right crankcase cover (page 10-4).
 Unhook the return spring [1] from the crankcase.

Remove the following:

- Kickstarter assembly [1]
- Ratchet spring [2]
- Washer [3]

INSTALLATION

Apply engine oil to the kickstarter drive gear teeth.
 Install the ratchet spring and washer to the spindle.
 Install the kickstarter assembly.

Hook the return spring [1] to the crankcase.
 Install the right crankcase cover (page 10-4).

DISASSEMBLY

Remove the following:

- Collar [1]
- Return spring [2]
- Starter ratchet gear [3]

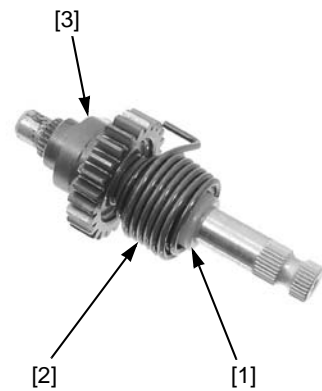
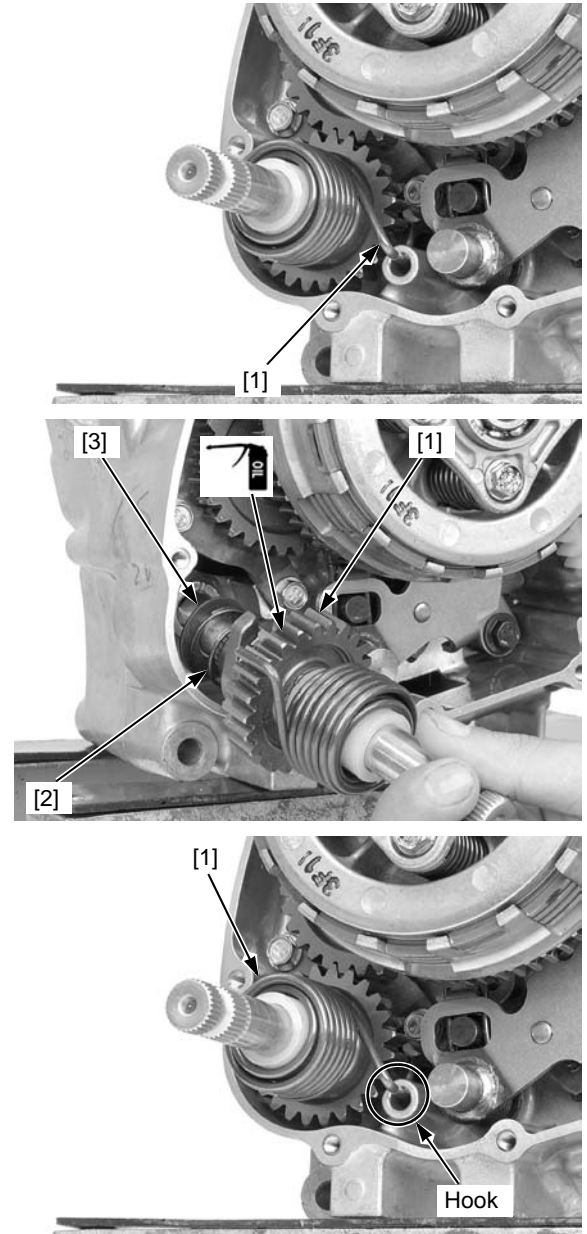

CRANKSHAFT/TRANSMISSION/KICKSTARTER

Remove the following:

- Snap ring [1]
- Washer A [2]
- Kickstarter drive gear [3]
- Washer B [4]

ASSEMBLY

Install the following:

- Washer B
- Kickstarter drive gear
- Washer A
- Snap ring

Install the ratchet gear [1].

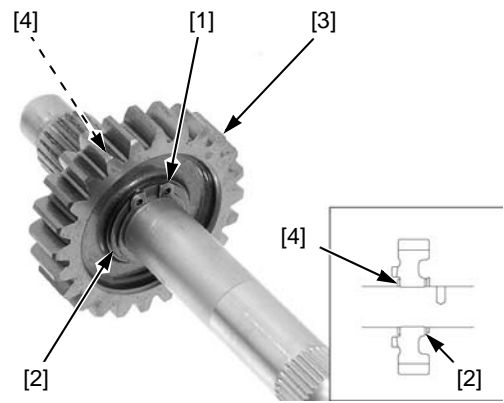

Hook the return spring [1] to the hole of the spindle.

Install the collar [2] to the return spring, aligning the cut-out of the collar with the spring.

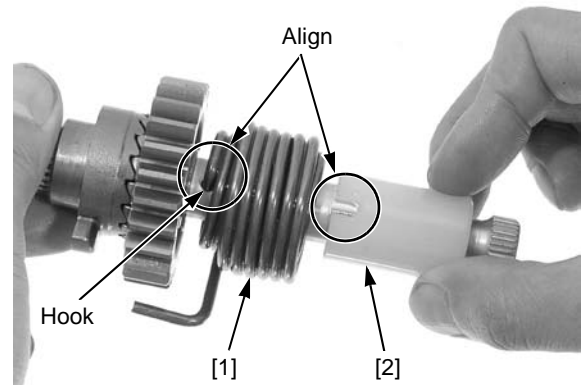

13. ENGINE REMOVAL/INSTALLATION

SYSTEM COMPONENTS.....	13-2	ENGINE REMOVAL	13-3
SERVICE INFORMATION	13-2	ENGINE INSTALLATION.....	13-5

ENGINE REMOVAL/INSTALLATION

SYSTEM COMPONENTS

XR125LK/LEK shown:

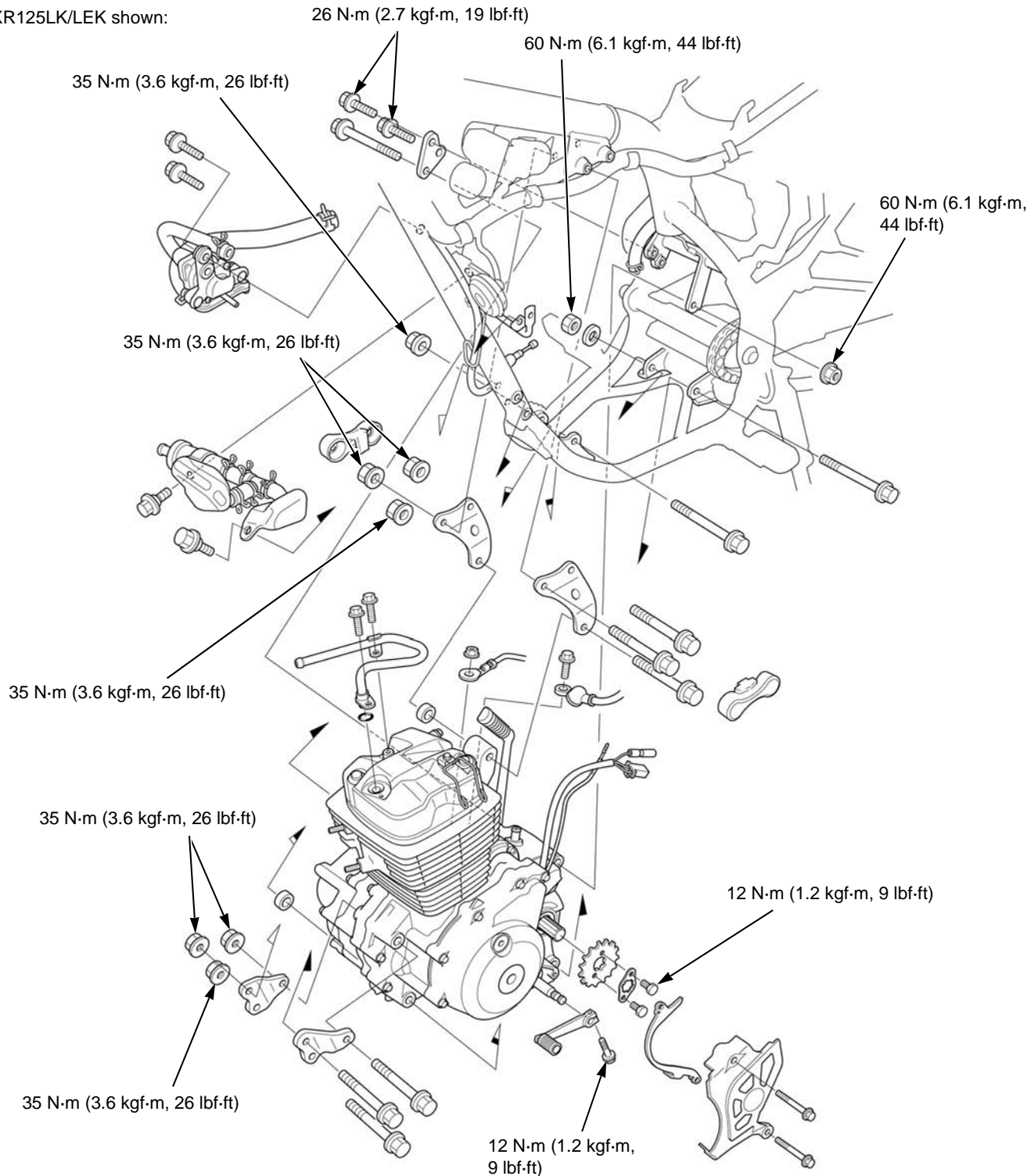

SERVICE INFORMATION

GENERAL

- A floor jack or other adjustable support is required to support and maneuver the engine.
- When removing/installing the engine, tape the frame around the engine beforehand for frame protection.
- The following components require engine removal for service.
 - Crankshaft (page 12-13)
 - Transmission (page 12-8)

ENGINE REMOVAL

Drain the engine oil (page 3-7).

Support the motorcycle securely using a hoist or workstand.

Loosen the drive chain (page 3-10).

Remove the following:

- Side covers (page 2-2)
- Fuel tank (page 2-4)
- Exhaust pipe (page 2-6)
- Carburetor (page 6-5)
- PAIR control valve (XR125LK/LEK) (page 6-14)
- Resonator tank/air inlet cover (XR125LK/LEK) (page 6-15)
- Spark plug cap
- Clutch cable (page 10-4)
- Pinch bolt [1]
- Gearshift pedal [2]
- Drive sprocket cover bolts [3]
- Drive sprocket cover [4]/drive chain guide [5]
- Fixing plate bolts [1]
- Fixing plate [2] (by aligning the splines of the plate and countershaft)
- Drive sprocket [3] (pull it off the countershaft and remove from the drive chain)

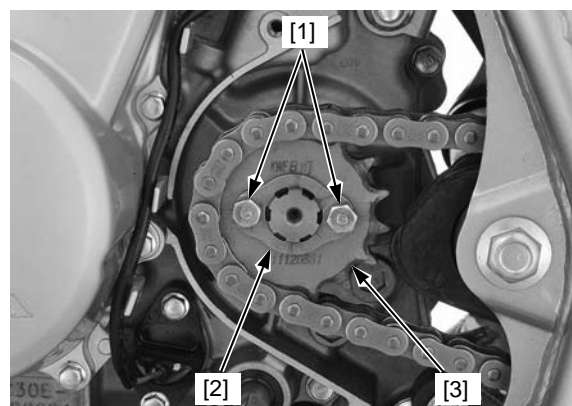
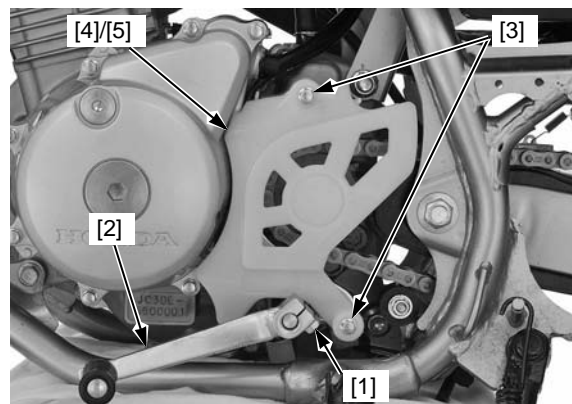

- Brake adjusting nut [1]
- Brake rod [2] (from the joint pin)
- Rod spring [3]
- Joint pin [4]

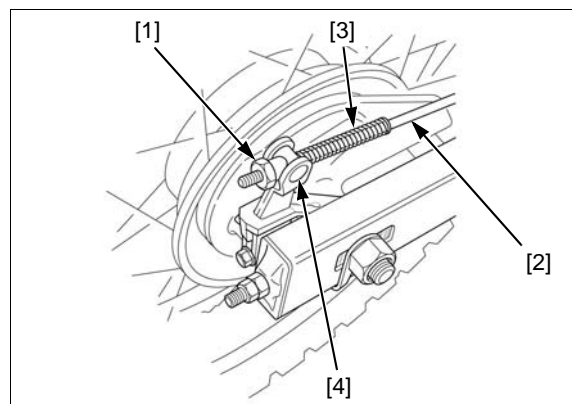

- Brake pedal return spring [1]



ENGINE REMOVAL/INSTALLATION

Disconnect the following:

- Alternator 2P connector [1]
- Ignition pulse generator wire connector [2]
- Neutral switch wire connector [3]



- Starter motor cable [1] (by removing the rubber cap [2] and terminal nut [3])
- Battery negative cable [4] (by removing the motor mounting bolt [5])

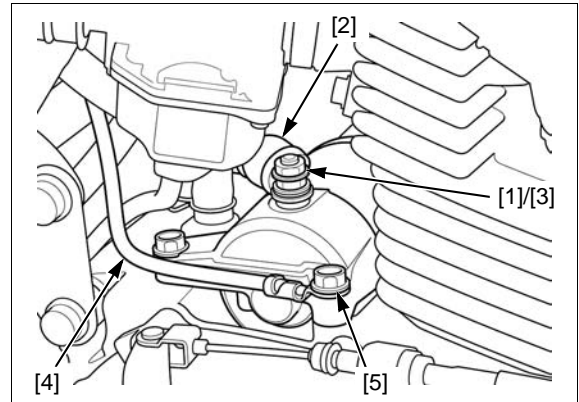

Remove the rubber caps [1] from the upper engine hanger plates.

Remove each engine hanger plate, hanger bolt and nut.

- Two upper engine hanger plate nuts [2], bolts [3]
- Upper engine hanger nut [4] and bolt [5]
- Hanger plates [6] and collar [7]

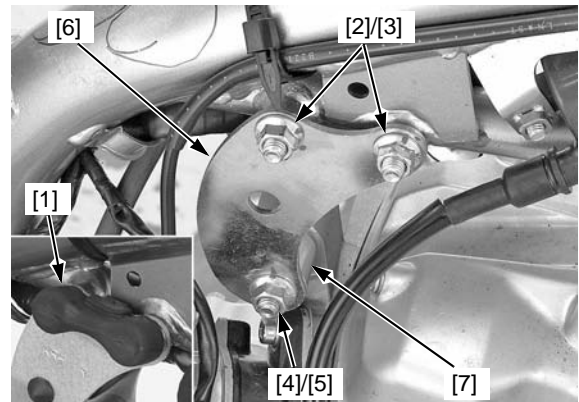

- Rear upper engine hanger nut [1] and bolt [2]
- Rear upper engine hanger plate bolts [3]
- Hanger plate [4]
- Crankcase breather hose [5]

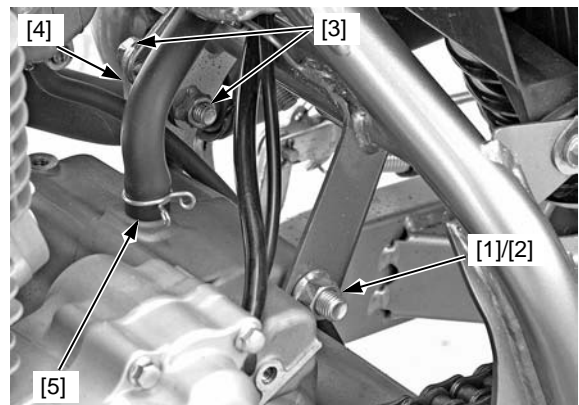

- Front upper engine hanger nut [1] and bolt [2]
- Front upper engine hanger plate nuts [3] and bolts [4]
- Hanger plates [5]
- Front lower engine hanger nut [6], bolt [7] and collar [8]
- Rear lower engine hanger nut [9], washer [10] and bolt [11]

During engine removal, hold the engine securely and be careful not to damage the frame and engine. Carefully maneuver the engine and remove it out of the frame to the right side.

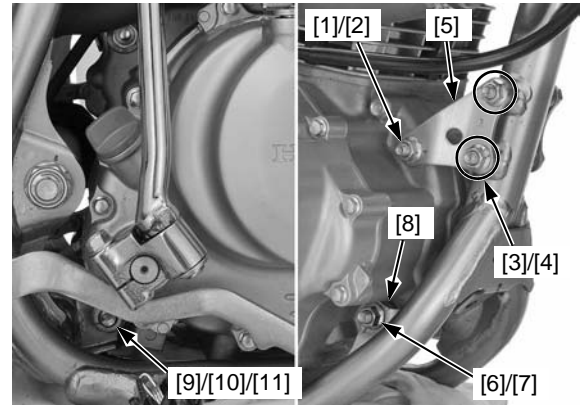

ENGINE INSTALLATION

NOTE:

- Use the correct bolts in their proper positions.
- Note the direction of the hanger bolts and the location of the collars (page 13-2).

XR125LK/LEK only:

- The hanger plates are identified by the marks. Install with the marked side facing out; "R": right / "L": left.

Using the floor jack or other adjustable support, carefully place the engine into the frame from the right side and maneuver it into place.

During engine installation, hold the engine securely and be careful not to damage the frame and engine. Carefully align the bolt holes in the frame and engine, then install all the engine hanger plates, hanger bolts and nuts.

After installing all the engine mounting fasteners, tighten them to the specified torque.

TORQUE:

- [1] Rear lower engine hanger bolt/nut**
60 N-m (6.1 kgf-m, 44 lbf-ft)
- [2] Front lower engine hanger bolt/nut**
35 N-m (3.6 kgf-m, 26 lbf-ft)
- [3] Front upper engine hanger plate bolts/nuts**
35 N-m (3.6 kgf-m, 26 lbf-ft)
- [4] Front upper engine hanger bolt/nut**
35 N-m (3.6 kgf-m, 26 lbf-ft)
- [5] Rear upper engine hanger plate bolts**
26 N-m (2.7 kgf-m, 19 lbf-ft)
- [6] Rear upper engine hanger bolt/nut**
60 N-m (6.1 kgf-m, 44 lbf-ft)
- [7] Upper engine hanger plate bolts/nuts**
35 N-m (3.6 kgf-m, 26 lbf-ft)
- [8] Upper engine hanger bolt/nut**
35 N-m (3.6 kgf-m, 26 lbf-ft)

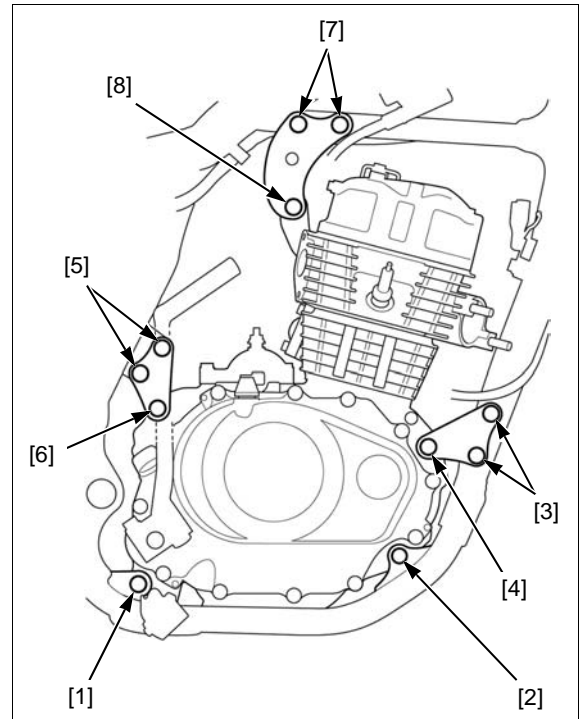

ENGINE REMOVAL/INSTALLATION

Hang the tab of each rubber caps [1] onto the hanger plate [2] and install them over the upper engine hanger plate bolts [3].

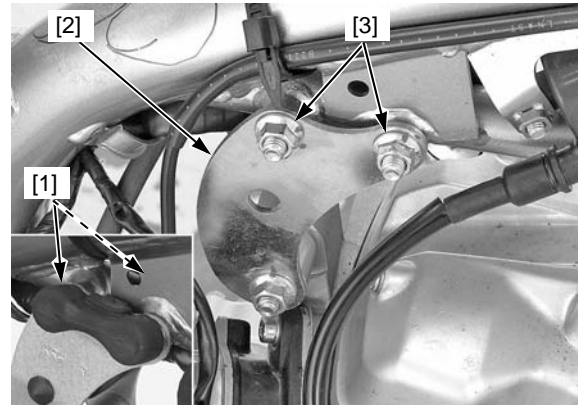

Install the drive chain onto the drive sprocket [1].

Install the drive sprocket onto the countershaft.

Install the fixing plate [2] to the countershaft while aligning their teeth.

Rotate the fixing plate and align the bolt holes.

Install and tighten the drive sprocket fixing plate bolts [3] alternately to the specified torque.

TORQUE: 12 N·m (1.2 kgf·m, 9 lbf·ft)

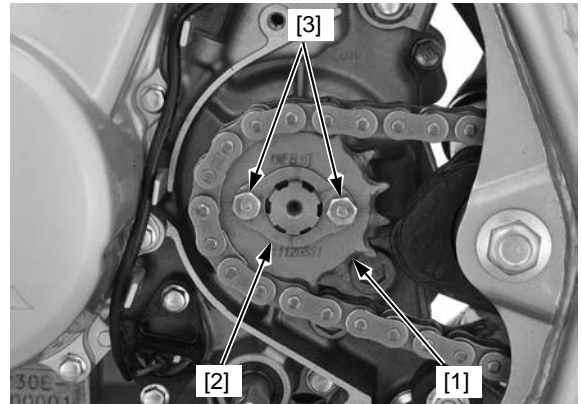

Install the gearshift pedal [1] on its original position as marked during removal.

Install and tighten the pinch bolt [2] to the specified torque.

TORQUE: 12 N·m (1.2 kgf·m, 9 lbf·ft)

Install the removed parts in the reverse order of removal.

Fill the crankcase with recommended engine oil (page 3-7).

Check the following:

- Clutch lever freeplay (page 3-15)
- Drive chain slack (page 3-10)
- Brake pedal freeplay (page 3-14)

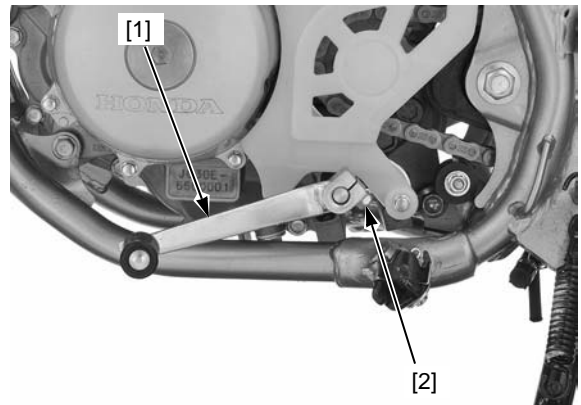

14. FRONT WHEEL/BRAKE/SUSPENSION/ STEERING

SYSTEM COMPONENTS.....	14-2	FRONT WHEEL	14-9
SERVICE INFORMATION	14-3	FRONT DRUM BRAKE (XL125LK)	14-13
TROUBLESHOOTING.....	14-3	FORK.....	14-13
HANDLEBAR	14-4	STEERING STEM	14-22

FRONT WHEEL/BRAKE/SUSPENSION/STEERING

SYSTEM COMPONENTS

XR125LK/LEK:

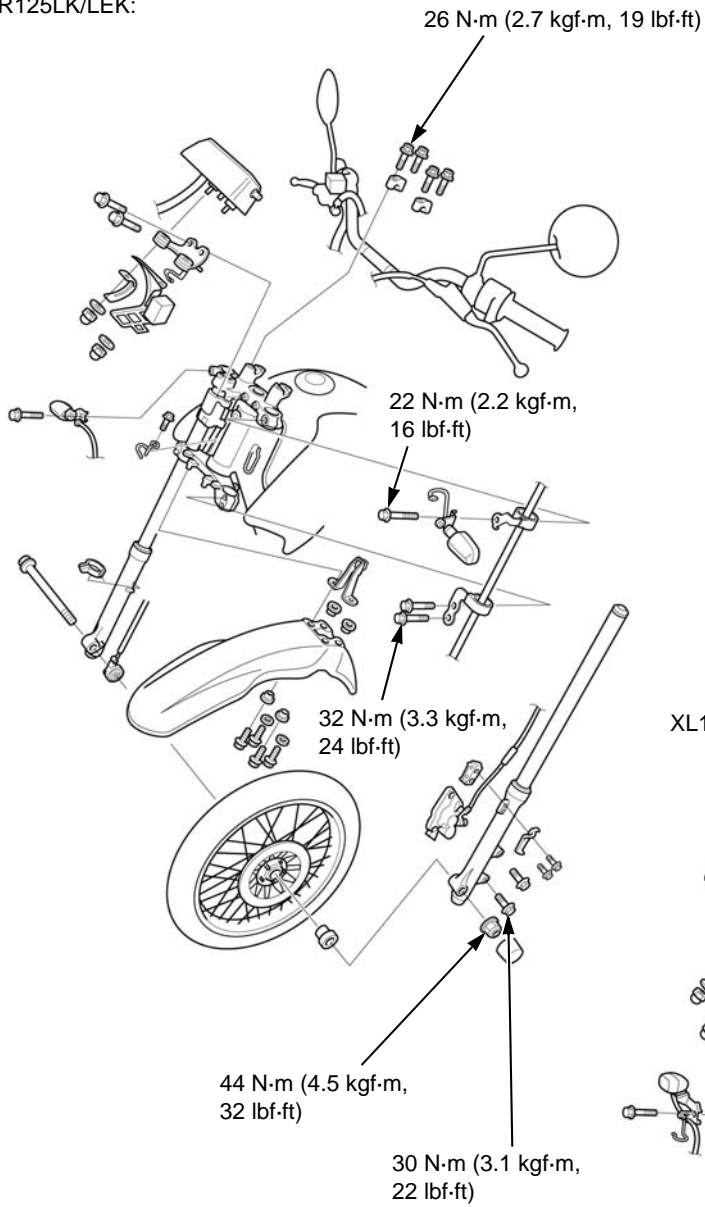

XL125LK:

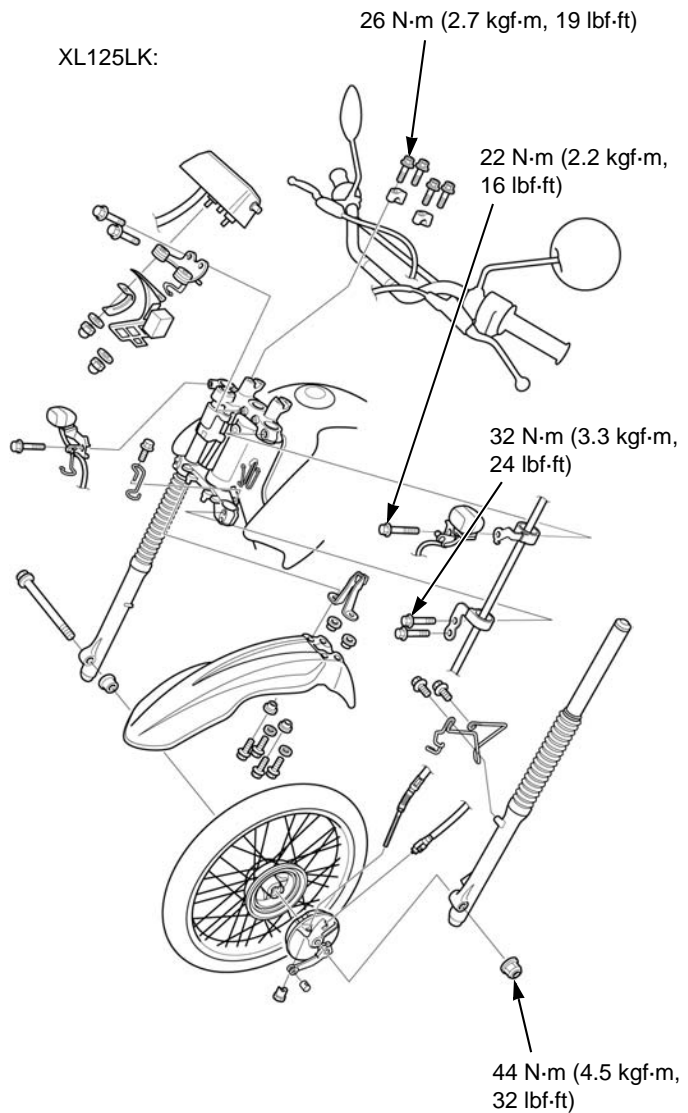

SERVICE INFORMATION

GENERAL

⚠ WARNING

Frequent inhalation of brake shoe or pad dust, regardless of material composition could be hazardous to your health.

- Avoid breathing dust particles.
- Never use an air hose or brush to clean brake assemblies. Use an OSHA-approved vacuum cleaner.

- When servicing the front wheel, fork or steering stem, support the motorcycle using a safety stand or hoist.
- A contaminated brake disc or pad (drum or shoe) reduces stopping power. Discard contaminated pads (shoes) and clean a contaminated disc (drum) with a high quality brake degreasing agent.
- After the front wheel installation, check the brake operation by applying the brake lever and pedal.
- Refer to procedure for hydraulic brake system servicing (page 16-3).

TROUBLESHOOTING

Hard steering

- Steering top thread too tight
- Faulty steering head bearings
- Damaged steering head bearings
- Faulty tire
- Insufficient tire pressure

Steers to one side or does not track straight

- Bent fork
- Faulty steering head bearings
- Damaged steering head bearings
- Bent frame
- Worn wheel bearings
- Bent front axle
- Worn swingarm pivot component

Front wheel wobbling

- Bent rim
- Worn wheel bearings
- Faulty tire
- Unbalanced tire and wheel

Soft suspension

- Weak fork spring
- Low fluid level in fork
- Insufficient fluid in fork
- Low tire pressure

Hard suspension

- High tire pressure
- Bent fork
- High fluid level in fork
- Incorrect fluid weight
- Clogged fluid passage

Front suspension noise

- Loose fork fasteners
- Insufficient fluid in fork

Wheel turns hard

- Faulty wheel bearings
- Bent front axle
- Brake drag
- Faulty speedometer gear

Poor front brake performance (XL125LK)

- Improper brake adjustment
- Worn brake linings
- Contaminated brake linings
- Worn brake cam
- Worn brake drum
- Brake arm serrations improperly engaged
- Worn brake shoes at cam contact faces

FRONT WHEEL/BRAKE/SUSPENSION/STEERING

HANDLEBAR

REMOVAL

Remove the wire bands [1].
Remove the rearview mirrors [2].

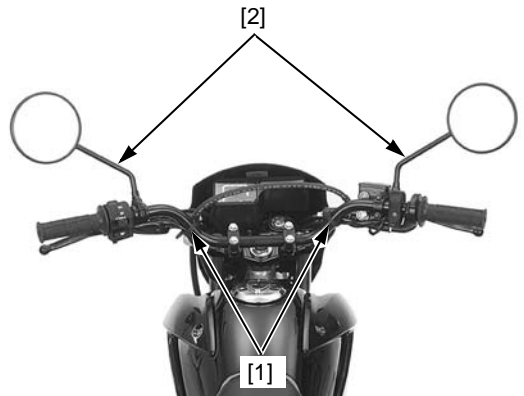

Remove the front visor [2] (page 2-4).

XR125LK/LEK: Disconnect the front brake light switch connectors [1].

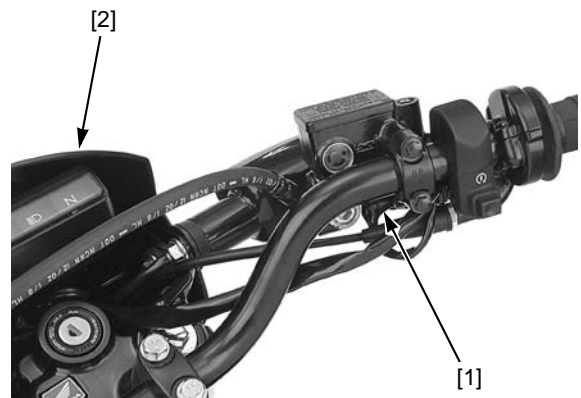

XR125LK/LEK: Remove the bolts [1], master cylinder holder [2] and master cylinder [3].

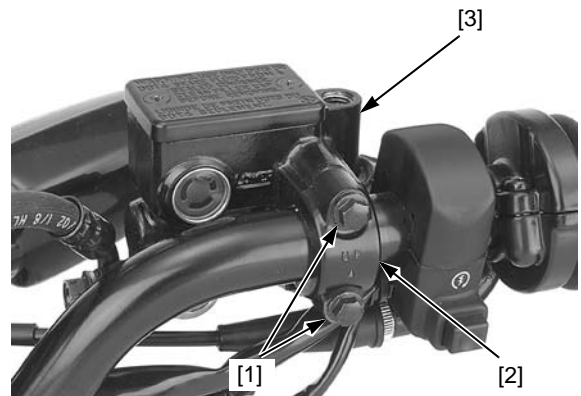

XL125LK: Remove the bolts [1], holder [2] and brake lever bracket [3].

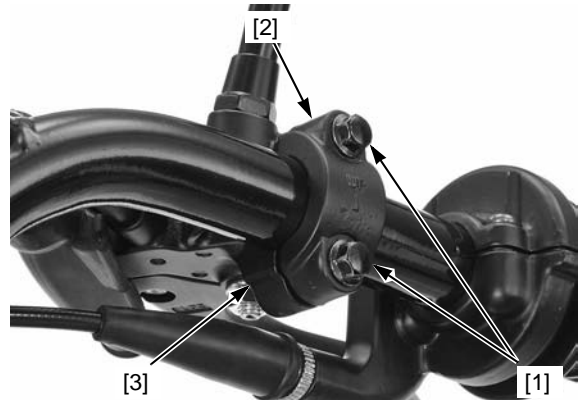

FRONT WHEEL/BRAKE/SUSPENSION/STEERING

Remove the screws [1] and throttle housing cover [2].
Disconnect the throttle cable end [3] from the throttle pipe and remove the throttle housing.
Remove the throttle cable guide [4].
Remove the throttle grip from the handlebar.

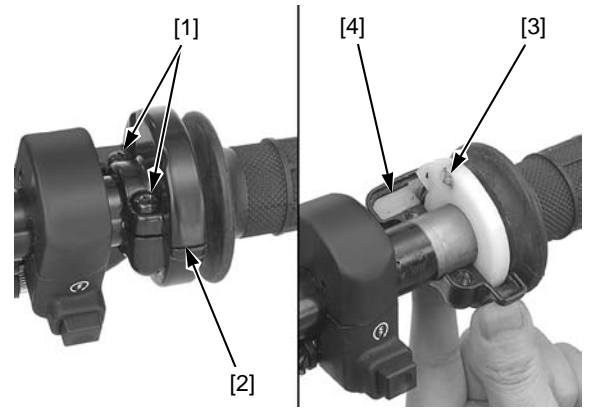

Remove the right handlebar switch housing screws [1].
Remove the right handlebar switch housing [2] from the handlebar.

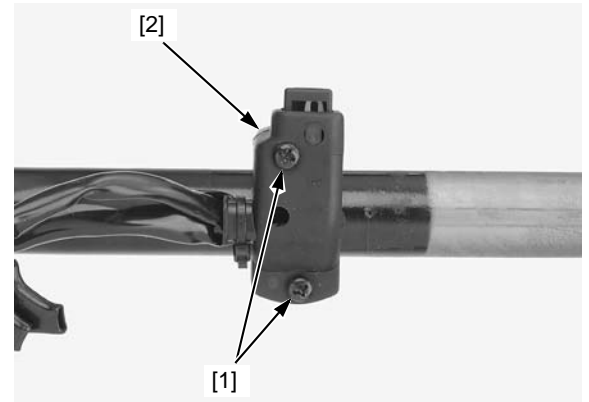

Disconnect the clutch switch connectors [1] from the clutch switch.

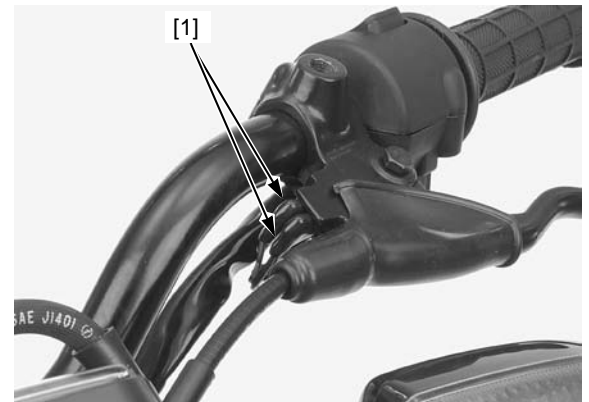

Remove the clutch lever holder screws [1], bracket [2] and holder [3].

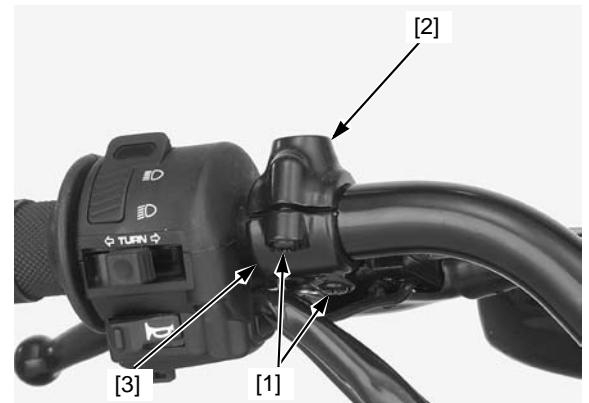

FRONT WHEEL/BRAKE/SUSPENSION/STEERING

Remove the left handlebar switch housing screws [1].
Remove the left handlebar switch housing [2] from the handlebar.

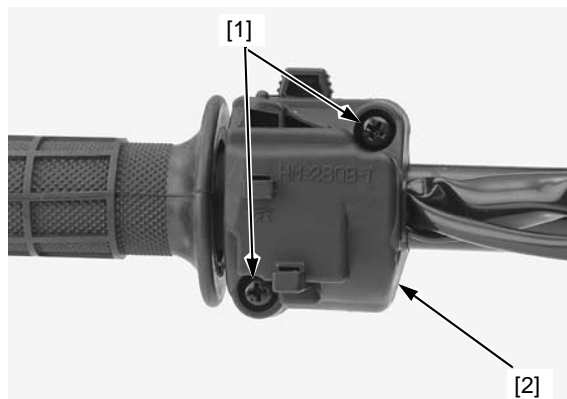

Remove the handlebar holder bolts [1] and holders [2].
Remove the handlebar [3].

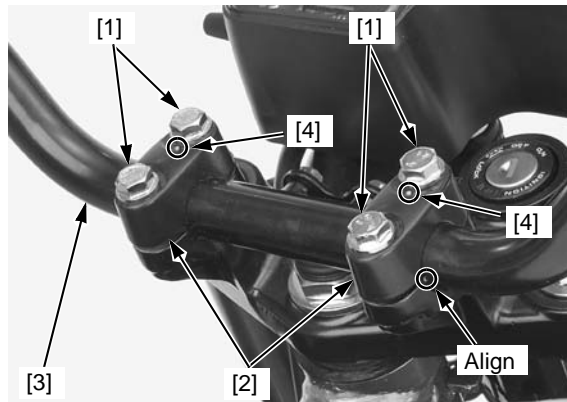

INSTALLATION

Place the handlebar onto the lower holders by aligning the punch mark on the handlebar with the mating surface of the lower holder.

Place the upper holders with the punch marks [4] facing forward.

Install the handlebar holder bolts and tighten the front bolts first, then the rear bolts.

TORQUE: 26 N-m (2.7 kgf-m, 19 lbf-ft)

Allow the adhesive to dry for an hour before using.

Apply Honda Bond A [1] or an equivalent to the inside of the grip [2] and the clean surfaces of the left handlebar and throttle grip.

Wait 3-5 minutes to install the grip.

Rotate the grip to spread the adhesive evenly.

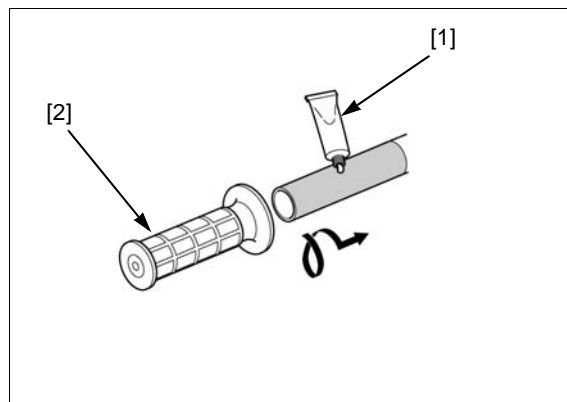

Install the left handlebar switch housing [1] onto the handlebar by aligning the locating pin [2] with the hole [3] in the handlebar.

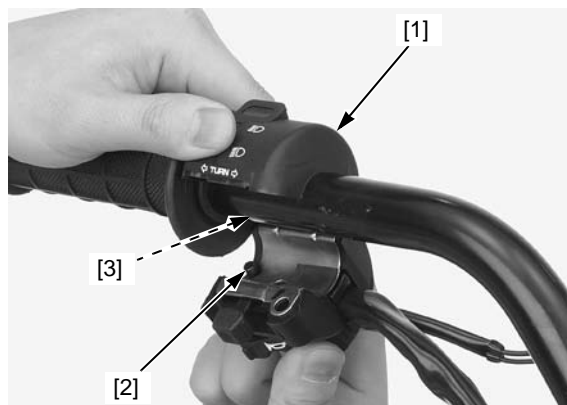

FRONT WHEEL/BRAKE/SUSPENSION/STEERING

Install the left handlebar switch housing screws [1] and tighten the forward screw first, then the rear screw.

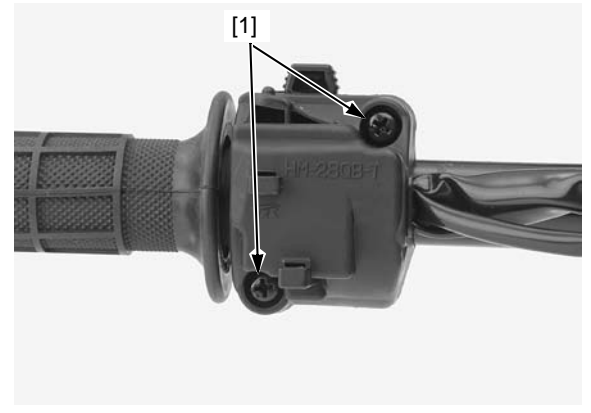

Install the clutch lever bracket [1] and holder [2] to the handlebar.
Align the slit of the bracket with the punch mark [3] on the handlebar.
Install the clutch lever holder screws [4], and tighten the forward screw first, then rear screw.

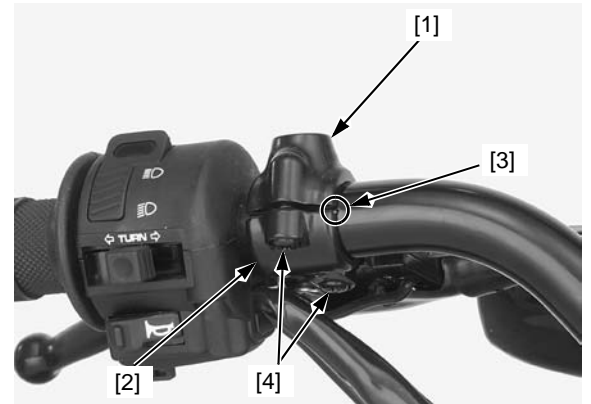

Connect the clutch switch connectors [1] to the clutch switch.

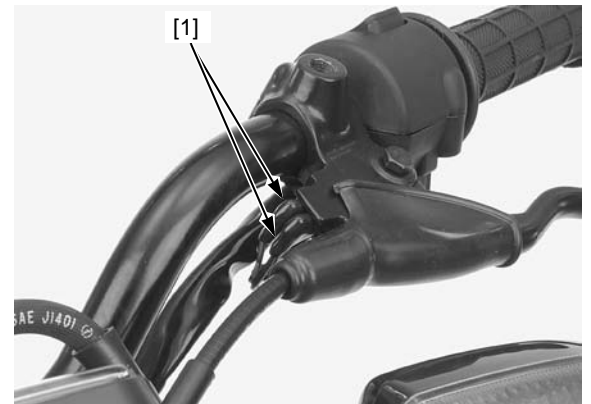

Install the right handlebar switch housing [1] by aligning its locating pin [2] with the hole [3] in the handlebar.

Install the right handlebar switch housing screws [4], and tighten the forward screw first, then the rear screw.

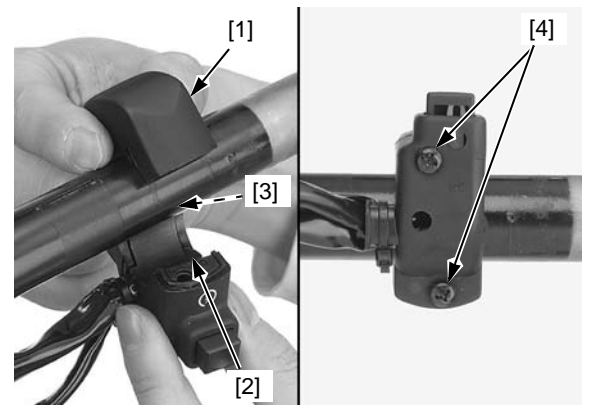

FRONT WHEEL/BRAKE/SUSPENSION/STEERING

Apply grease to the throttle cable contact point.

Install the throttle grip [1] to the handlebar.

Install the throttle housing [2].

Apply grease to the throttle cable end [3].

Connect the throttle cable to the throttle pipe.

Apply grease to the throttle cable guide [4].

Install the throttle cable guide into the throttle housing.

Install the throttle housing cover [5].

Align the slit of the throttle housing and cover with the punch mark [6] on the handlebar.

Install the throttle housing cover screws [7], and tighten the forward screw first, then the rear screw.

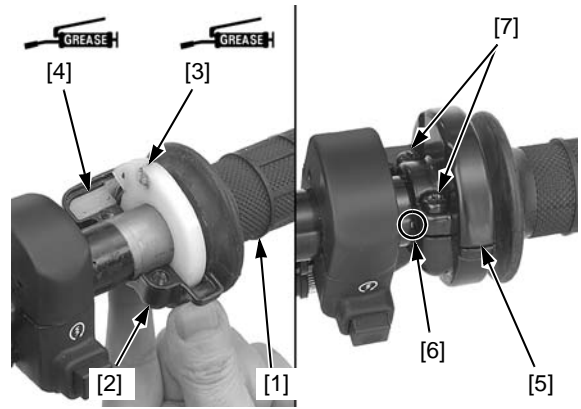

XR125LK/LEK: Install the master cylinder [1] and holder [2] with the "UP" mark [3] on the holder facing up.

Install the master cylinder holder bolts [4].

Align the end of the master cylinder with the punch mark [5] on the handlebar, and tighten the upper bolt first, then lower bolt.

TORQUE: 12 N·m (1.2 kgf·m, 9 lbf·ft)

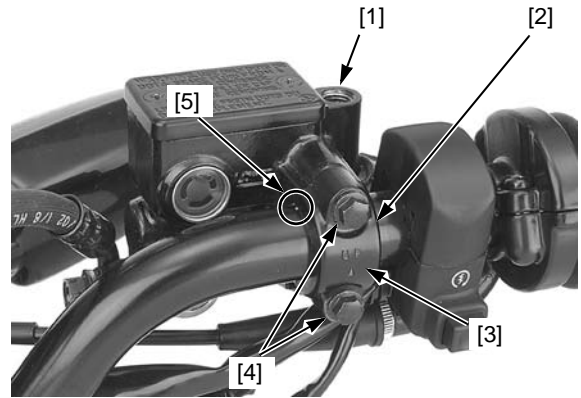

XL125LK: Install the brake lever bracket [1] and holder [2] with the "UP" mark [3] on the holder facing up.

Install the holder bolts [4].

Align the end of the brake lever bracket with the punch mark [5] on the handlebar, and tighten the upper bolt first, then lower bolt.

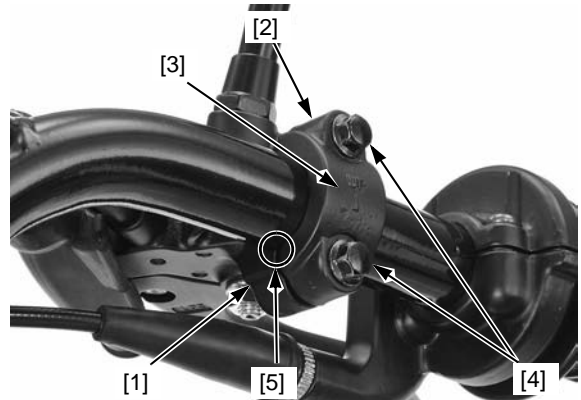

Install the front visor [2] (page 2-4).

XR125LK/LEK: Connect the front brake light switch connectors [1].

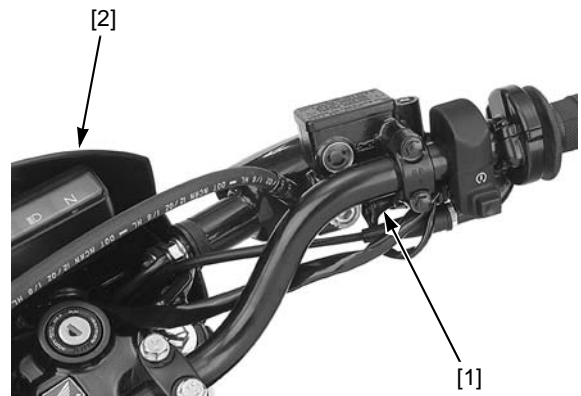

Install the wire bands [1].
Install the rearview mirrors [2].

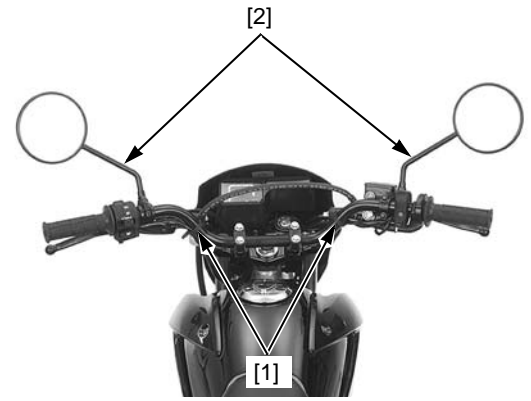

FRONT WHEEL

REMOVAL (XR125LK/LEK)

Do not operate the front brake lever after removing the front wheel. To do so will cause difficulty in fitting the brake disc between the brake pads.

Raise and support the motorcycle using safety stand or a hoist.
Remove the screw [1] and speedometer cable [2] from the speedometer gear box.

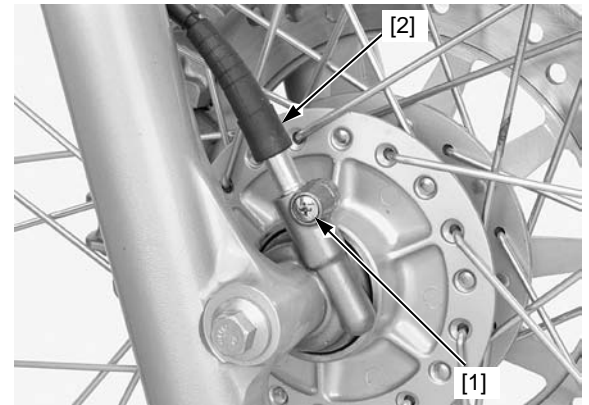

Remove the rubber cap.
Remove the axle nut [1] and pull out the axle [2].
Remove the front wheel.

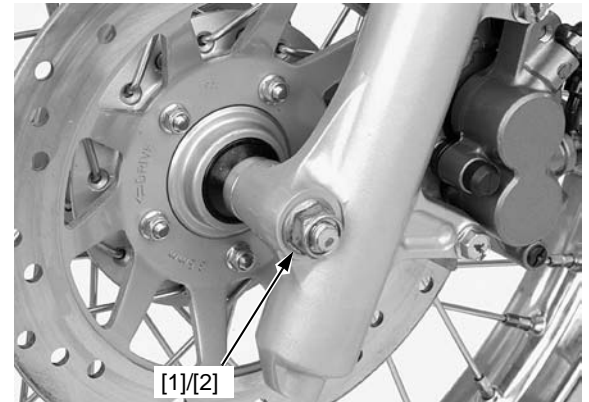

Remove the speedometer gear box [1] and side collar [2].

INSTALLATION (XR125LK/LEK)

Install the side collar and speedometer gear box.



FRONT WHEEL/BRAKE/SUSPENSION/STEERING

Install the wheel assembly onto the fork legs so that the brake disc is positioned between the pads, being careful not to damage the pads.

Align the groove on the speedometer gear box with the lug on the right fork leg as shown.

Install the front axle [1] from the right side.

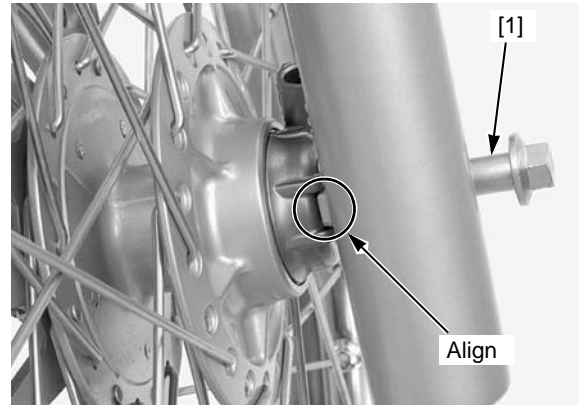

Install and tighten the front axle nut [1] to the specified torque.

TORQUE: 44 N·m (4.5 kgf·m, 32 lbf·ft)

Install the rubber cap [2] to the axle nut.

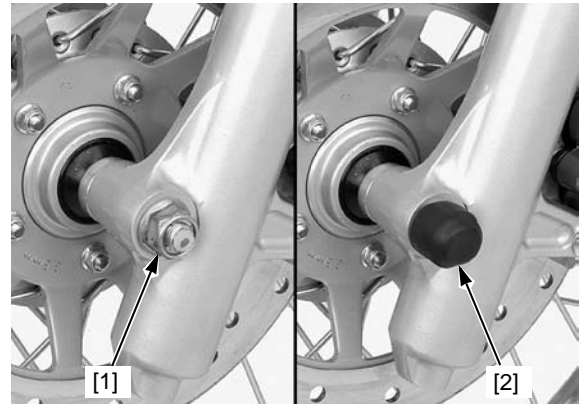

Connect the speedometer cable [1] to the gear box and secure it with the set screw [2].

With the front brake applied, pump the fork up and down several times to seat the axle and check the front brake operation.

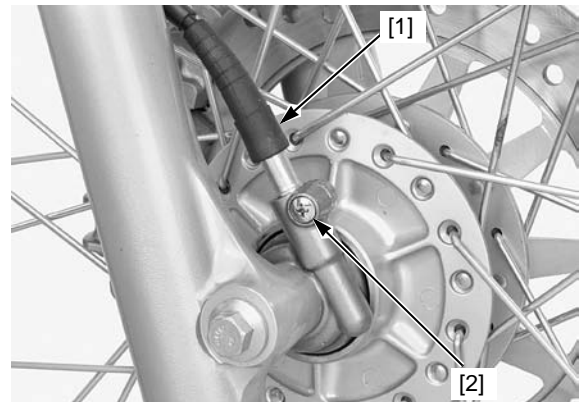

REMOVAL (XL125LK)

Raise and support the motorcycle using safety stand or a hoist.

Release the tab [1] while pushing it and disconnect the speedometer cable [2].

Remove the adjusting nut [3] and joint pin [4], and disconnect the brake cable [5] from the brake panel.

Remove the axle nut [6] and pull out the axle [7].

Remove the front wheel.

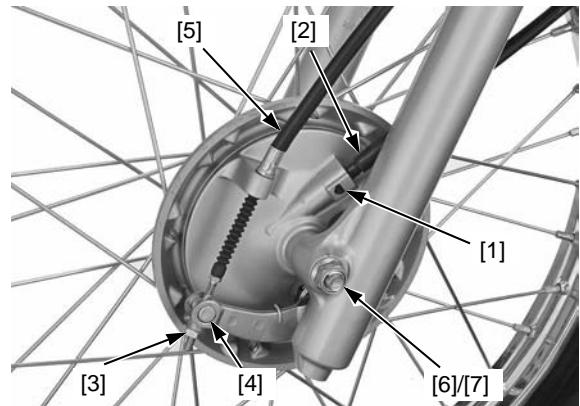

Remove the brake panel [1] and side collar [2].

INSTALLATION (XL125LK)

Install the side collar.

Install the brake panel while aligning the speedometer gear tabs [3] with the grooves [4] on the hub.

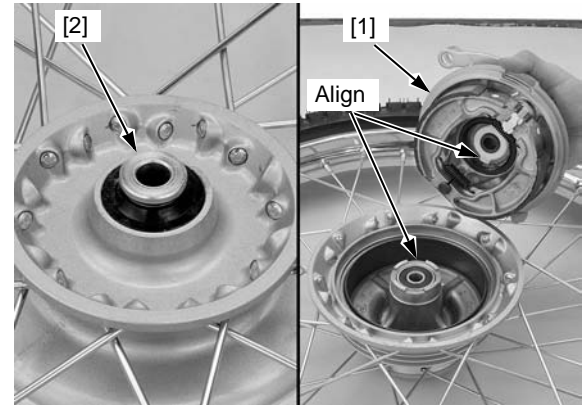

Install the front wheel by aligning the groove on the brake panel with the lug on the left fork leg. Install the front axle [1] from the right side. Install the axle nut [2] and tighten it to the specified torque.

TORQUE: 44 N-m (4.5 kgf-m, 32 lbf-ft)

Install the brake cable [3] into the brake panel and connect it with the joint pin [4] and adjusting nut [5]. Connect the speedometer cable [6].

Adjust the front brake lever freeplay and check the brake operation (page 3-13).

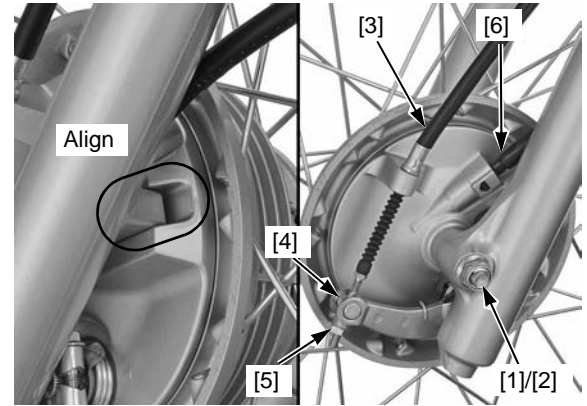

DISASSEMBLY/ASSEMBLY

XR125LK/LEK:

Remove/install the following:

- Dust seals [1]
- Retainer [2]
- Nuts [3]
- Brake disc [4]
- Wheel bearings [5]
- Distance collar [6]

- Replace the bearings and dust seals with new ones.
- Apply grease to the dust seal lips.

Refer to procedures for wheel bearing replacement (page 14-12).

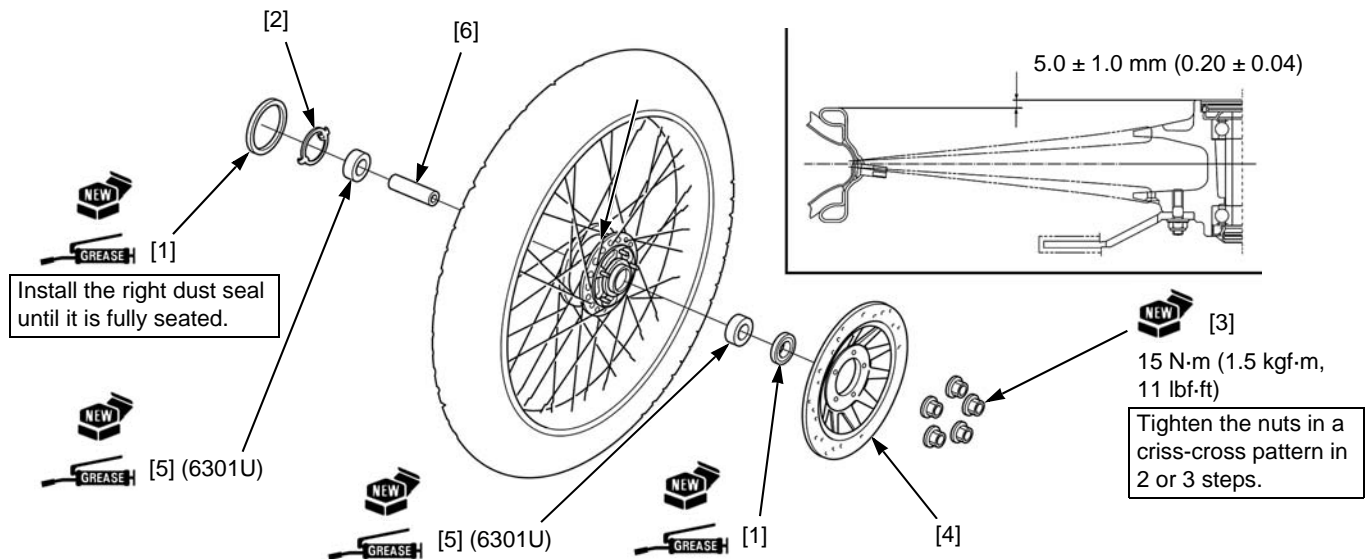

FRONT WHEEL/BRAKE/SUSPENSION/STEERING

XL125LK:

Remove/install the following:

- Dust seal [1]
 - Wheel bearings [2]
 - Distance collar [3]
- Replace the bearings and dust seals with new ones.
 - Apply grease to the dust seal lips and bearing cavities.

Refer to procedures for wheel bearing replacement (page 14-12).

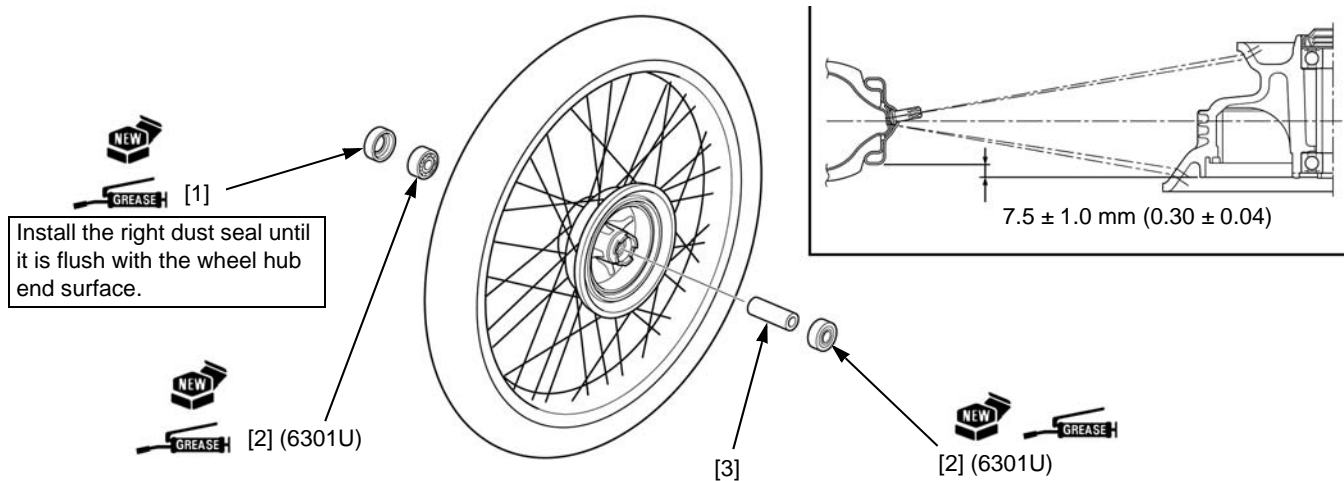

WHEEL BEARING REPLACEMENT

Install the remover head [1] into the bearing. From the opposite side of the wheel, install the remover shaft [2] and drive the bearing out of the wheel hub. Remove the distance collar and drive out the other bearing.

TOOLS:

Bearing remover head, 12 mm 07746-0050300
Bearing remover shaft 07746-0050100



Pack new bearing cavities with grease.

Drive in a new left side bearing [1] squarely with the sealed side facing up until it is fully seated.

Coat a distance collar with grease and install it. Drive in a new right side bearing with the sealed side facing up until it is seated on the distance collar.

TOOLS:

[2] Driver 07749-0010000
[3] Attachment, 37 x 40 mm 07746-0010200
[4] Pilot, 12 mm 07746-0040200

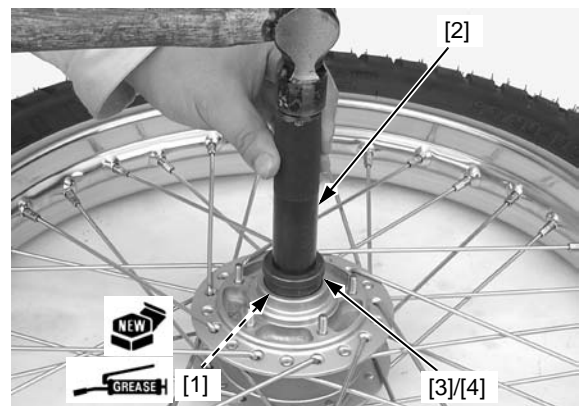

FRONT DRUM BRAKE (XL125LK)

DISASSEMBLY/ASSEMBLY

Remove/install the front wheel (page 14-9).

Disassemble and assemble the brake pedal as following illustration.

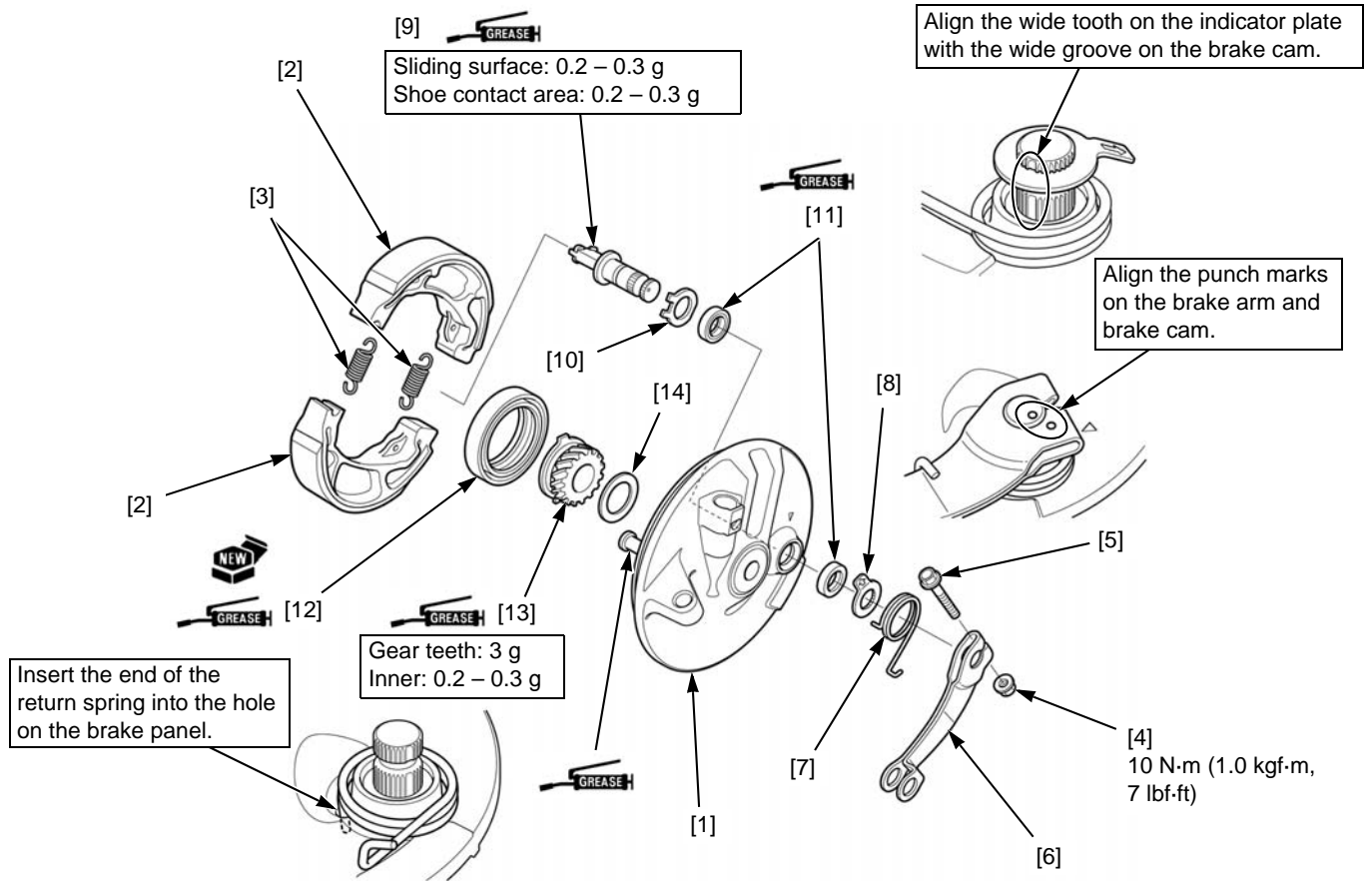

- Brake panel [1]
- Nut [4]
- Return spring [7]
- Retainer [10]
- Speedometer gear [13]
- Brake shoes [2]
- Brake arm bolt [5]
- Indicator plate [8]
- Brake cam dust seals [11]
- Shim [14]
- Brake shoe springs [3]
- Brake arm [6]
- Brake cam [9]
- Brake panel dust seal [12]

- Adjust the front brake lever freeplay (page 3-13).

FORK

REMOVAL

Remove the front wheel (page 14-9).

Support the caliper so it does not hang from the brake hose. Do not twist the brake hose.

Remove the following (XR125LK/LEK left fork only):

- Brake hose clamp cover [1]
- Bolts [2] and brake hose clamps [3]
- Bolts [4] and brake caliper [5]

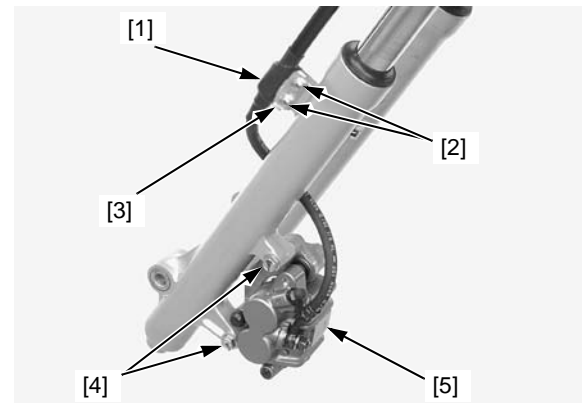

FRONT WHEEL/BRAKE/SUSPENSION/STEERING

Remove the following (XL125LK left fork only):

- Bolts [1]
- Brake cable guide [2]

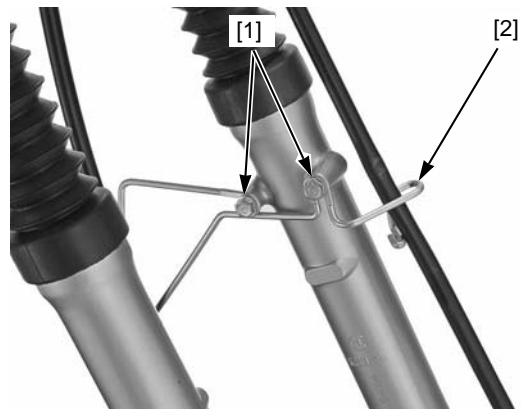

Loosen the top bridge pinch bolt [1].

Do not remove the fork cap yet.

Loosen the fork cap [2].

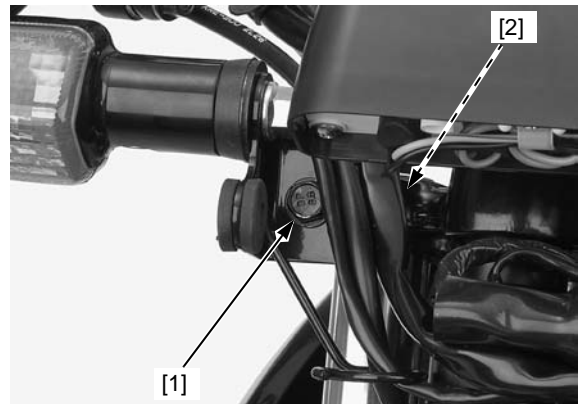

Loosen the fork bottom bridge pinch bolts [1] while holding the fork.
Remove the fork from the steering stem.

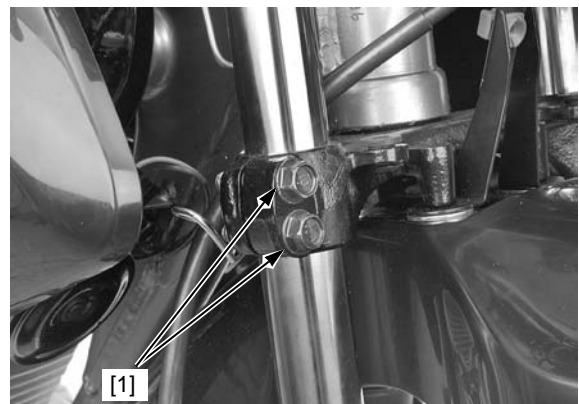

DISASSEMBLY

Loosen the boot band screw and remove the dust boot from the fork (XL125LK only).

The fork cap is under spring pressure. Wear an eye protector and a face protector while removing the cap.

Remove the fork cap [1] and O-ring [2] from the fork pipe.

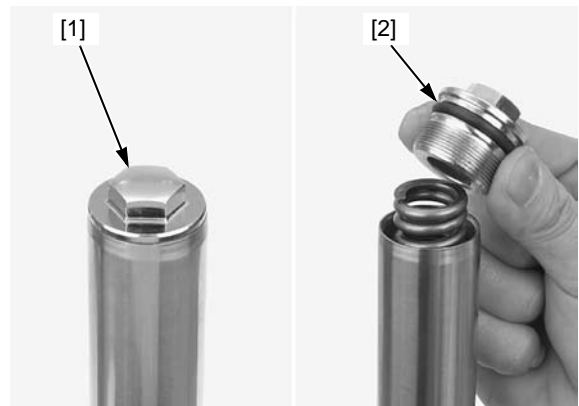

Remove the fork spring [1].
Pour the fork fluid from the fork leg by pumping the fork 8 – 10 times.

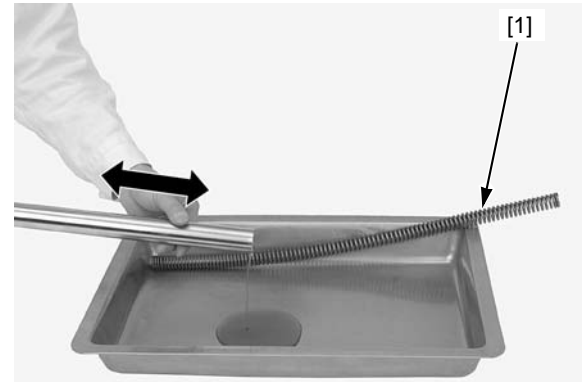

Hold the fork slider in a vise with a piece of wood or soft jaws to avoid damage.

Loosen and remove the fork socket bolt [1] and sealing washer from the fork slider.

If the fork piston turns with the socket bolt, temporarily install the fork spring, washer, spring spacer and fork cap.

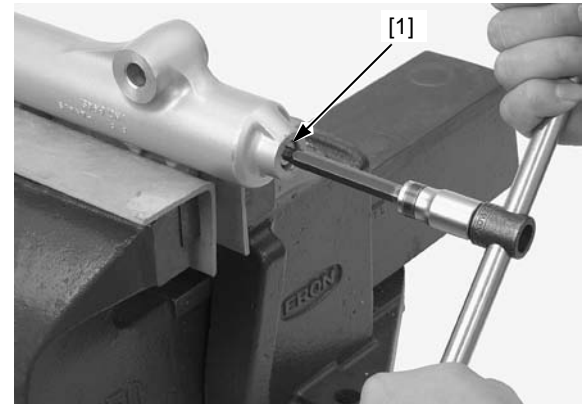

Remove the dust seal [1] from the fork slider.

Do not scratch the fork pipe sliding surface.

Remove the stopper ring [2] from the groove of the fork slider.

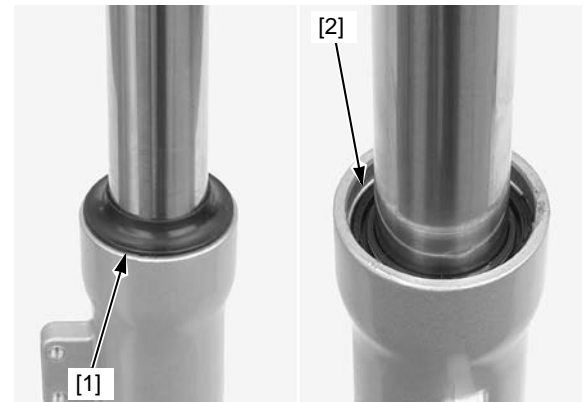

Check that the fork pipe moves smoothly in the fork slider. If not, check the fork pipe for bending or damage, and bushings for wear or damage.

Pull the fork pipe [1] out of the fork slider [2].
Remove the oil lock piece [3] from the fork slider.

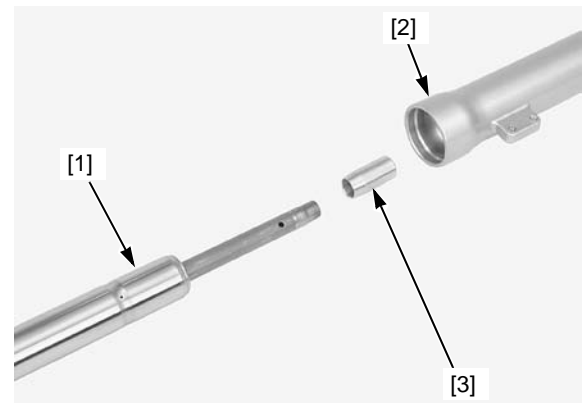

FRONT WHEEL/BRAKE/SUSPENSION/STEERING

Remove the oil seal [1] by using a commercially available oil seal remover.

TOOL:

[2] Oil seal remover 07748-0010001

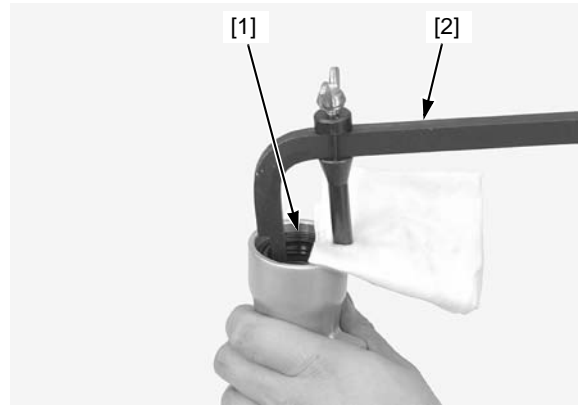

Remove the back-up ring [1] from the fork slider.

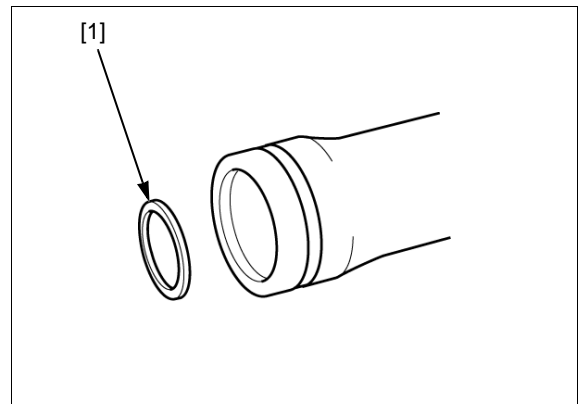

Remove the fork piston [1] and rebound spring [2] from the fork pipe [3].

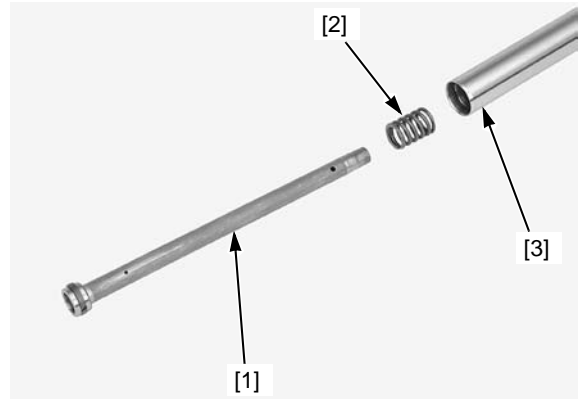

INSPECTION

FORK SPRING

Measure the fork spring free length on a flat surface.

SERVICE LIMIT:

XR125LK/LEK: 582.6 mm (22.94 in)

XL125LK: 593.4 mm (23.36 in)

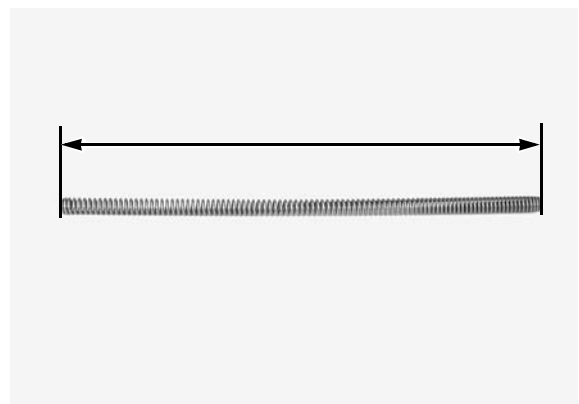

FORK PIPE/SLIDER/FORK PISTON

Check the fork pipe [1], fork slider [2], fork piston [3] and oil lock piece [4] for scratches and excessive or abnormal wear.
 Check the fork piston ring [5] for wear or damage.
 Check the rebound spring [6] for fatigue and damage.

Replace the component if necessary.

Set the fork pipe in V-blocks, rotate the fork pipe, and measure its runout with a dial indicator.
 The actual runout reading is 1/2 of the total indicator reading.

SERVICE LIMIT: 0.20 mm (0.008 in)

Replace it if the service limit is exceeded or it has scratches or nicks that will cause fork fluid to leak out of the seals.

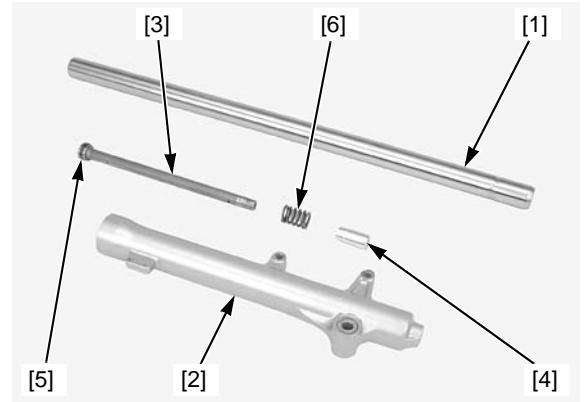

FORK PIPE BUSHING

Visually inspect the slider bushing.
 Replace the fork slider if they are worn, or if the Teflon coating is worn and 3/4 or over of the copper surface appears.

Check the back-up ring; replace it if there is any distortion at the points indicated by arrows on the figure.

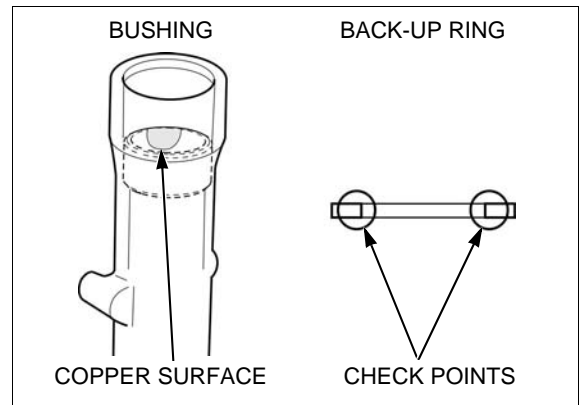

ASSEMBLY

XR125LK/LEK shown:

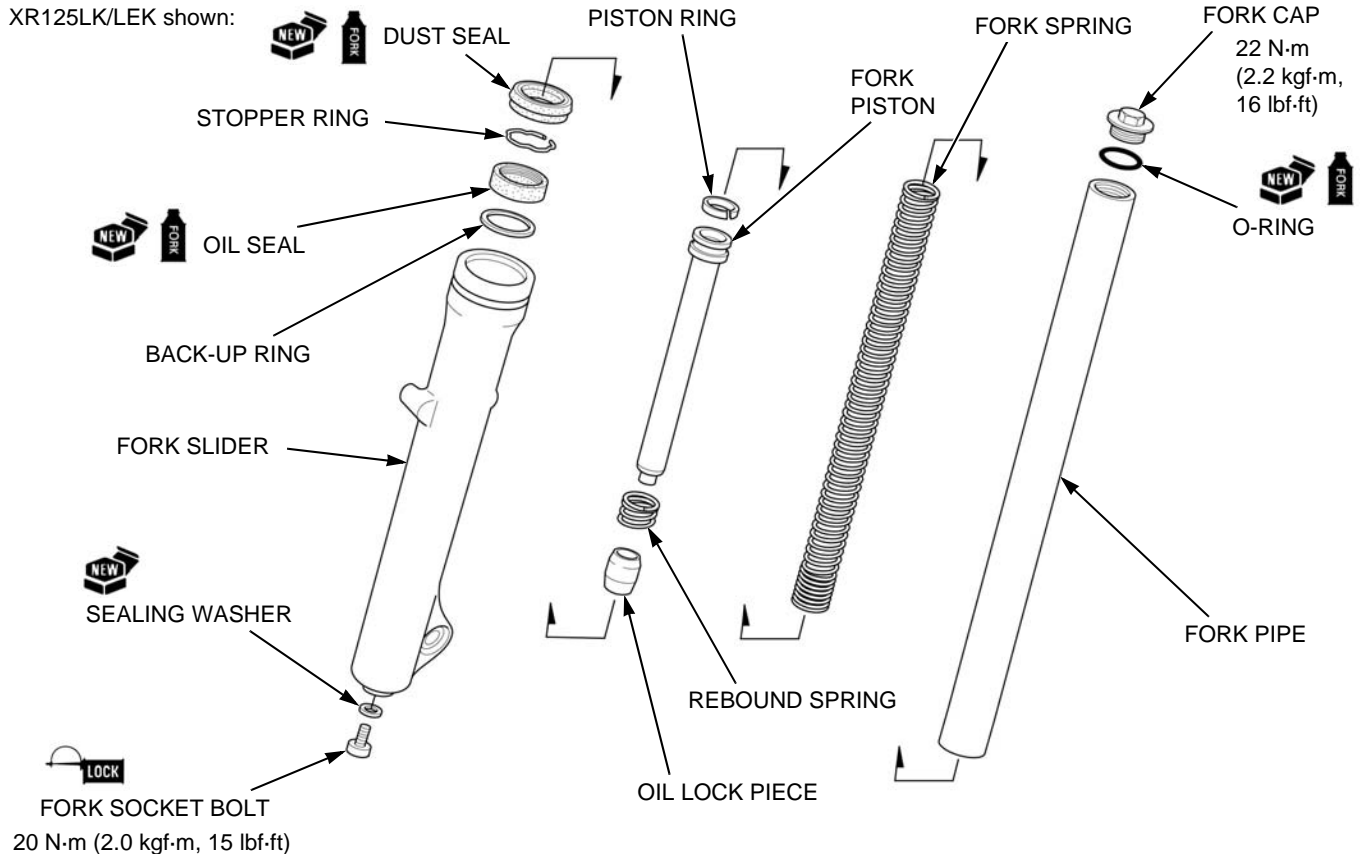

FRONT WHEEL/BRAKE/SUSPENSION/STEERING

Install the rebound spring [1] to the fork piston [2].
Install the fork piston into the fork pipe [3].

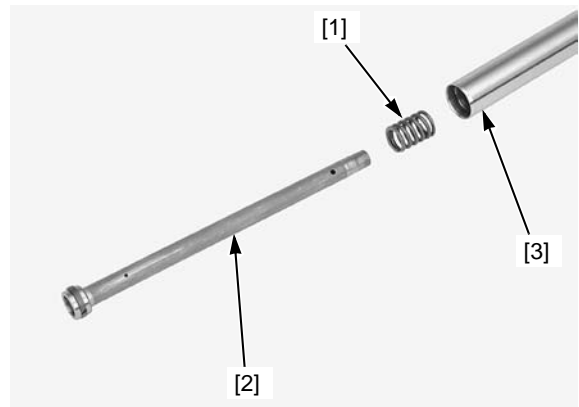

Install the oil lock piece [1] onto the fork piston [2] end.
Apply fork fluid to the fork slider bushing [3], and install the fork pipe [4] into the fork slider [5].

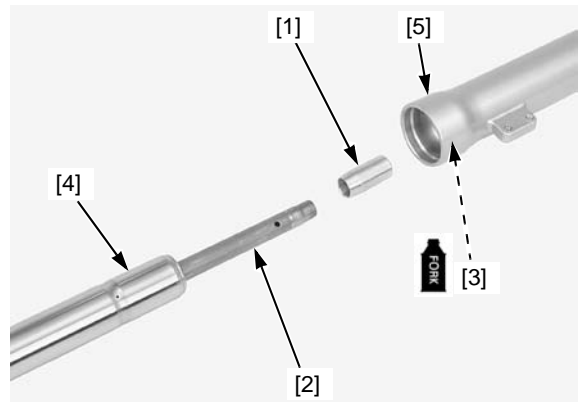

Do not overtighten the fork slider.

Hold the axle holder of the fork slider in a vise with a piece of wood or soft jaws to avoid damage.
Clean the fork socket bolt threads and apply a locking agent to them.
Install the fork socket bolt [1] in the fork piston with a new sealing washer [2].

If the fork piston turns together with the socket bolt, temporarily install the fork spring and fork cap

Tighten the fork socket bolt to the specified torque.

TORQUE: 20 N·m (2.0 kgf·m, 15 lbf·ft)

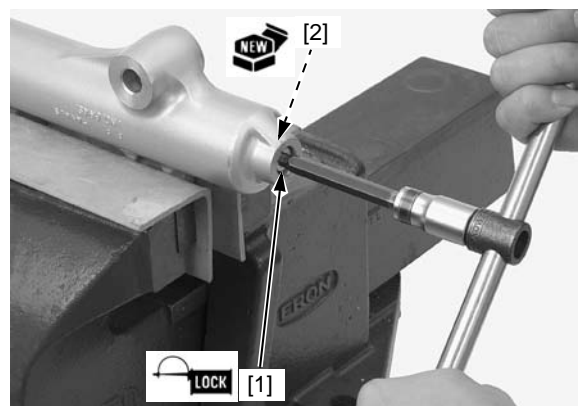

Install the back-up ring [1] into the fork slider.

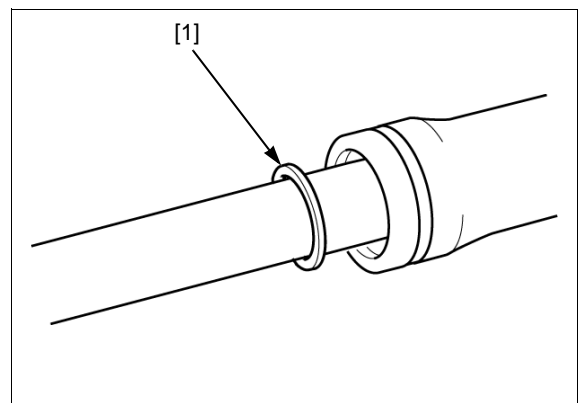

Apply fork oil to the lip of a new oil seal [1] and drive it into the fork slider with the special tools until the stopper ring groove [2] becomes visible.

TOOLS:

- [3] Fork seal driver 07747-0010100
- [4] Driver attachment, 31.2 mm 07747-0010400

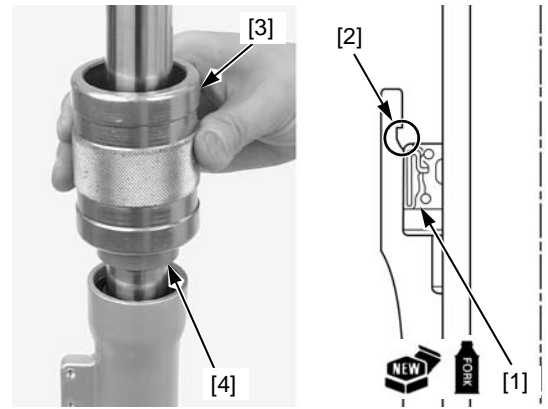

Install the stopper ring [1] into the groove of the fork slider.
Apply fork oil to the lip of a new dust seal [2] and install it.

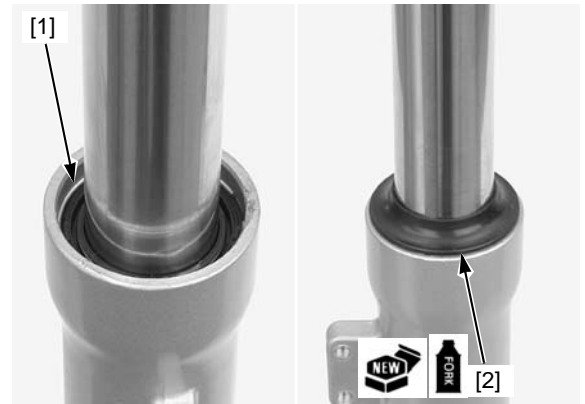

Pour half of the required amount of the recommended fork fluid into the fork pipe.

RECOMMENDED FORK FLUID:

Honda ULTRA CUSHION OIL 10W or equivalent

FORK FLUID CAPACITY:

180 ± 2.5 cm³ (6.1 ± 0.08 US oz, 6.3 ± 0.09 Imp oz)

Pump the fork pipe slowly several times to remove trapped air.

Pour additional fluid up to the specified capacity and repeat the above step.

Compress the fork leg fully.

Measure the fluid level from the top of the fork pipe.

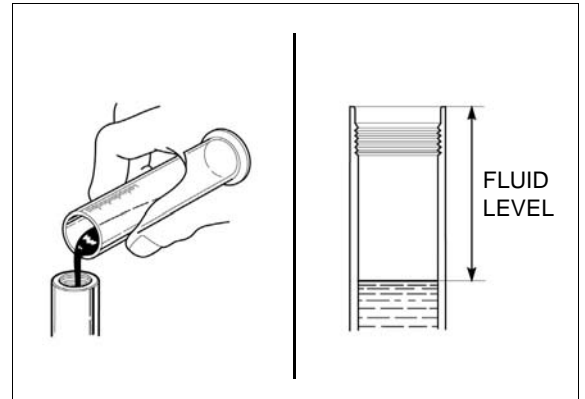

FLUID LEVEL:

XR125LK/LEK: 179 mm (7.0 in)

XL125LK: 194 mm (7.6 in)

Wipe fluid off the spring thoroughly with a clean cloth.
Install the fork spring with the tightly wound coil side facing down.

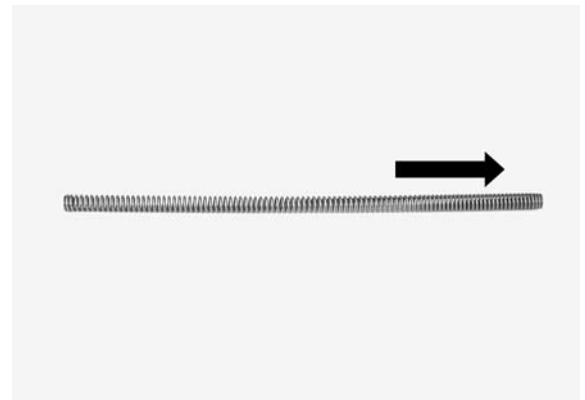

FRONT WHEEL/BRAKE/SUSPENSION/STEERING

Tighten the fork cap after installing the fork pipe into the fork bridge.

Apply fork fluid to new O-ring [1] and install it to the fork cap [2].
Install the fork cap into the fork pipe.



XL125LK only: Install the dust boot with its breathing hole [1] facing rearward.
Set the boot band screw [2] as shown in the illustration.

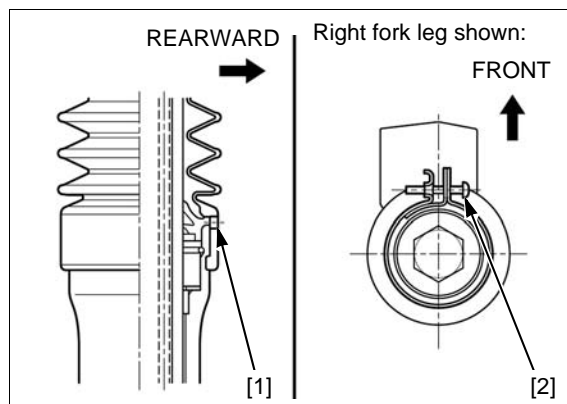

INSTALLATION

Install the fork pipe [1] into the bottom bridge [2].

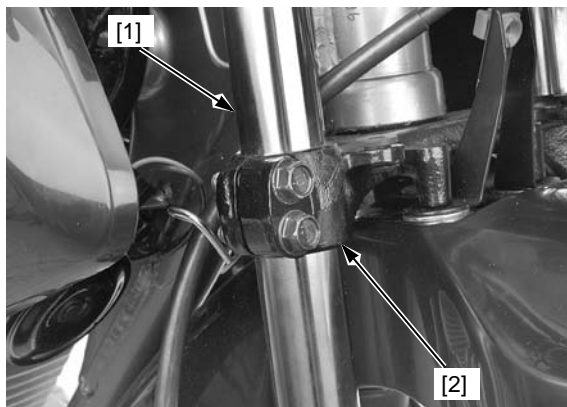

Align the top end of the fork pipe with the upper surface of the top bridge as shown.

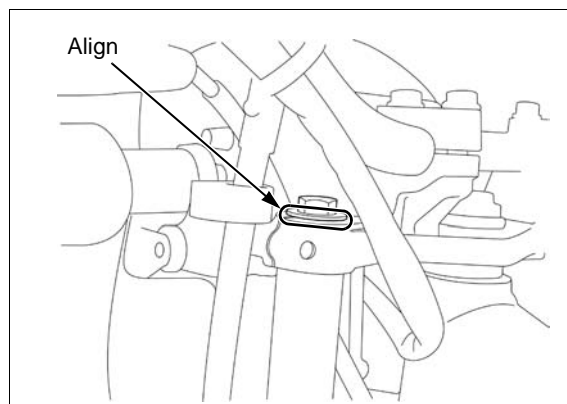

FRONT WHEEL/BRAKE/SUSPENSION/STEERING

Tighten the bottom bridge pinch bolts [1] to the specified torque.

TORQUE: 32 N·m (3.3 kgf·m, 24 lbf·ft)

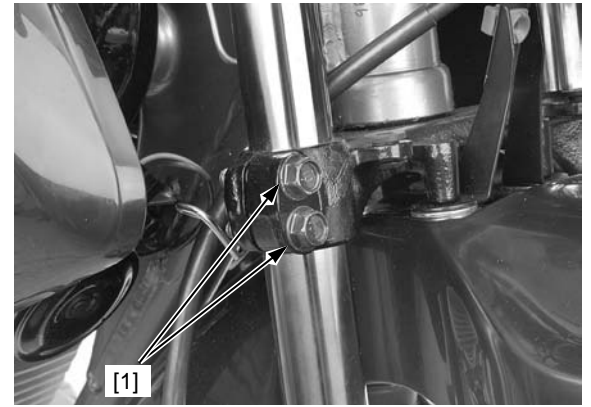

Tighten the fork cap [1] to the specified torque.

TORQUE: 22 N·m (2.2 kgf·m, 16 lbf·ft)

Tighten the top bridge pinch bolt [2] to the specified torque.

TORQUE: 22 N·m (2.2 kgf·m, 16 lbf·ft)

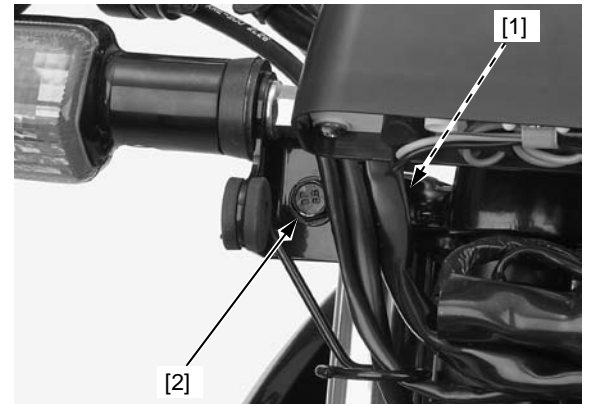

XL125LK: Seat the upper end of the boot [1] on the bottom bridge. Tighten the boot band screw [2].

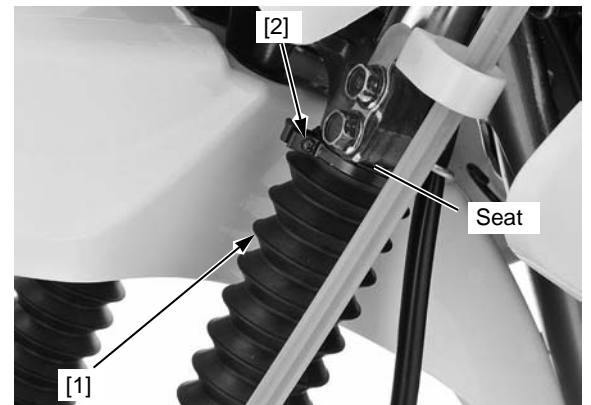

XR125LK/LEK: Install the brake caliper [1] with new mounting bolts [2], and then tighten the bolts to the specified torque.

TORQUE: 30 N·m (3.1 kgf·m, 22 lbf·ft)

Install the brake hose clamps [3], cover [4] and bolts [5]. Tighten the bolts securely.

Install the front wheel (page 14-9).

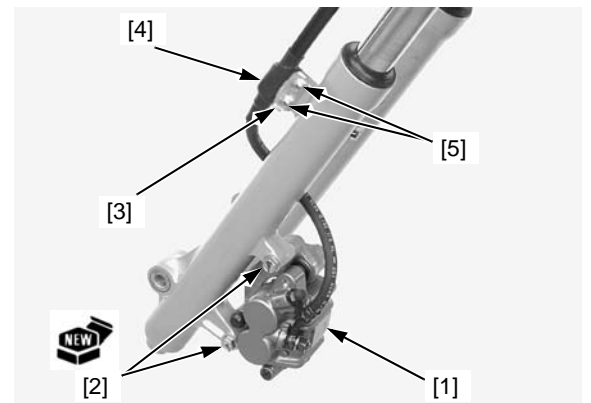

FRONT WHEEL/BRAKE/SUSPENSION/STEERING

XL125LK: Install the brake cable guide [1] and route the brake cable [2].

Install and tighten the bolts [3] securely.

Install the front wheel (page 14-11).

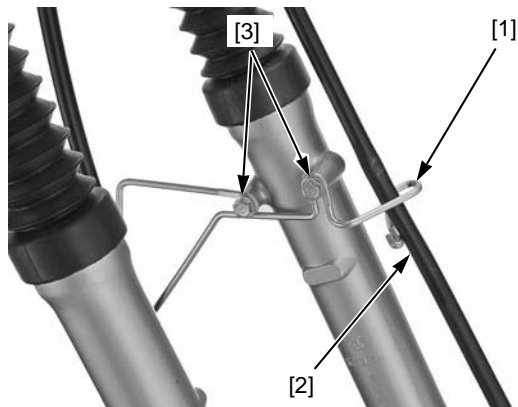

STEERING STEM

REMOVAL

Remove the following:

- Front wheel (page 14-9)
- Front visor (page 2-4)
- Combination meter (page 18-6)
- Handlebar (page 14-4)

Disconnect the turn signal light (Green, Orange, Light blue) wire connectors [1].

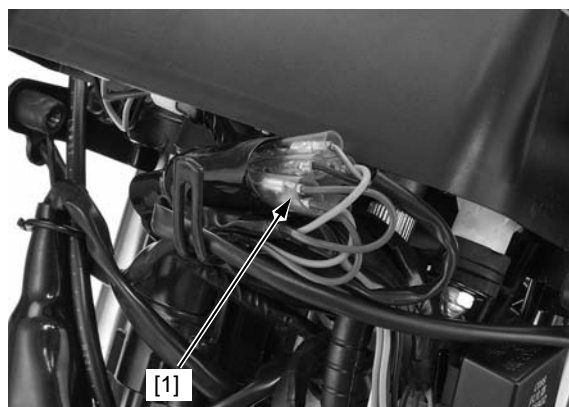

Remove the top bridge pinch bolts [1] and turn signal lights [2].

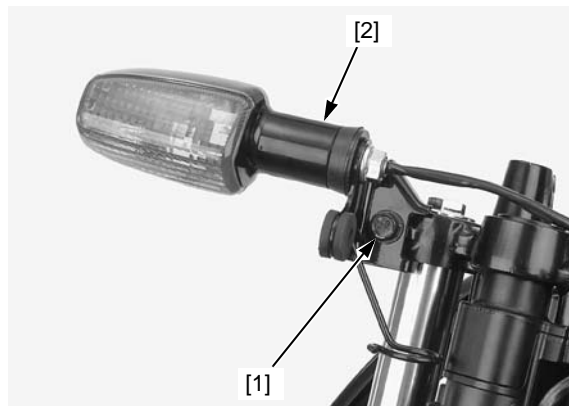

Remove the steering stem cap [1], stem nut [2] and washer [3].

Remove the top bridge [4].

Remove the forks (page 14-13).

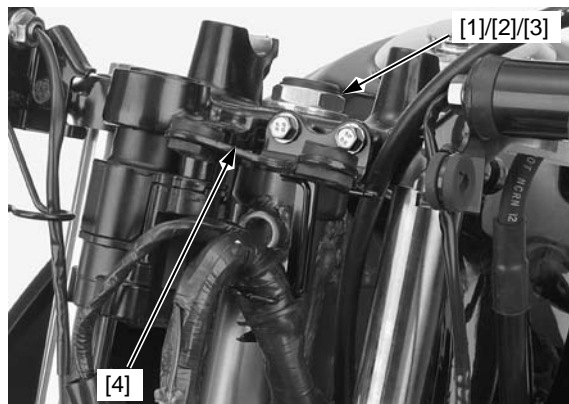

Hold the steering stem and remove the steering stem adjusting nut [1] with the special tool.

TOOL:

[2] **Steering stem socket wrench 07916-KA50100**

Remove the upper dust seal [3].

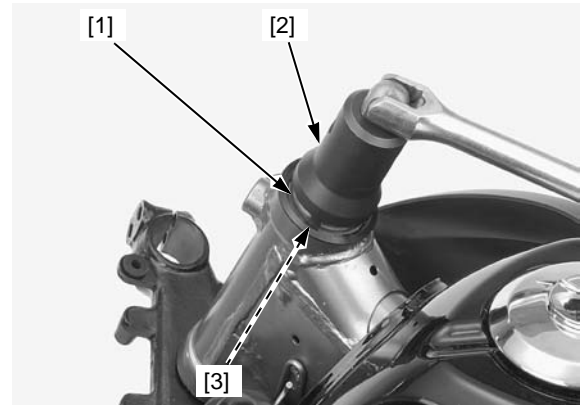

Remove the upper bearing inner race [1] and upper bearing [2].

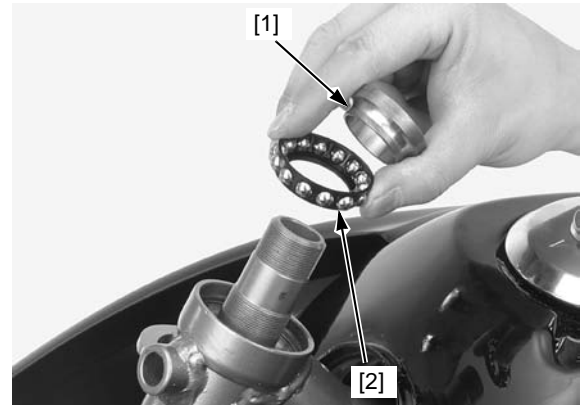

Remove the steering stem [1] from the steering head pipe.

Remove the lower bearing [2].

Check the steering bearings, inner and outer races for wear or damage.

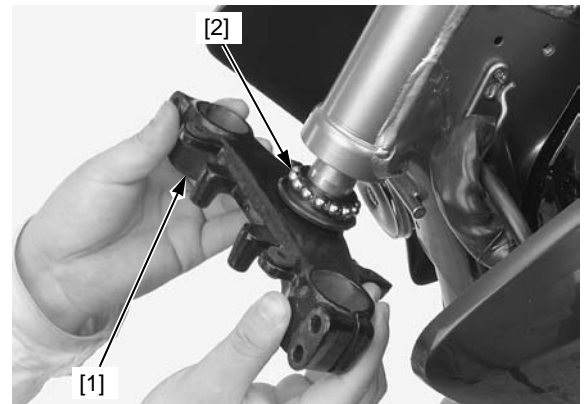

STEERING BEARING RACE REPLACEMENT

Always replace the bearings and races in pairs.

Remove the upper bearing outer race [1] and lower bearing outer race [2] with the following tools.

TOOLS:

[3] **Ball race remover shaft**
[4] **Ball race remover**

07944-1150001
07948-4630100

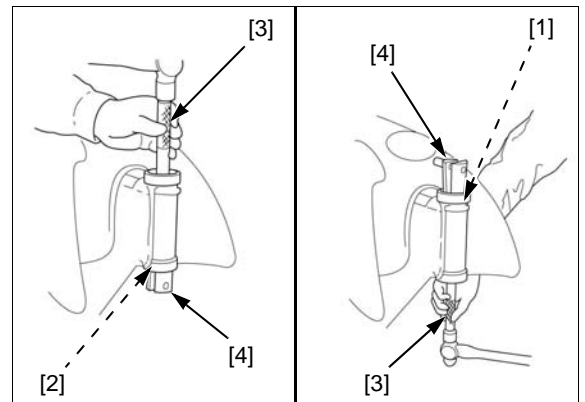

FRONT WHEEL/BRAKE/SUSPENSION/STEERING

Install the stem nut [1] onto the stem to prevent the threads from being damaged when removing the lower bearing inner race from the stem.

Remove the lower bearing inner race [2] with a chisel or an equivalent tool without damaging the stem.

Remove the dust seal [3].

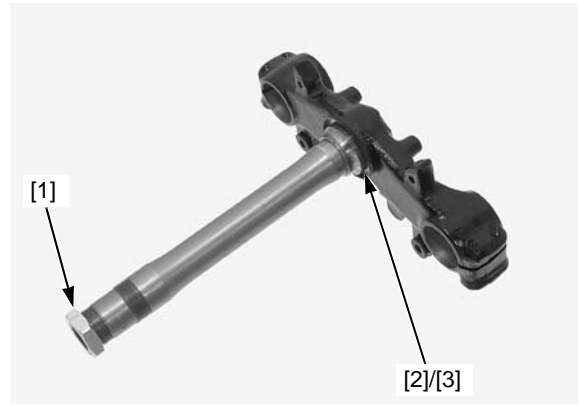

Do not damage the steering stem during installation.

Apply grease to lip of a new dust seal [1].

Install the dust seal.

Install the new lower bearing inner race [2] with the following tool and a hydraulic press.

TOOL:

[3] Steering stem driver

07946-4300101

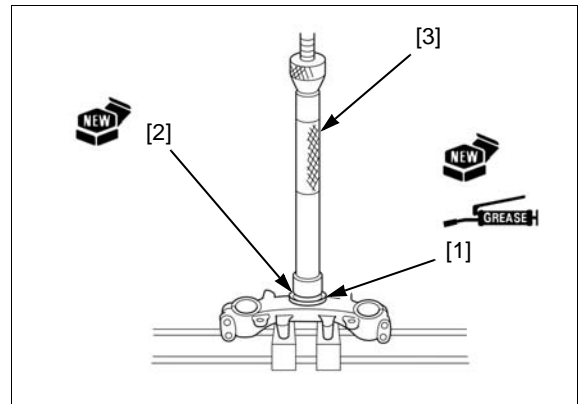

Drive the new upper bearing outer race [1] into the head pipe with the following tools.

TOOLS:

[2] Driver

07749-0010000

[3] Attachment, 42 x 47 mm

07746-0010300

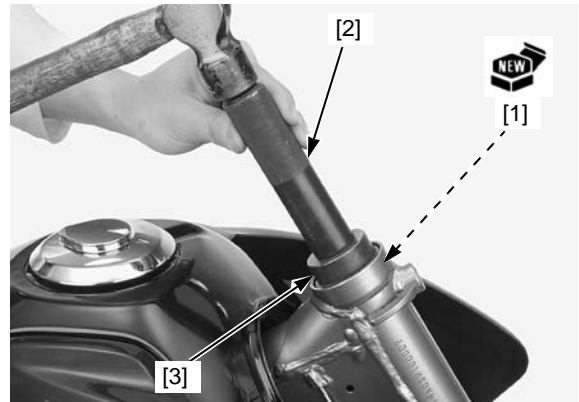

Drive the new lower bearing outer race [1] into the head pipe with the following tools.

TOOLS:

[2] Driver

07749-0010000

[3] Attachment, 42 x 47 mm

07746-0010300

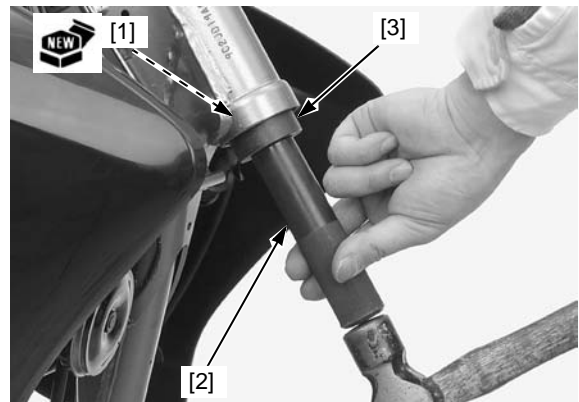

INSTALLATION

 UREA BASED GREASE WITH EXTREME PRESSURE AGENT

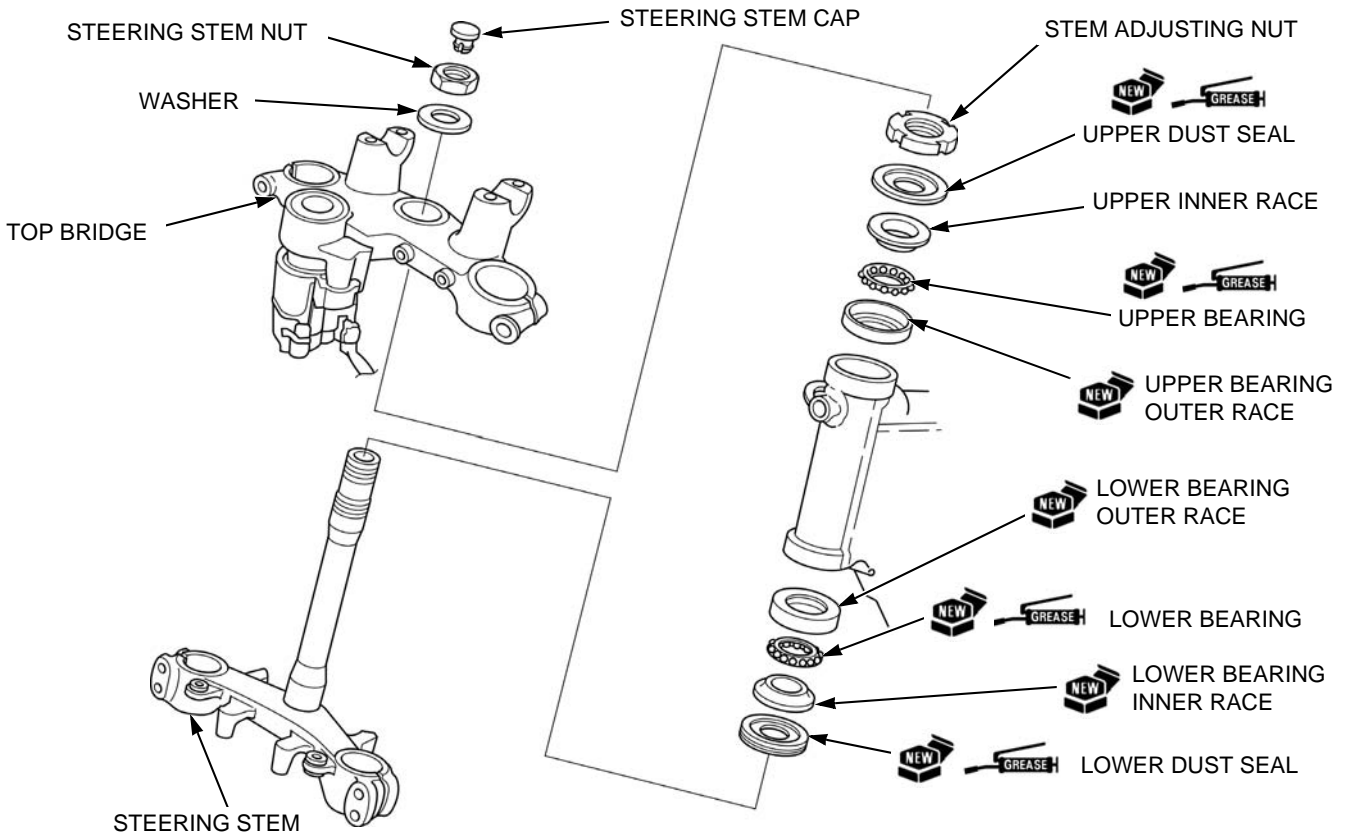

Apply urea based multi-purpose grease (page 1-15) to a new lower bearing [1].
Install the lower bearing onto the steering stem [2].
Install the steering stem into the head pipe.

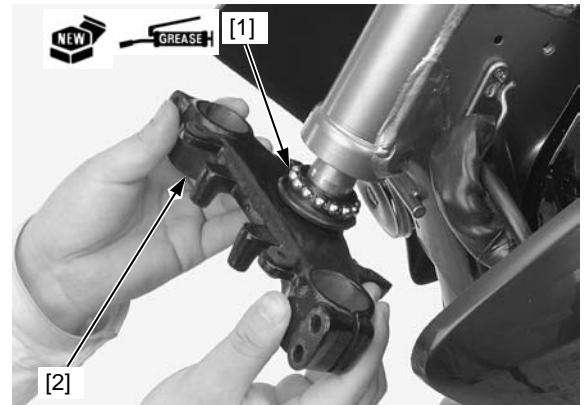

Apply urea based multi-purpose grease (page 1-15) to a new upper bearing [1].
Install the upper bearing.
Install the upper bearing inner race [2].

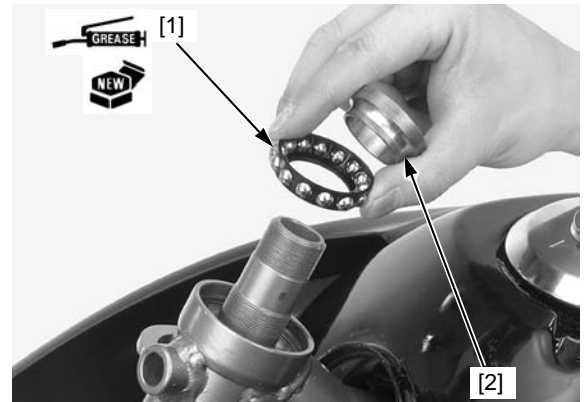

FRONT WHEEL/BRAKE/SUSPENSION/STEERING

Apply urea based multi-purpose grease (page 1-15) to lip of a new upper dust seal [1] and install it. Install the steering stem adjusting nut [2]. Tighten the steering stem adjusting nut to the specified torque.

TOOL:

[3] Steering stem socket wrench 07916-KA50100

TORQUE: 5.0 N·m (0.5 kgf·m, 3.7 lbf·ft)

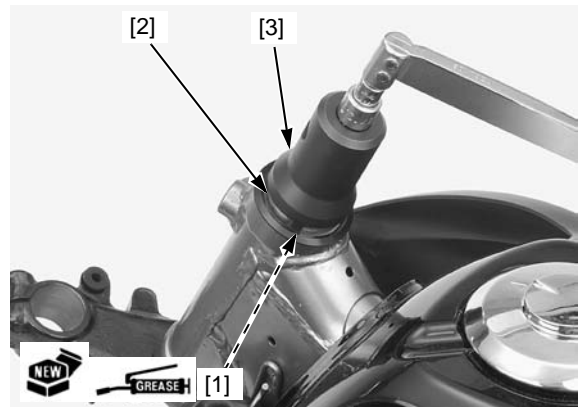

Turn the steering stem right and left to the end at least five times to seat the bearings.

Loosen the steering stem adjusting nut completely.



Retighten the adjusting nut to the specified torque.

TOOL:

[1] Steering stem socket wrench 07916-KA50100

TORQUE: 5.0 N·m (0.5 kgf·m, 3.7 lbf·ft)

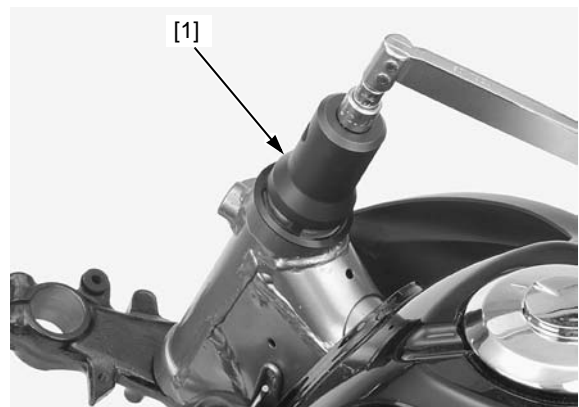

Install the top bridge [1].

Temporarily install the front fork (page 14-20).

Install the steering stem nut [2] and washer [3].

Tighten the steering stem nut to the specified torque with a special tool.

TORQUE: 103 N·m (10.5 kgf·m, 76 lbf·ft)

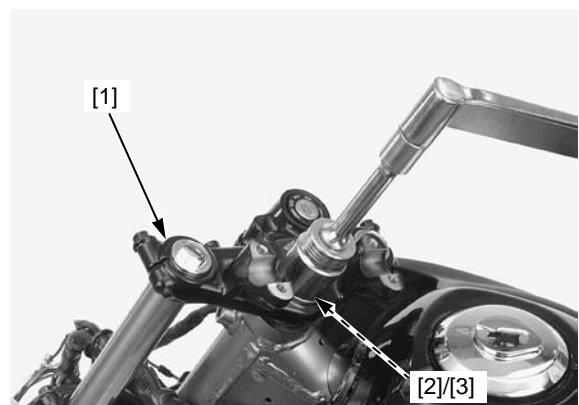

Install the steering stem cap [1].

Make sure that the steering stem moves smoothly, not loosely or tightly.

Install the meter holder and two bolts.

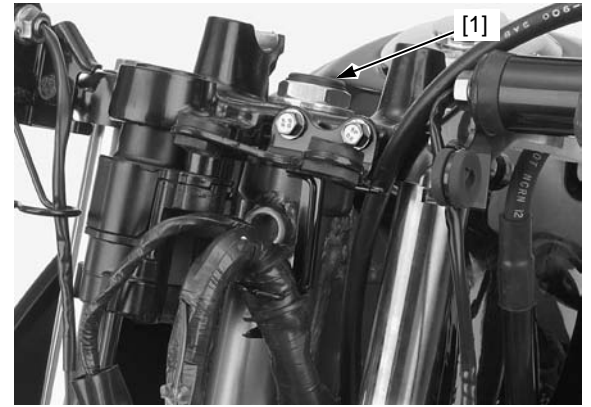

Install the turn signal lights [1] and top bridge pinch bolts [2].

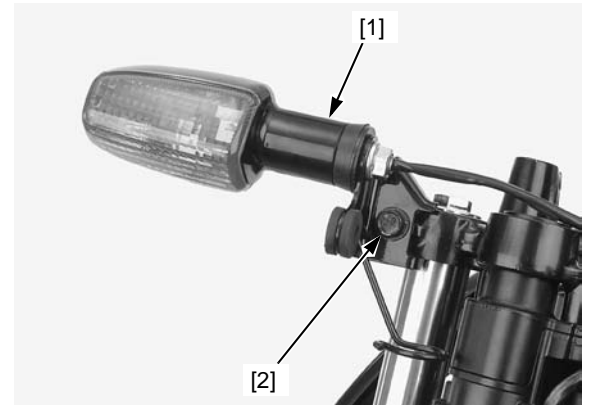

Connect the turn signal light connectors [1].

Install the bottom bridge pinch bolts.

Install the forks (page 14-20).

Install the following:

- Combination meter (page 18-6)
- Front visor (page 2-4)
- Handlebar (page 14-6)
- Front wheel (page 14-9)

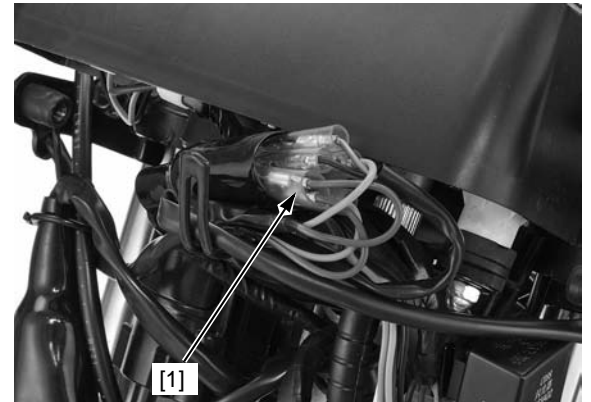

STEERING BEARING PRELOAD

Raise the front wheel off the ground.

Position the steering stem to the straight ahead position.

Hook a spring scale to the fork tube between the fork top and bottom bridges.

Make sure that there is no cable or wire harness interference.

Pull the spring scale keeping the scale at a right angle to the steering stem.

Read the scale at the point where the steering stem just starts to move.

STEERING BEARING PRELOAD:

11.8 – 17.7 N (1.2 – 1.8 kgf, 2.6 – 4.0 lbf)

If the readings do not fall within the limits, readjust the steering top thread.

Install the removed parts in the reverse order of removal.

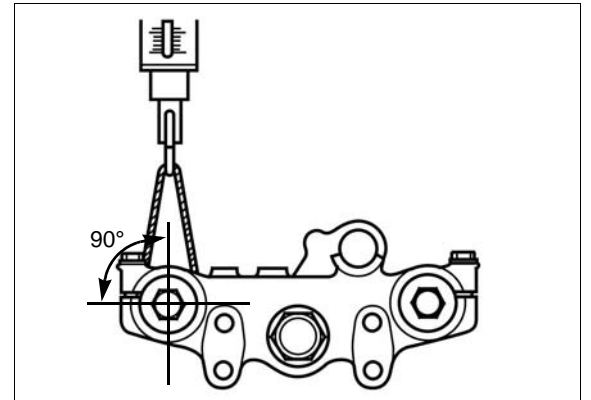

MEMO

15. REAR WHEEL/BRAKE/SUSPENSION

SYSTEM COMPONENTS.....	15-2	REAR DRUM BRAKE	15-7
SERVICE INFORMATION	15-3	BRAKE PEDAL	15-9
TROUBLESHOOTING.....	15-3	SHOCK ABSORBER	15-11
REAR WHEEL	15-4	SWINGARM	15-13

REAR WHEEL/BRAKE/SUSPENSION SYSTEM COMPONENTS

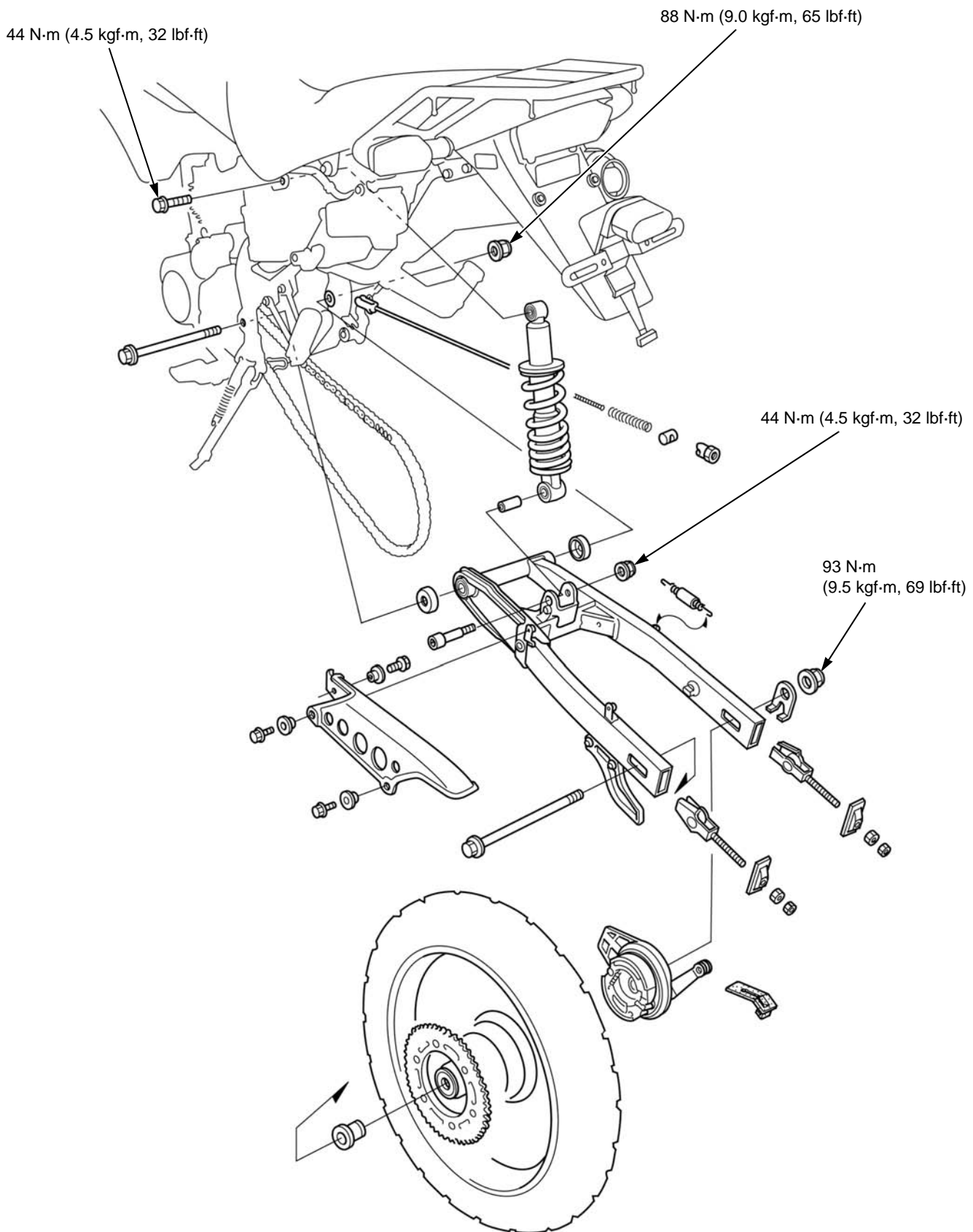

SERVICE INFORMATION

GENERAL

⚠ CAUTION

Frequent inhalation of brake shoe dust, regardless of material composition could be hazardous to your health.

- Avoid breathing dust particles.
- Never use an air hose or brush to clean brake assemblies. Use an OSHA-approved vacuum cleaner.

- When servicing the rear wheel and suspension, support the motorcycle using a safety stand or hoist.
- A contaminated brake drum or shoe reduces stopping power. Discard contaminated shoes and clean a contaminated drum with a high quality brake degreasing agent.
- Use genuine Honda replacement bolts and nuts for all suspension pivots and mounting points.
- Refer to page 3-9 for drive chain information.

TROUBLESHOOTING

Rear wheel wobbles

- Bent rim
- Worn or damaged rear wheel bearings
- Faulty rear tire
- Loose or broken spokes
- Worn or damaged swingarm bearings
- Bent frame or swingarm
- Axle fastener not tightened properly

Wheel turns hard

- Brake drag
- Faulty wheel bearings
- Bent axle
- Drive chain too tight (page 3-9)

Soft suspension

- Incorrect suspension adjustment
- Weak shock absorber springs
- Oil leakage from damper unit
- Low tire pressure

Hard suspension

- Incorrect suspension adjustment
- Bent shock absorber damper rod
- Damaged suspension or swingarm pivot bearings
- Bent swingarm pivot or frame
- High tire pressure

Steers to one side or does not track straight

- Drive chain adjusters not adjusted equally
- Bent axle
- Bent frame
- Worn swingarm pivot components

Rear suspension noise

- Loose suspension fasteners
- Worn or damaged suspension pivot bearings
- Faulty shock absorber

REAR WHEEL

REMOVAL

Support the motorcycle securely with a hoist or an equivalent and raise the rear wheel off the ground.

Remove the rear brake adjusting nut [1] and disconnect the rear brake rod [2] from the brake arm [3].

Remove the joint pin [4] and spring [5].

Loosen the left and right drive chain lock nuts [6] and adjusting nuts [7].

Remove the rear axle nut [8] and axle plate [9].

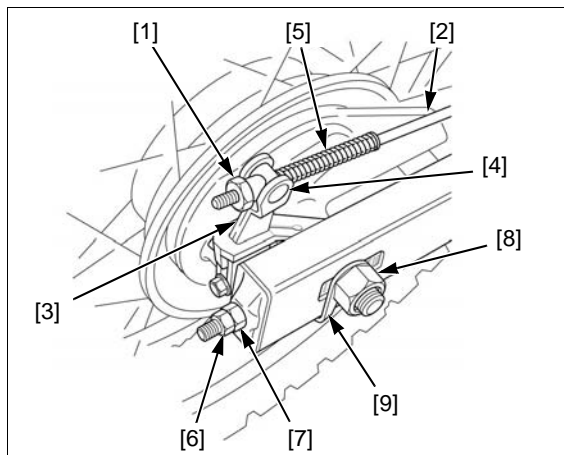

Push the rear wheel forward.

Derail the drive chain [1].

Remove the rear axle [2] from the left, then the rear wheel.

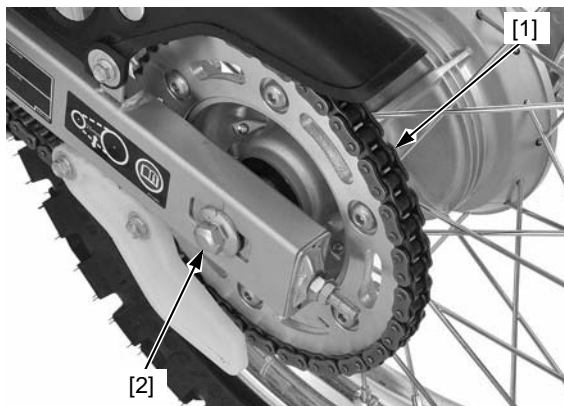

Remove the brake panel [1].

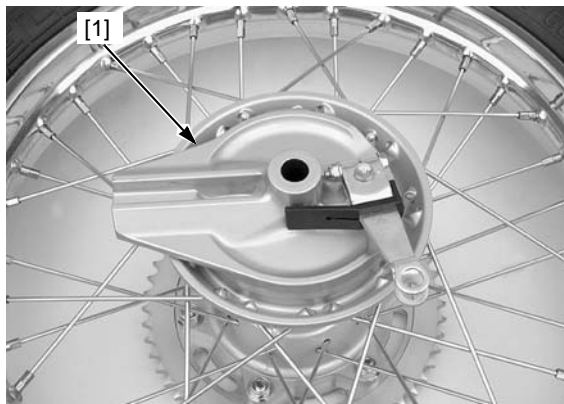

Remove the side collar [1].

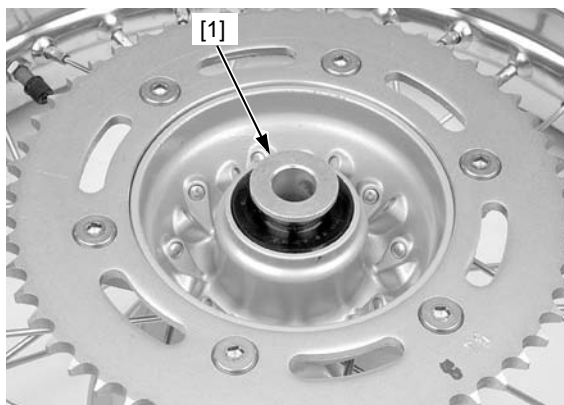

ASSEMBLY

Remove/install the following:

- Dust seal [1]
- Bolts [4]
- Distance collar [7]
- Nuts [2]
- Driven sprocket [5]
- Left wheel bearing (6303U) [8]
- Washers [3]
- Right wheel bearing (6203UU) [6]

- Replace the bearings and dust seal with new ones.
- Apply grease to the dust seal lip and bearing cavities.

Refer to procedures for bearing replacement (page 15-6).

XR125LK/LEK shown:

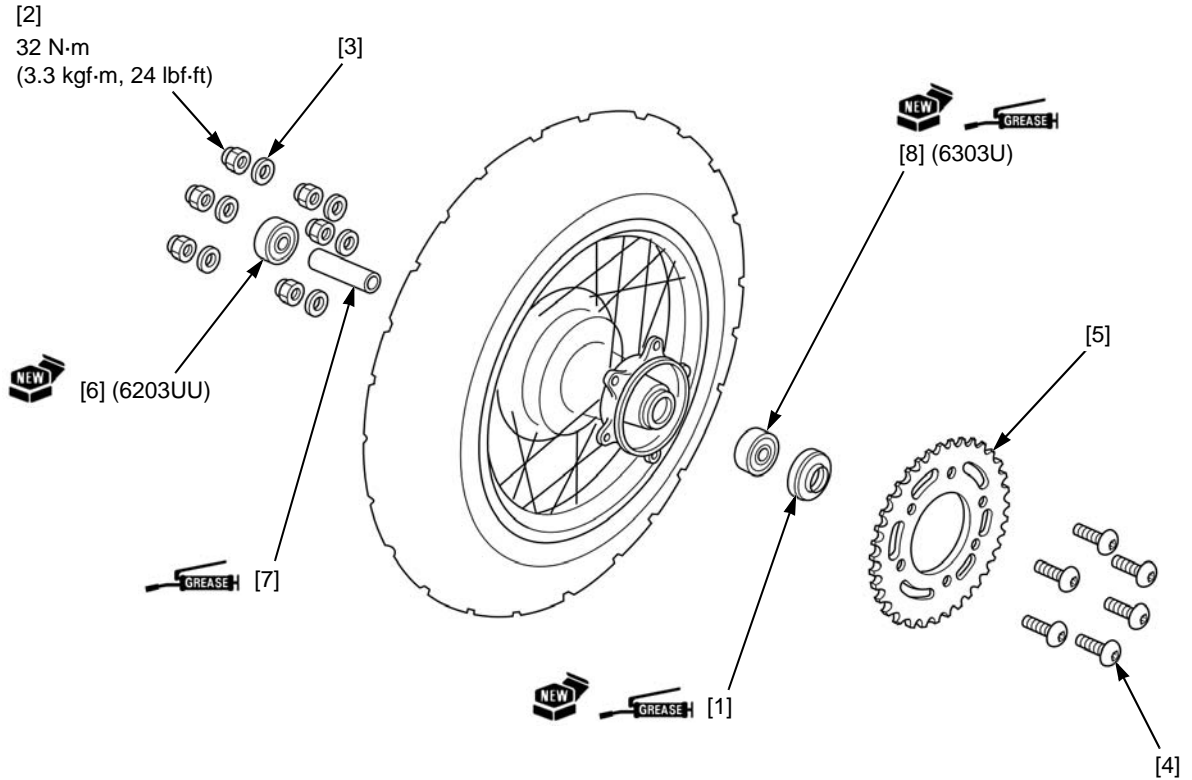

WHEEL CENTER ADJUSTMENT

Adjust the hub position so that the distance from the left end surface of the hub center to the side of rim is 18.0 ± 1.0 mm (0.71 ± 0.04 in) as shown.

Tighten the spokes in 2 or 3 progressive steps.

TOOL:

Spoke wrench, 5.8 x 6.1 mm 07701-0020300

TORQUE: 3.7 N·m (0.4 kgf·m, 2.7 lbf·ft)

XR125LK/LEK shown:

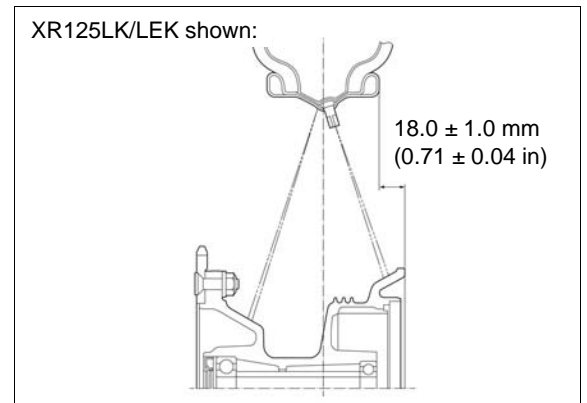

REAR WHEEL/BRAKE/SUSPENSION

WHEEL BEARING REPLACEMENT

Install the remover head into the bearing.
From the opposite side of the wheel, install the bearing remover shaft and drive the bearing out of the wheel hub.
Remove the distance collar and drive out the other bearing.

TOOLS:

[1] Bearing remover head, 17 mm 07746-0050500
[2] Bearing remover shaft 07746-0050100

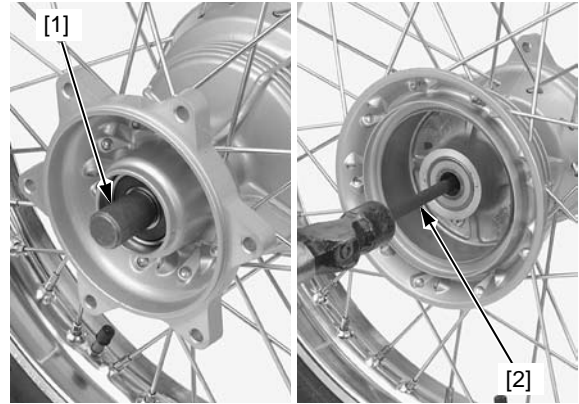

Drive in a new right side (brake drum side) bearing squarely with the sealed side facing up until it is fully seated.

TOOLS:

Driver 07749-0010000
Attachment, 37 x 40 mm 07746-0010200
Pilot, 17 mm 07746-0040400

Coat a distance collar with grease and install it.
Pack new bearing cavities with grease.
Drive in a new left side (driven sprocket side) bearing [1] with the sealed side facing up until it is fully seated.

TOOLS:

[2] Driver 07749-0010000
[3] Attachment, 42 x 47 mm 07746-0010300
[4] Pilot, 17 mm 07746-0040400

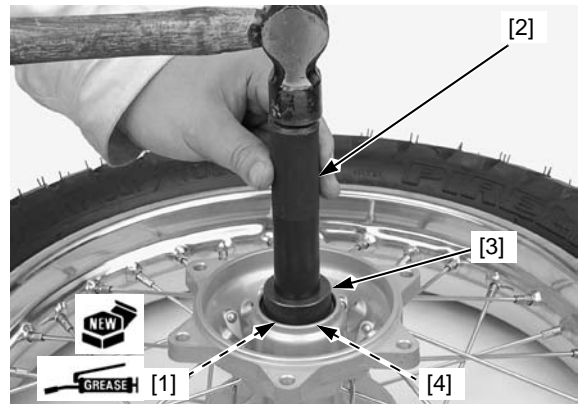

INSTALLATION

Install the side collar [1].

Do not get grease on the brake drum and shoe linings.

Install the brake panel [2] into the wheel hub.

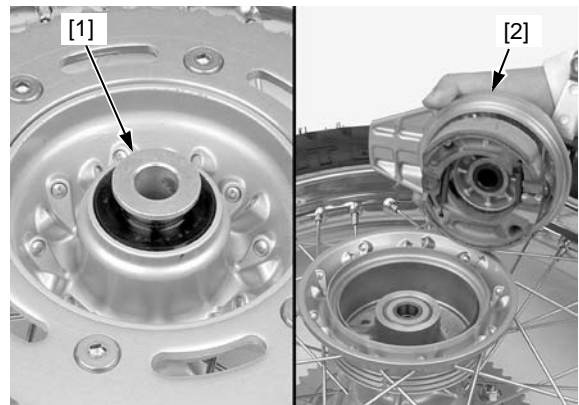

Place the rear wheel in the swingarm by aligning the brake panel groove with the swingarm boss.

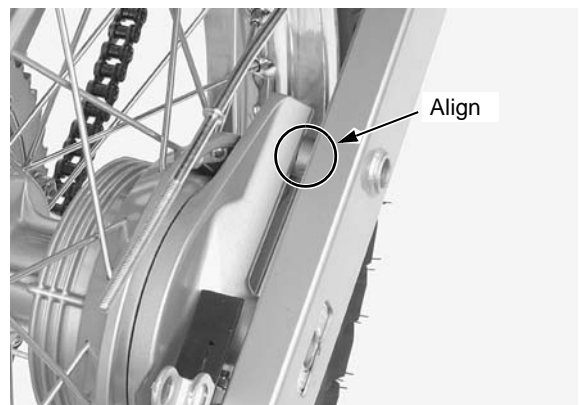

Apply grease to the rear axle [1].
 Insert the rear axle through the left drive chain adjuster, left side collar, rear wheel, brake panel and right chain adjuster.
 Install the drive chain [2] onto the driven sprocket.

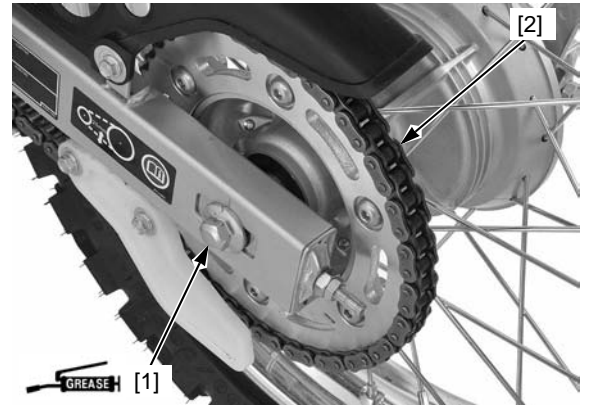

Install the axle plate [1] and axle nut [2], then tighten the nut to the specified torque.

TORQUE: 93 N-m (9.5 kgf-m, 69 lbf-ft)

Install the spring [3] onto the brake rod.
 Connect the brake rod [4] to the brake arm [5] with the joint pin [6] and adjusting nut [7].
 Adjust the drive chain slack (page 3-9).
 Adjust the brake pedal free play (page 3-14).

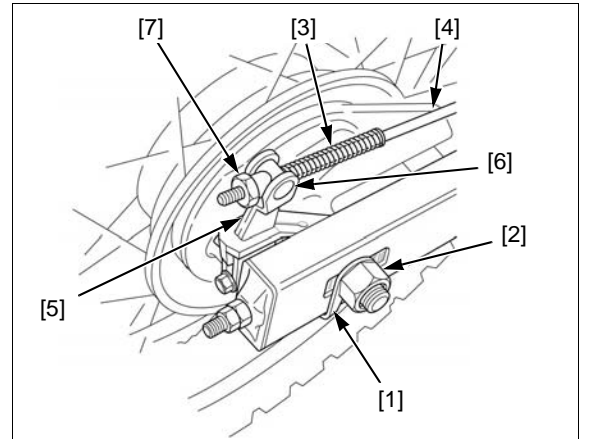

REAR DRUM BRAKE

DISASSEMBLY

Remove the rear wheel (page 15-4).
 Disassemble the brake panel as following illustration.

- Brake shoes [1]
- Shoe springs [2]
- Brake arm cover [3]
- Nut [4]
- Brake arm bolt [5]
- Brake arm [6]
- Indicator plate [7]
- Brake cam [8]
- Dust seals [10]
- Brake panel [11]
- Lock washer [9]

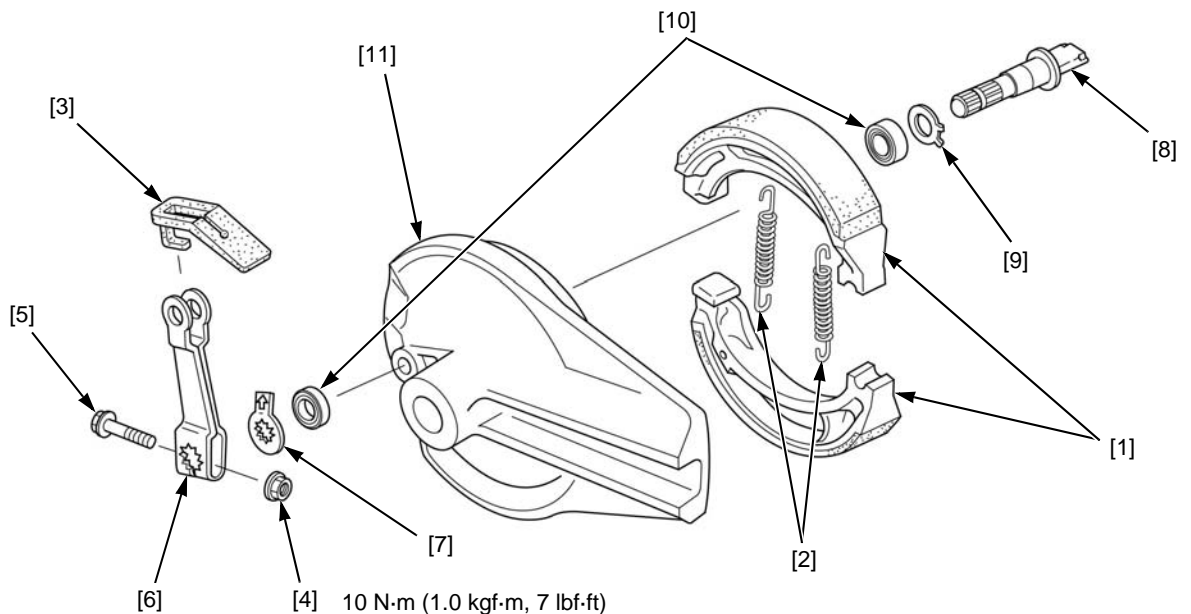

REAR WHEEL/BRAKE/SUSPENSION

ASSEMBLY

Apply grease to lips of new dust seals [1].

Install the dust seals with the flat surface facing out until they are seated.

Install the lock washer [2], aligning its tabs with the lug [3] on the brake panel.

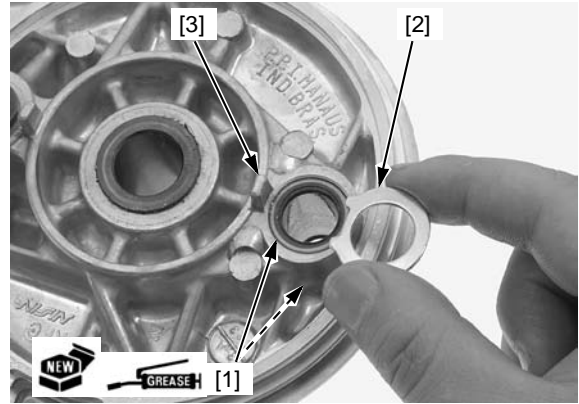

Apply grease to the spindle groove in the brake cam [1].
Insert the brake cam through the lock washer [2] and brake panel.

Install the indicator plate [3] by aligning the wide tooth with the wide groove in the brake cam.

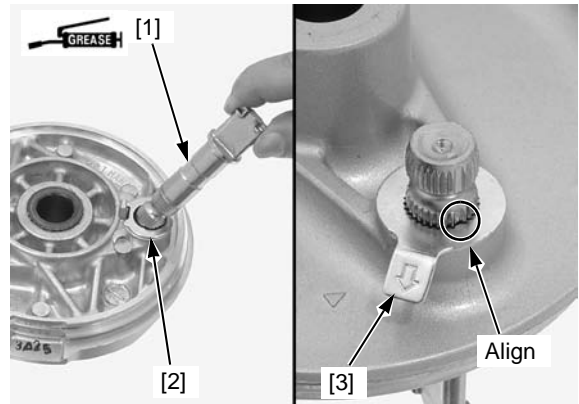

Install the brake arm [1] by aligning the punch marks [2].

Install the bolt [3] from the punch mark side and tighten the nut [4].

TORQUE: 10 N·m (1.0 kgf·m, 7 lbf·ft)

Install the arm cover [5] over the brake arm as shown.

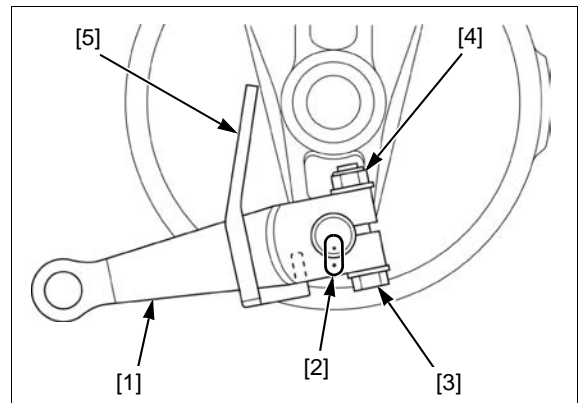

Apply grease to the anchor pin [1] and brake cam [2] sliding surfaces.

Assemble the brake shoes [3] and springs [4] as shown.

Install the shoe assembly onto the brake panel.

Wipe any excess grease from the brake cam and anchor pin.

Install the rear wheel (page 15-6).

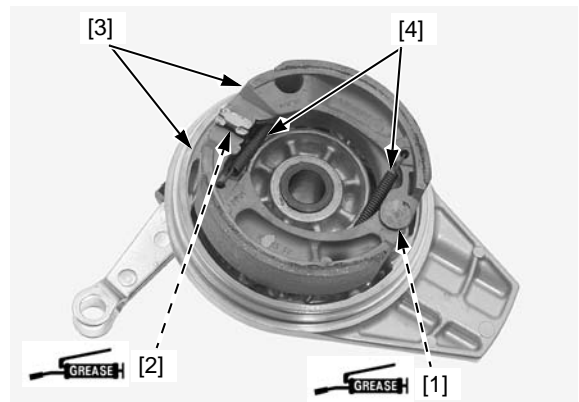

BRAKE PEDAL

REMOVAL

Remove the following:

- Brake adjusting nut [1]
- Brake rod [2] (from the joint pin)
- Rod spring [3]
- Joint pin [4]

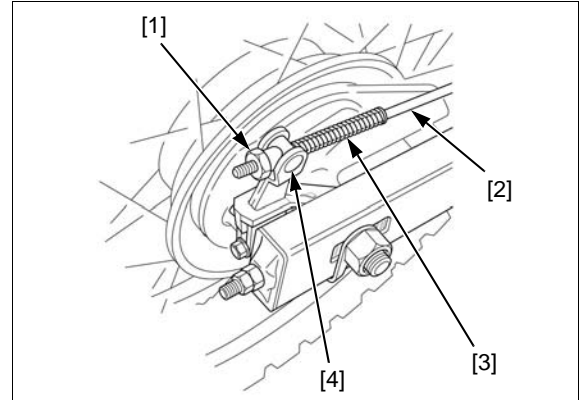

- Pedal return spring [1]
- Brake light switch spring [2]

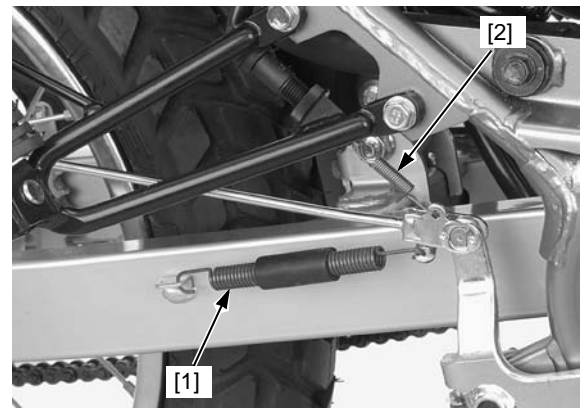

- Cotter pin [1]
- Washer [2]

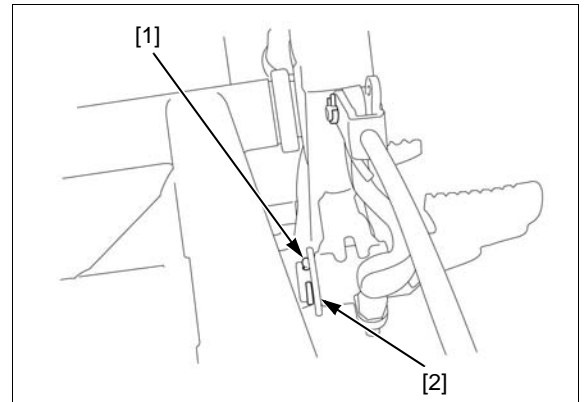

- Brake pedal [1]
- Dust seals [2]

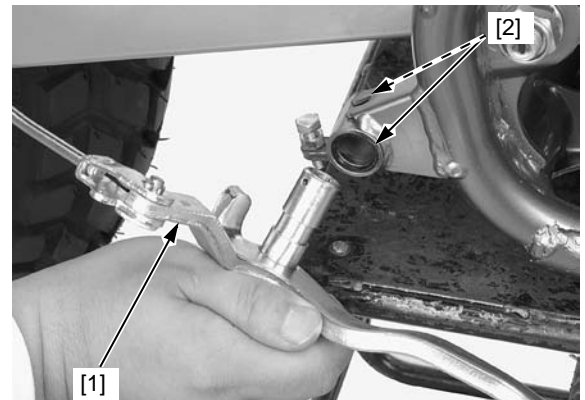

SHOCK ABSORBER

REMOVAL

Support the motorcycle securely with a hoist or an equivalent.

Remove the following:

- Seat (page 2-2)
- Left side cover (page 2-2)
- Rear wheel (page 15-4)

Remove the shock absorber lower mounting bolt [1] and nut [2].

Remove the shock absorber upper mounting bolt [3] and shock absorber [4].

Visually inspect the shock absorber for damage.

Check the following:

- Damper rod for bending or damage
 - Damper unit for deformation or oil leaks
 - Upper mount bush for wear or damage
- Do not disassemble the shock absorber.
 - Replace the shock absorber if any component is damaged.

Replace the shock absorber upper mounting bolt with new one.

Installation is in the reverse order of removal.

TORQUE:

- Upper mounting bolt:**
44 N-m (4.5 kgf-m, 33 lbf-ft)
- Lower mounting nut:**
44 N-m (4.5 kgf-m, 33 lbf-ft)

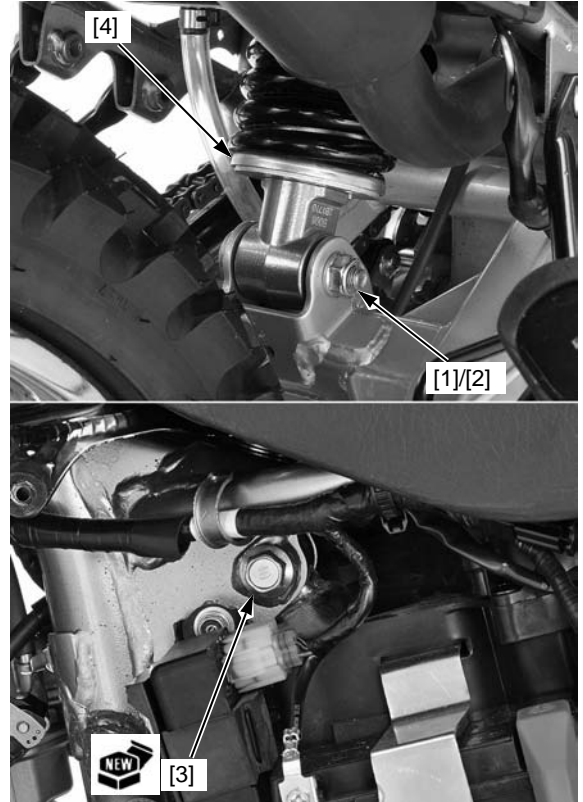

NEEDLE BEARING REPLACEMENT

Remove the collar [1] from the shock absorber.
Remove the dust seals [2].

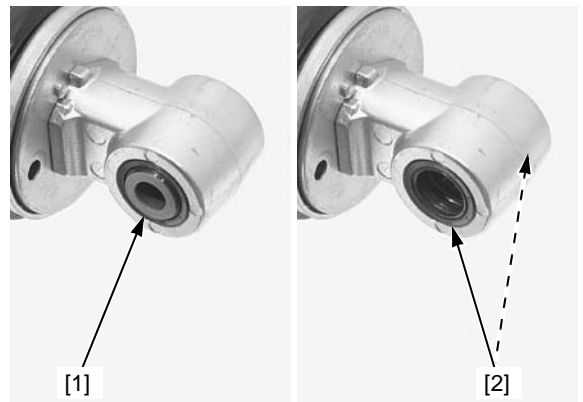

Press the needle bearing [1] out using the special tools and a hydraulic press.

TOOLS:

- [2] Driver shaft 07949-3710001
- [3] Attachment, 22 x 24 mm 07746-0010800
- [4] Pilot, 17 mm 07746-0040400

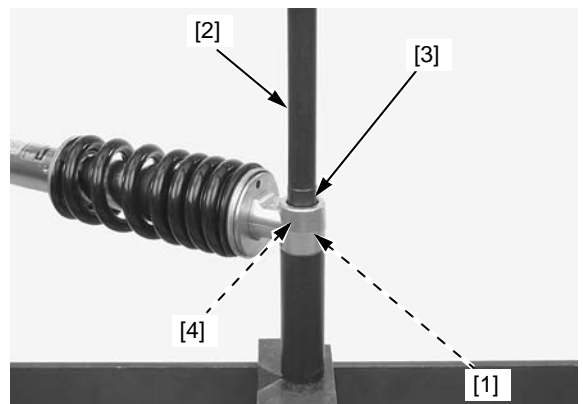

REAR WHEEL/BRAKE/SUSPENSION

Apply multi-purpose grease to needle rollers of a new bearing [1].

Press the needle bearing on the stamped side.

Press the needle bearings into the shock arm lower mount so that the needle bearing surface is lower 7.8 – 8.2 mm (0.31 – 0.32 in) from the end of the lower mount using the special tools and a hydraulic press.

TOOLS:

[2] Driver	07749-0010000
[3] Attachment, 24 x 26 mm	07746-0010700
[4] Pilot, 17 mm	07746-0040400

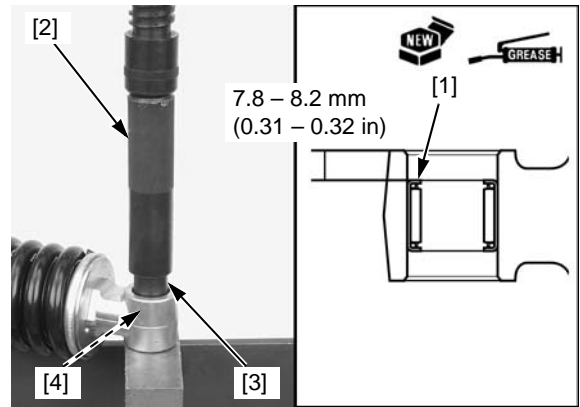

Apply grease to lips of a new dust seals [1] and the collar [2].
Install the dust seals into the shock absorber.
Install the collar.

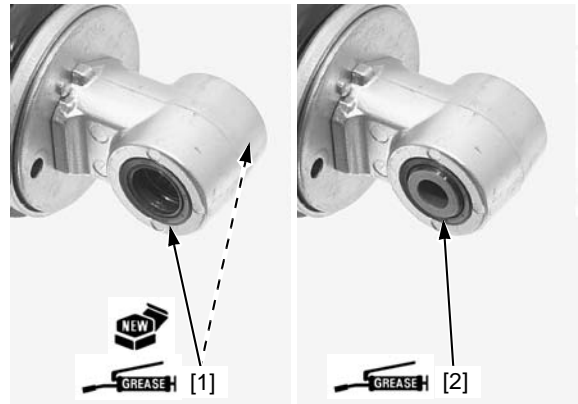

SHOCK ABSORBER DISPOSAL

Center punch the damper case to mark the drilling point.
(Refer to the right illustration).

DRILLING POINT: 30 mm (1.2 in) from pivot center

Wrap the shock absorber inside a plastic bag.
Support the shock absorber upright in a vise as shown.
Through the open end of the bag, insert a drill motor with a sharp 2 – 3 mm (5/64 – 1/8 in) drill bit.

- Do not use a dull drill bit which could cause a build-up of excessive heat and pressure inside the damper, leading to explosion and severe personal injury.
- The shock absorber contains nitrogen gas and oil under high pressure. Do not drill any further down the damper case than the measurement given above, or you may drill into the oil chamber; oil escaping under high pressure may cause serious personal injury.
- Always wear an eye protector to avoid getting metal shavings in your eyes when the gas pressure is released. The plastic bag is only intended to shield you from the escaping gas.

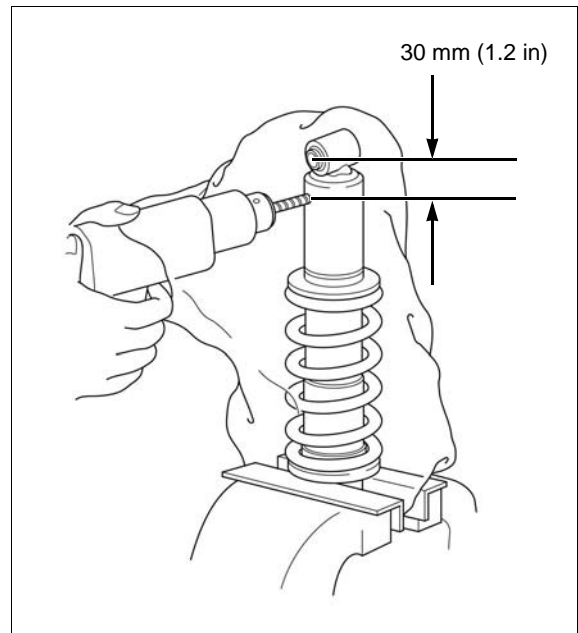

Hold the bag around the drill motor and briefly run the drill motor inside the bag; this will inflate the bag with air from the motor and help keep the bag from getting caught in the bit when you start.

SWINGARM

REMOVAL

Remove the drain plug [1] from the crankcase breather hose [2].
Remove the breather hose and carburetor drain hose [3] from the guide [4].

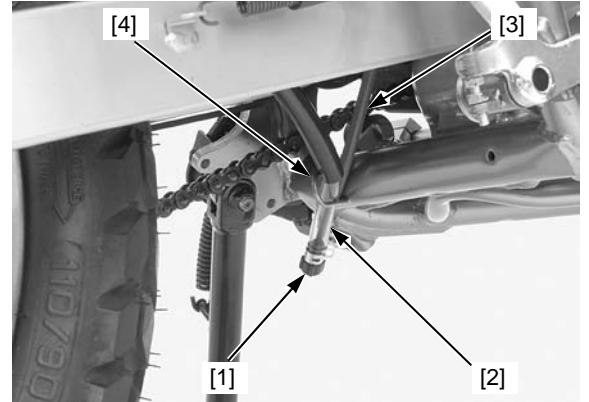

Remove the rear wheel (page 15-4).
Unhook the rear brake return spring [1].
Remove the shock absorber lower mount bolt [2] and nut [3].

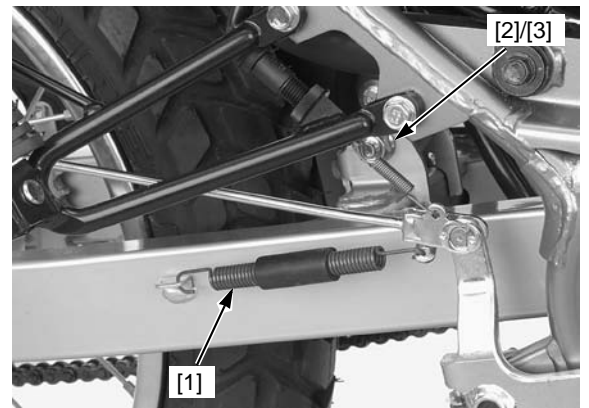

Remove the drive chain adjusters [1].

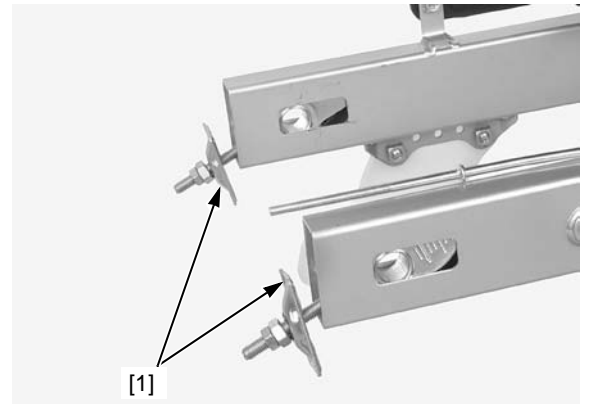

Remove the drive chain cover bolts [1] and collars [2].
Remove the drive chain cover [3].

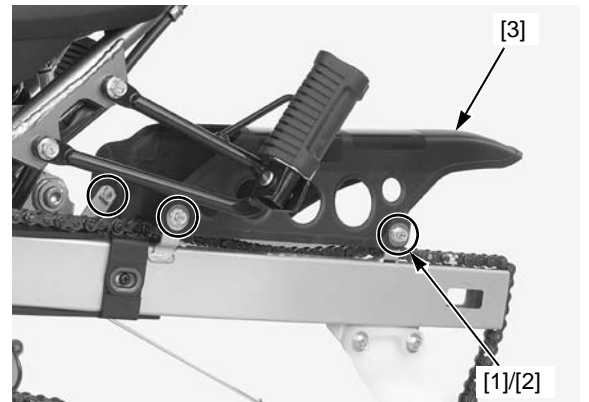

REAR WHEEL/BRAKE/SUSPENSION

Remove the swingarm pivot nut [1].
Remove the pivot bolt [2] from the left side and remove the swingarm [3].

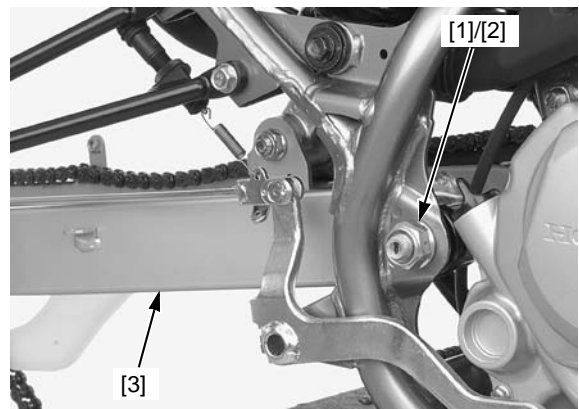

DISASSEMBLY/ASSEMBLY

Disassemble and assemble the swingarm as following illustration.

- Drive chain adjuster [1]
- Chain slider [4]
- Needle bearings [7]
- Screw [2]
- Dust seals [5]
- Swingarm [8]
- Collar [3]
- Distance collar [6]

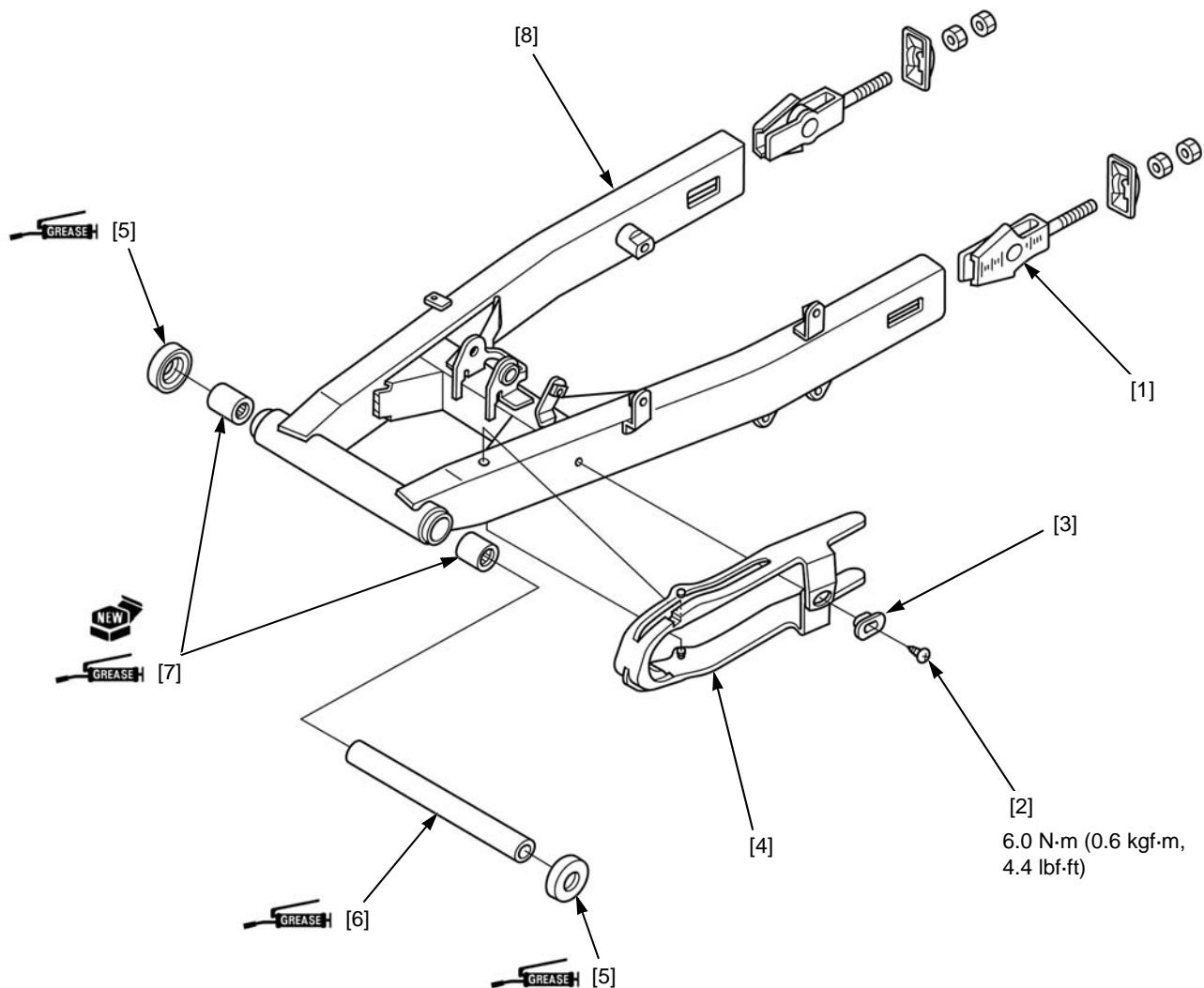

NEEDLE BEARING REPLACEMENT

Remove the drive chain guard bolts, collars and drive chain guard (page 15-14).

Remove the needle bearing [1] form the swingarm using the special tools.

TOOL:

- [2] Bearing remover set, 20 mm 07936-3710600
- [3] Bearing remover weight 07741-0010201
- Bearing remover handle 07936-3710100

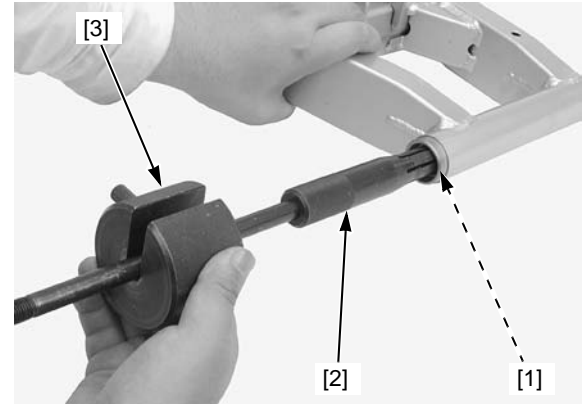

Apply grease to a new needle bearing [1].

Press the needle bearing on the stamped side.

Press the needle bearings into the swingarm pivot so that the needle bearing surface is lower 8.0 – 9.0 mm (0.31 – 0.35 in) from the end of the swingarm using the special tools and a hydraulic press.

TOOLS:

- [2] Driver 07749-0010000
- [3] Attachment, 24 x 26 mm 07746-0010700
- [4] Pilot, 20 mm 07746-0040500

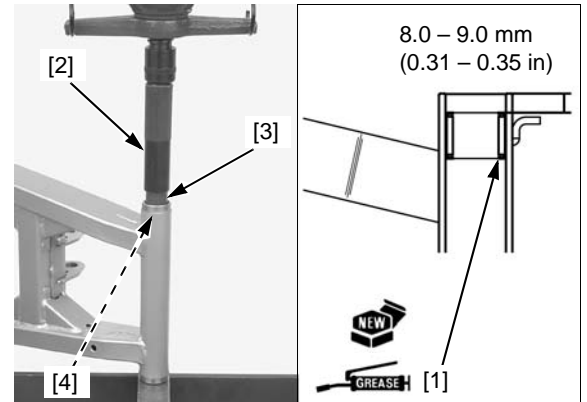

INSTALLATION

Install the swingarm [1] onto the frame.

Install the swingarm pivot bolt [2] to the frame from the left side.

Install and tighten the swingarm pivot nut [3] to the specified torque.

TORQUE: 88 N·m (9.0 kgf·m, 65 lbf·ft)

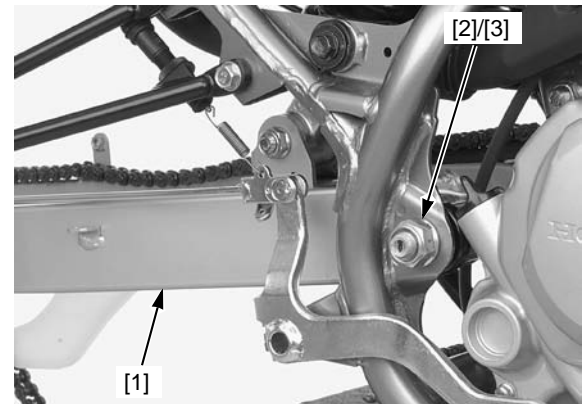

Install the drive chain cover [1] on the swingarm.

Install the drive chain cover collars [2] and bolts [3], then tighten the bolts.

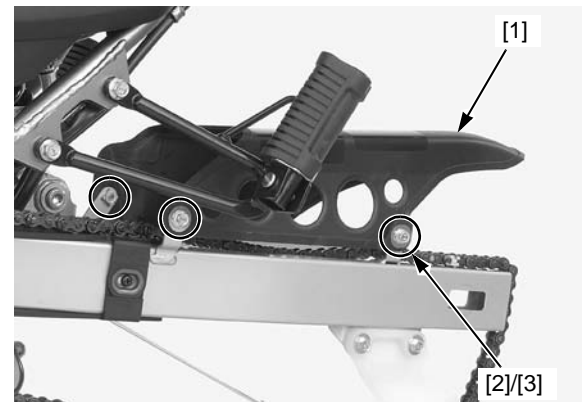

REAR WHEEL/BRAKE/SUSPENSION

Install the drive chain adjusters [1].

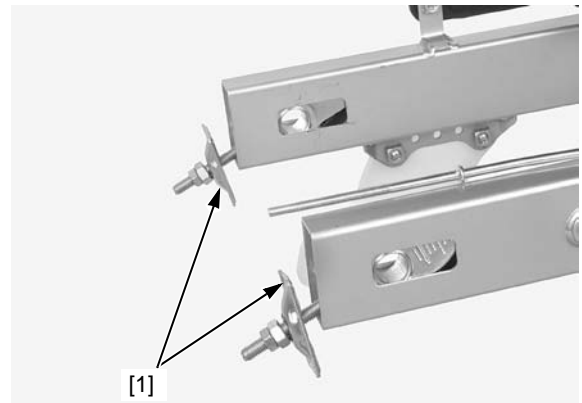

Install the rear wheel (page 15-6).

Install the shock absorber lower mount bolt [1] and nut [2].

Hook the rear brake return spring [3].

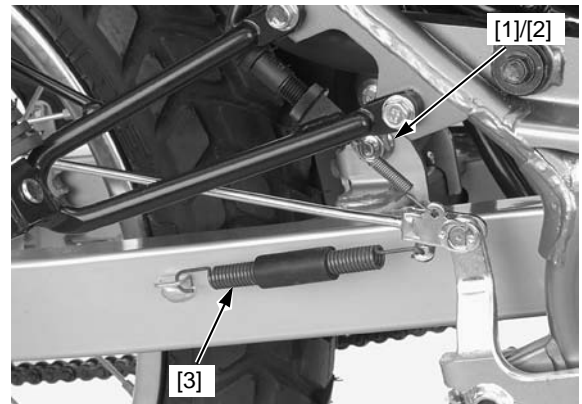

Install the carburetor drain hose [1] and crankcase breather hose [2] through the guide [3].
Install the drain plug [4] to the breather drain hose.

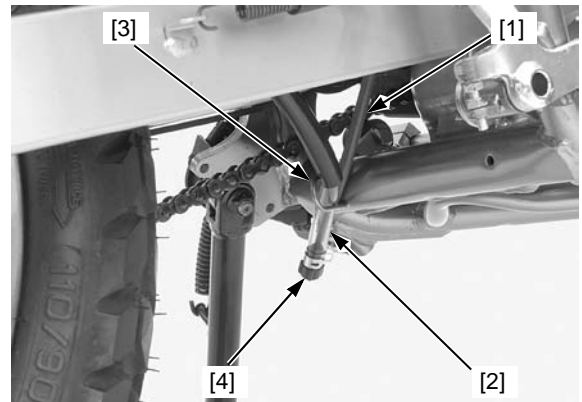

16. HYDRAULIC BRAKE (XR125LK/LEK)

SYSTEM COMPONENTS.....	16-2	BRAKE PAD/DISC.....	16-6
SERVICE INFORMATION.....	16-3	MASTER CYLINDER	16-7
TROUBLESHOOTING.....	16-3	BRAKE CALIPER	16-9
BRAKE FLUID REPLACEMENT/AIR BLEEDING.....	16-4		

SYSTEM COMPONENTS

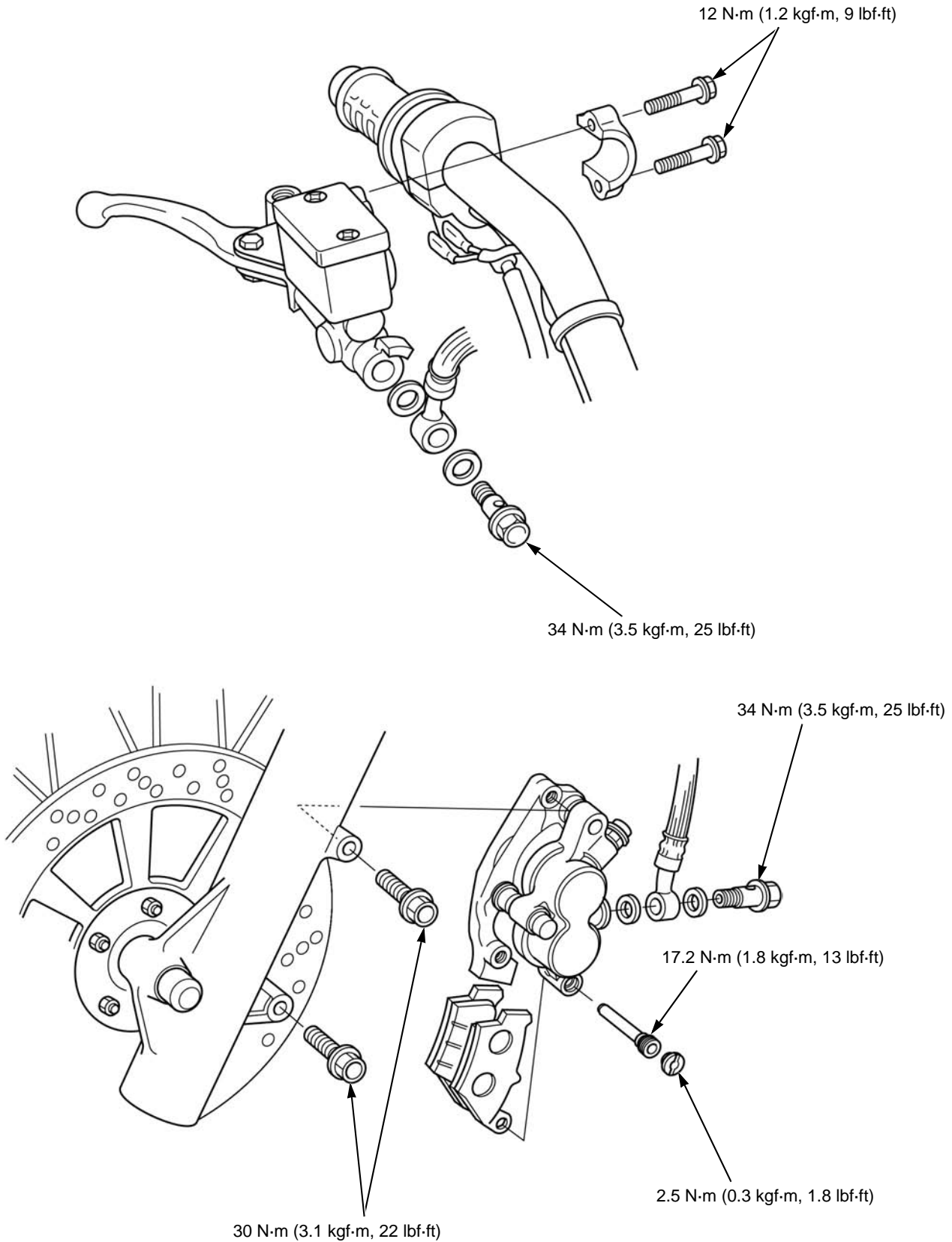

SERVICE INFORMATION

GENERAL

⚠ CAUTION

Frequent inhalation of brake pad dust, regardless of material composition, could be hazardous to your health.

- Avoid breathing dust particles.
- Never use an air hose or brush to clean brake assemblies. Use an OSHA-approved vacuum cleaner.

NOTICE

Avoid spilling fluid on painted, plastic, or rubber parts. Place a rag over these parts whenever the system is serviced. Brake fluid will damage these types of materials.

- A contaminated brake disc or pad reduces stopping power. Discard contaminated pads and clean a contaminated disc with a high quality brake degreasing agent.
- Check the brake system by applying the brake lever or pedal after the air bleeding.
- Never allow contaminants (dirt, water, etc.) to get into an open reservoir.
- Once the hydraulic system has been opened, or if the brake feels spongy, the system must be bled.
- Always use fresh DOT 3 or DOT 4 brake fluid from a sealed container when servicing the system. Do not mix different types of fluid, they may not be compatible.
- Always check brake operation before riding the motorcycle.

TROUBLESHOOTING

Brake lever soft or spongy

- Air in hydraulic system
- Leaking hydraulic system
- Contaminated brake pad/disc
- Worn caliper piston seal
- Worn master cylinder piston cups
- Worn brake pad/disc
- Contaminated caliper
- Contaminated master cylinder
- Caliper not sliding properly
- Low brake fluid level
- Clogged fluid passage
- Warped/deformed brake disc
- Sticking/worn caliper piston
- Sticking/worn master cylinder piston
- Bent brake lever

Brake lever hard

- Clogged/restricted brake system
- Sticking/worn caliper piston
- Worn caliper piston seal
- Sticking/worn master cylinder piston
- Bent brake lever

Brake drags

- Contaminated brake pad/disc
- Misaligned wheel
- Badly worn brake pad/disc
- Warped/deformed brake disc
- Caliper not sliding properly
- Clogged/restricted fluid passage
- Sticking caliper piston

HYDRAULIC BRAKE (XR125LK/LEK)

BRAKE FLUID REPLACEMENT/AIR BLEEDING

BRAKE FLUID DRAINING

Turn the handlebar until the reservoir is parallel to the ground before removing the reservoir cap.

Remove the screws [1], reservoir cap [2], set plate [3] and diaphragm [4].

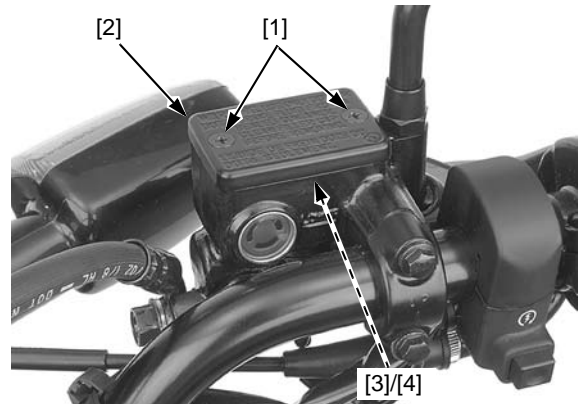

Connect a bleed hose [1] to the caliper bleed valve [2].

Loosen the bleed valve and pump the brake lever until no more fluid flows out of the bleed valve.

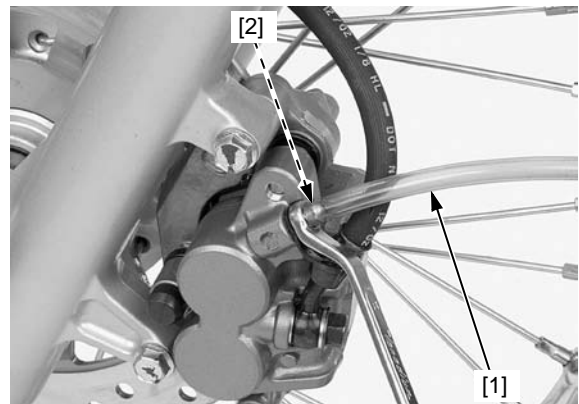

BRAKE FLUID FILLING/AIR BLEEDING

Fill the reservoir to the casting ledge [1] with DOT 3 or DOT 4 brake fluid from a sealed container.

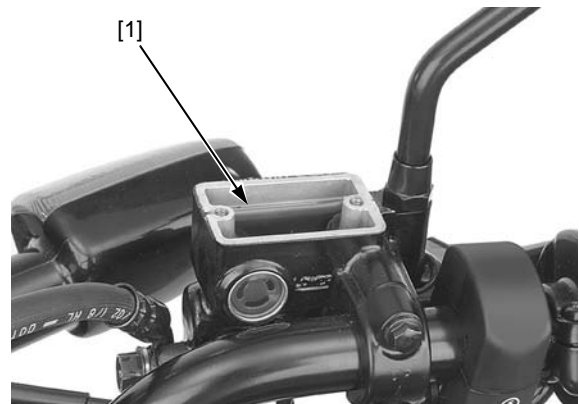

Connect a commercially available brake bleeder [1] to the bleed valve [2].

Operate the brake bleeder and loosen the bleed valve.

If an automatic refill system is not used, add fluid when the fluid level in the reservoir is low.

Perform the bleeding procedure until the system is completely flushed/bled.

Close the bleed valve and operate the brake lever. If it still feels spongy, bleed the system again.

If air enters the bleeder from around the bleed valve threads, seal the threads with teflon tape.

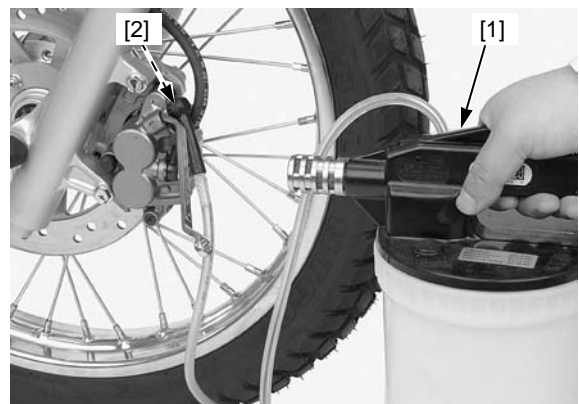

HYDRAULIC BRAKE (XR125LK/LEK)

If the brake bleeder is not available, perform the following procedure.

Pump up the system pressure with the brake lever [1] until the lever resistance is felt.

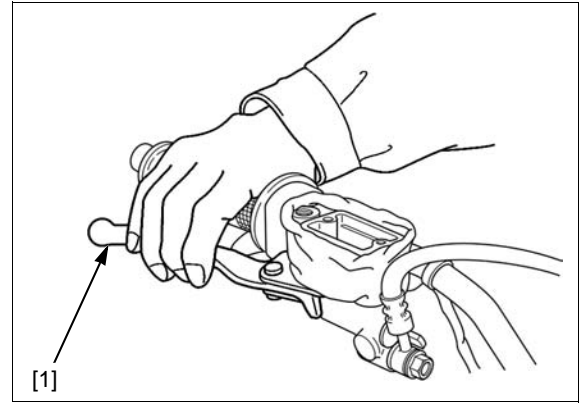

Do not release the brake lever until the bleed valve has been closed.

Connect a bleed hose [1] to the bleed valve [2] and bleed the system as follows:

1. Squeeze the brake lever all the way and loosen the bleed valve 1/2 of a turn. Wait several seconds and then close the bleed valve.
2. Release the brake lever slowly and wait several seconds after it reaches the end of its travel.
3. Repeat the steps 1 and 2 until there are no air bubbles in the bleed hose.

After bleeding the system completely, tighten the bleed valve.

TORQUE: 5.4 N·m (0.6 kgf·m, 4.0 lbf·ft)

Fill the reservoir to the casting ledge [1] with DOT 3 or DOT 4 brake fluid from a sealed container.

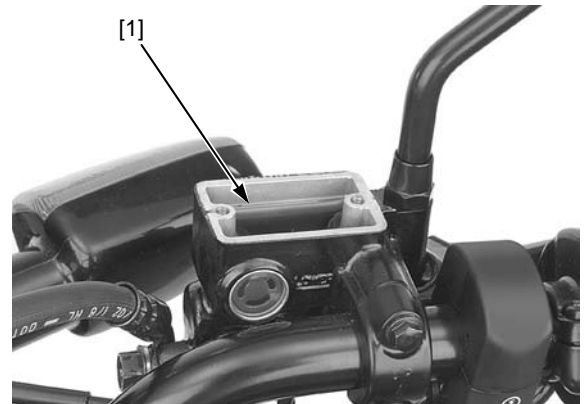
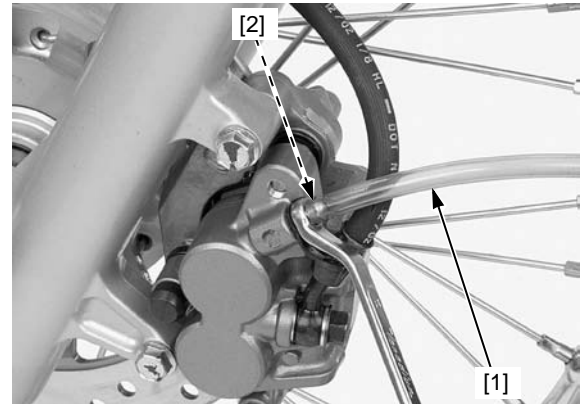

Install the diaphragm [1], set plate [2] and reservoir cap [3].

Install and tighten the screws [4] to the specified torque.

TORQUE: 1.5 N·m (0.2 kgf·m, 1.1 lbf·ft)

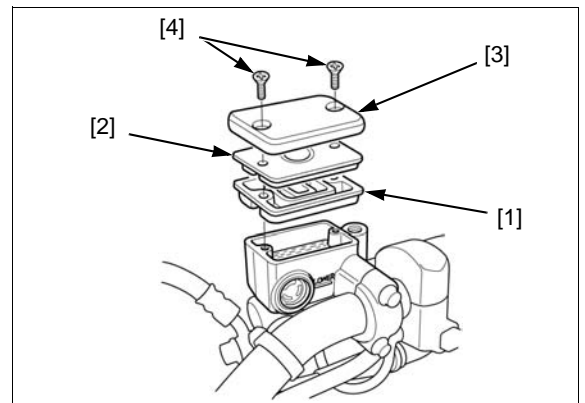

HYDRAULIC BRAKE (XR125LK/LEK)

BRAKE PAD/DISC

BRAKE PAD REPLACEMENT

Remove the pad pin plug [1] and loosen the pad pin [2].

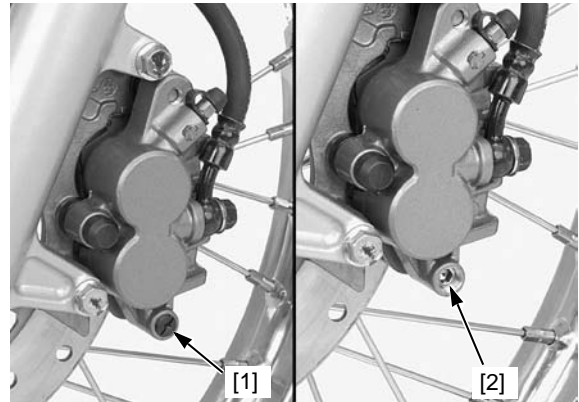

Remove the pad pin [1] while holding the brake pads [2], then remove the brake pads.

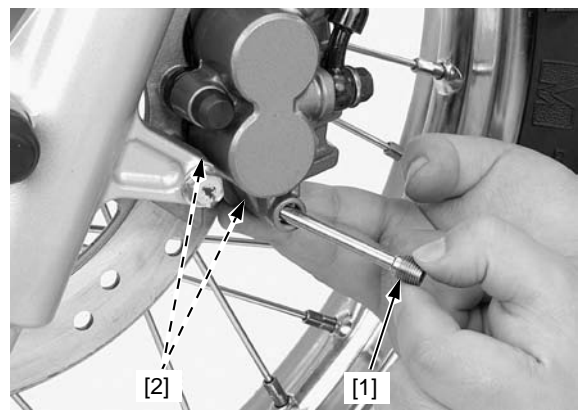

Make sure the pad spring is installed in position.

Install the brake pads [1] so that their ends rest on the pad retainer [2] on the caliper bracket properly.

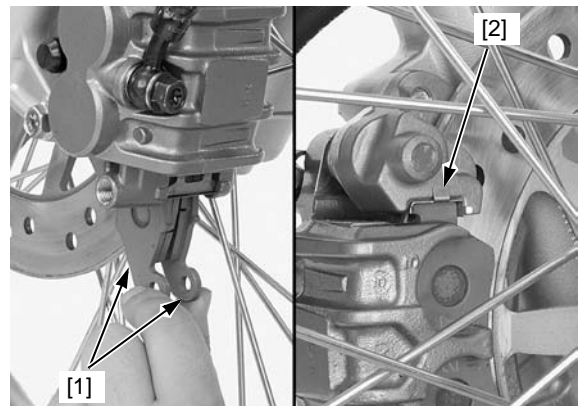

Install the pad pin [1] by pushing the pads against the pad spring to align the pad pin holes in the pads and caliper.

Tighten the pad pin.

TORQUE: 17.2 N·m (1.8 kgf·m, 13 lbf·ft)

Install and tighten the pad pin plug [2].

TORQUE: 2.5 N·m (0.3 kgf·m, 1.8 lbf·ft)

Operate the brake lever to seat the caliper pistons against the pads.

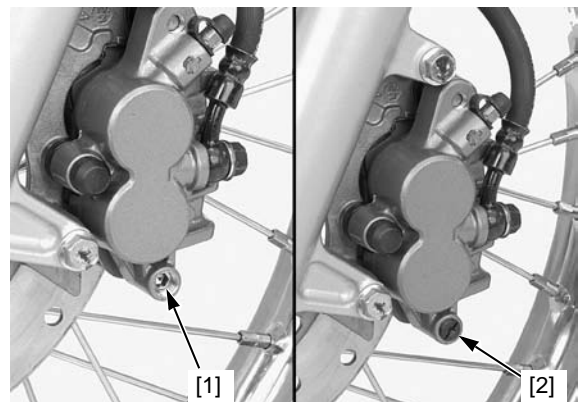

BRAKE DISC INSPECTION

Visually inspect the brake disc [1] for damage or crack.
Measure the brake disc thickness at several points.

SERVICE LIMIT: 3.5 mm (0.14 in)

Replace the brake disc if the smallest measurement is less than service limit.

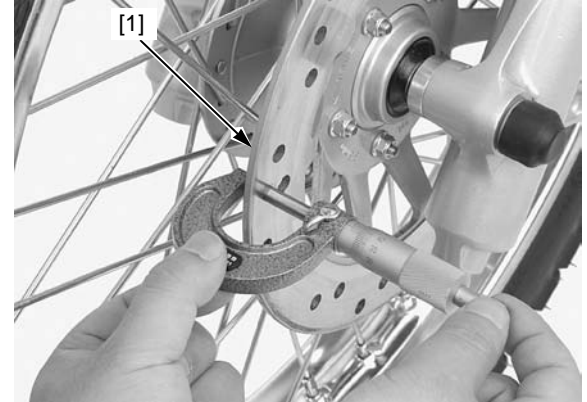

Check the brake disc for warpage.

SERVICE LIMIT: 0.25 mm (0.010 in)

Check the wheel bearings for excessive play, if the warpage exceeds the service limit.
Replace the brake disc if the wheel bearings are normal.



MASTER CYLINDER

REMOVAL/INSTALLATION

Drain the brake fluid from the hydraulic system (page 16-4).

Remove the rearview mirror.

Disconnect the brake hose [1] by removing the oil bolt [2] and sealing washers [3].

Disconnect the front brake light switch connectors [4].

Remove the master cylinder holder bolts [5], holder [6] and master cylinder [7].

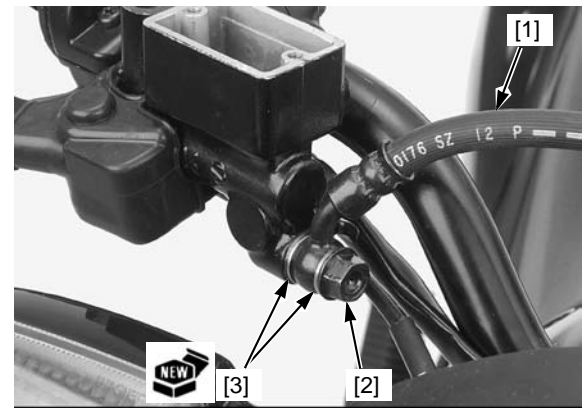

Install the master cylinder holder with its "UP" mark [8] facing up.

Install the master cylinder, holder and holder bolts.

Align the end of the master cylinder with the punch mark [9] on the handlebar, and tighten the upper bolt first, then tighten the lower bolt.

TORQUE: 12 N·m (1.2 kgf·m, 9 lbf·ft)

Connect the brake light switch connectors.

Connect the brake hose with the oil bolt and new sealing washers, and tighten the oil bolt.

TORQUE: 34 N·m (3.5 kgf·m, 25 lbf·ft)

Install the rearview mirror.

Fill and bleed the hydraulic system (page 16-4).

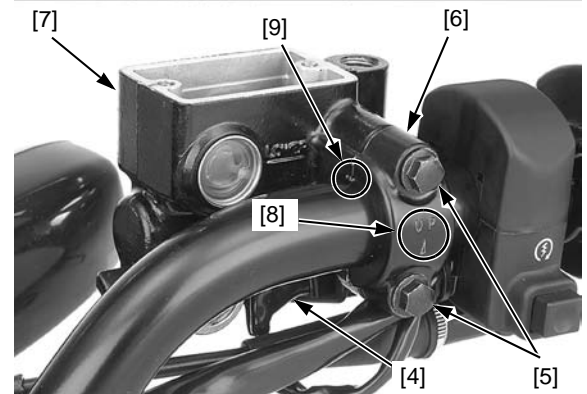

HYDRAULIC BRAKE (XR125LK/LEK)

DISASSEMBLY/ASSEMBLY

Disassemble and assemble the master cylinder as following illustration.

- | | | |
|--------------------|------------------------------|-------------------|
| - Nut [1] | - Brake lever pivot bolt [2] | - Brake lever [3] |
| - Screw [4] | - Brake light switch [5] | - Boot [6] |
| - Snap ring [7] | - Master piston [8] | - Spring [9] |
| - Piston cups [10] | - Reservoir cap [11] | - Set plate [12] |
| - Diaphragm [13] | - Screws [14] | |

- Keep the piston, cups, spring, snap ring, washer and boot as a set; do not substitute individual parts.
- When installing the piston, do not allow lips of the cups to turn inside out.
- Be sure that the snap ring is firmly seated in the groove.

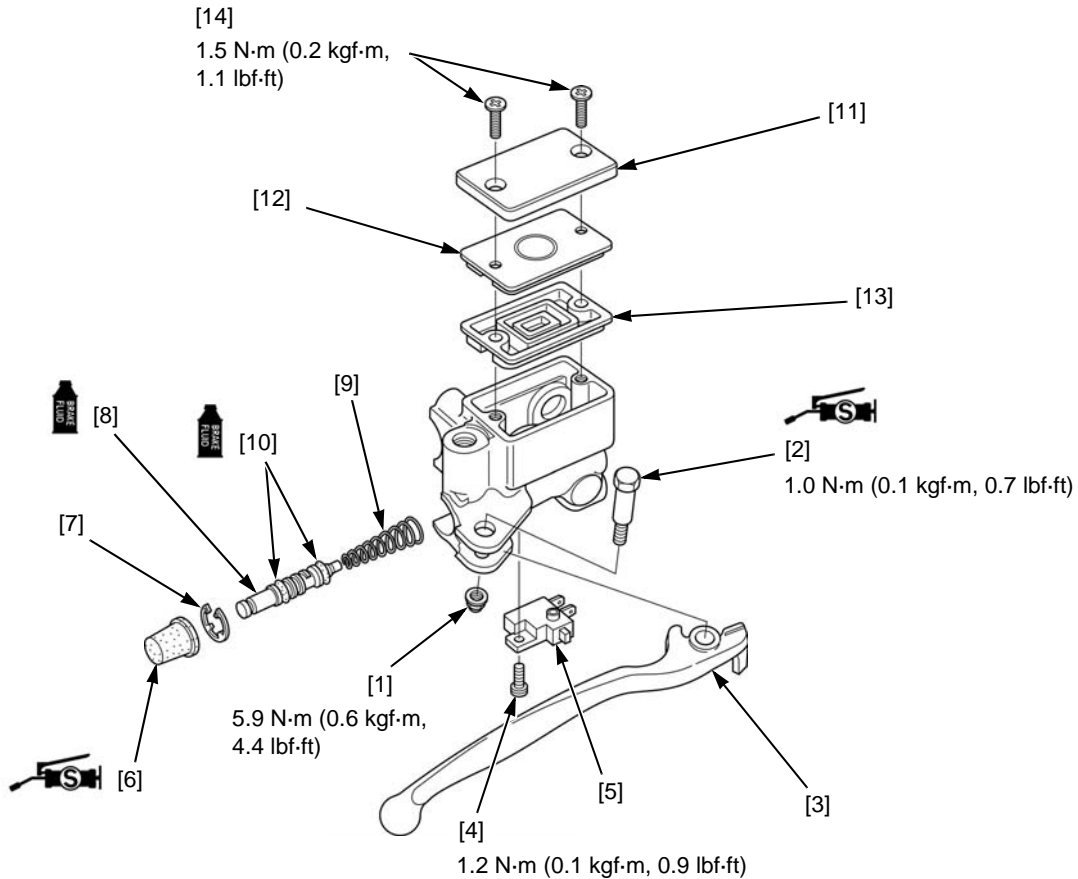

Remove and install the snap ring [1] using the special tool.

TOOL:
 [2] Snap ring pliers **07914-SA50001**

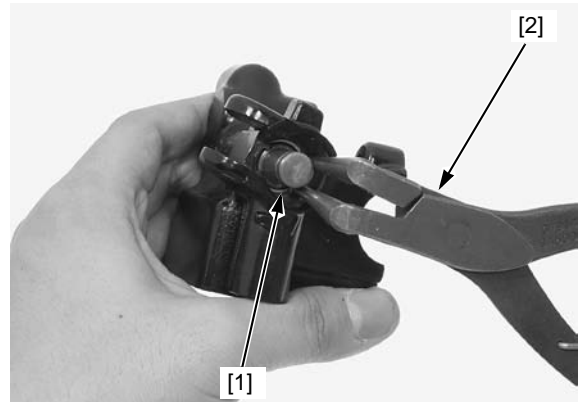

BRAKE CALIPER

REMOVAL/INSTALLATION

Drain the brake fluid (page 16-4).

Remove the following:

- Oil bolt [1]/brake hose [2]/sealing washers [3]
- Mounting bolts [4]
- Brake caliper [5]

Installation is in the reverse order of removal.

TORQUE:

Brake caliper mounting bolt:

30 N·m (3.1 kgf·m, 22 lbf·ft)

Brake hose oil bolt: 34 N·m (3.5 kgf·m, 25 lbf·ft)

- Replace the brake caliper mounting bolts and sealing washers with new ones.

Fill and bleed the hydraulic system (page 16-4).

DISASSEMBLY/ASSEMBLY

Remove the following:

- Pad pin plug [1]/pad pin [2]/brake pads [3] (page 16-6)
- Pad spring [4]
- Caliper bracket [5]/pad retainer [6]
- Bracket pin boot [7]
- Caliper pin boot [8]
- Bleed valve [9]/cap [10]

Do not use high pressure air or bring the nozzle too close to the inlet.

Position the caliper body [11] with the pistons down and apply small squirts of air pressure to the fluid inlet [12] to remove the pistons [13].

Remove the dust seals [14] and piston seals [15].

Assembly is in the reverse order of disassembly.

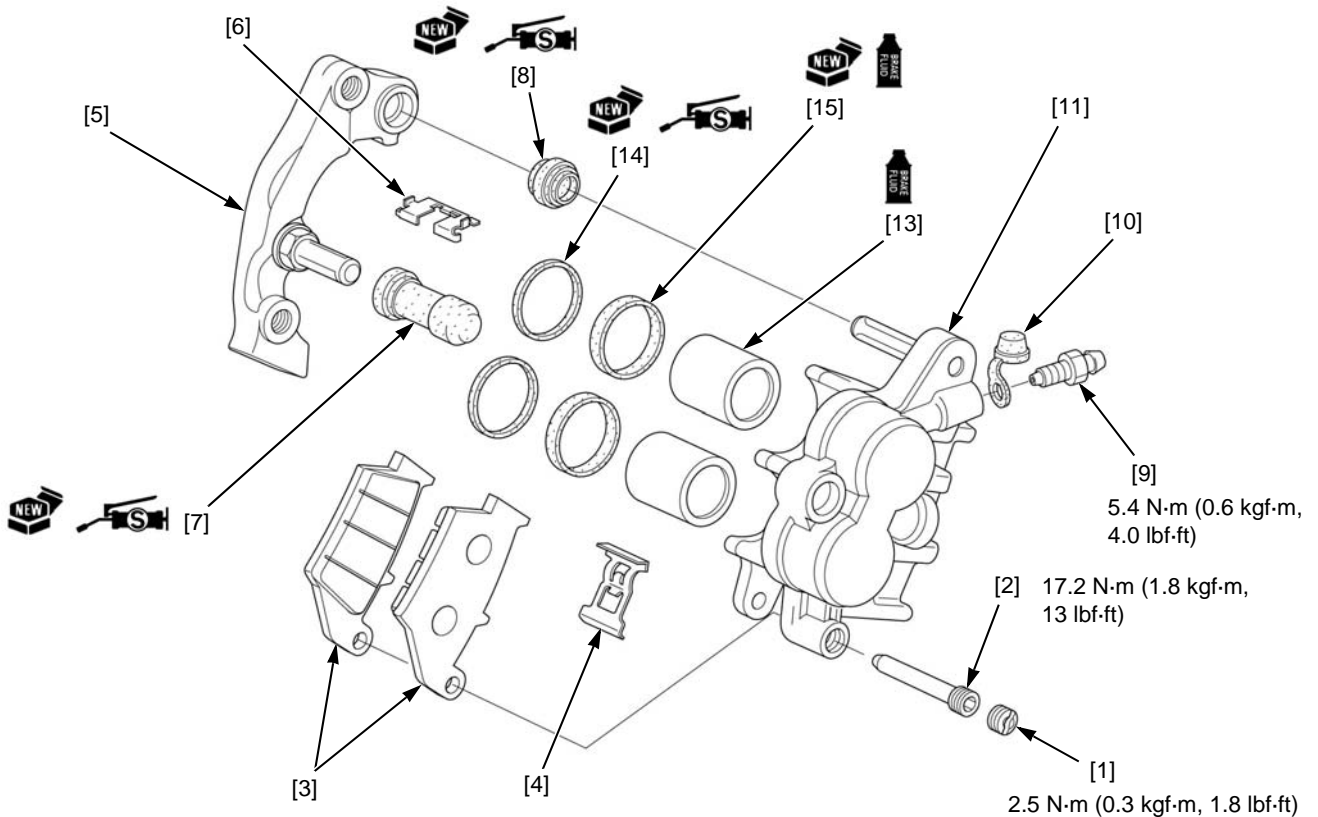
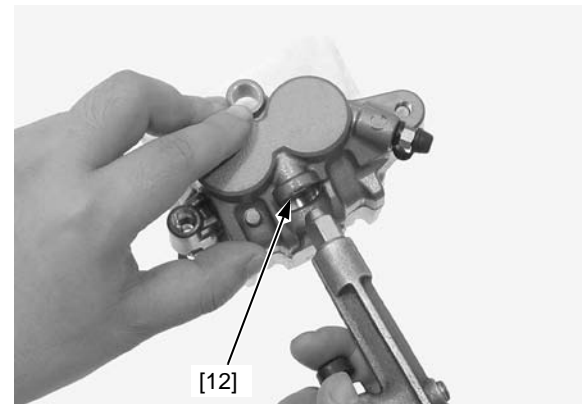
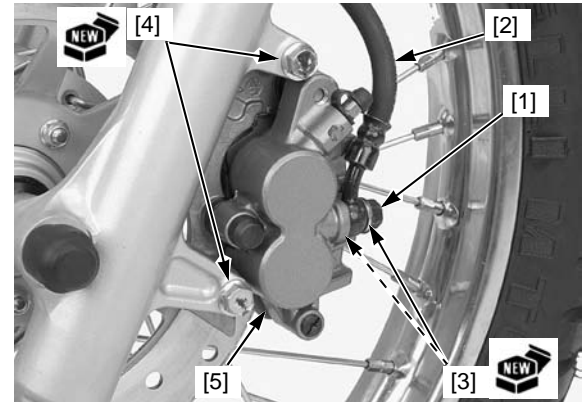

MEMO

17. BATTERY/CHARGING SYSTEM

COMPONENT LOCATION	17-2	BATTERY	17-5
SYSTEM DIAGRAM	17-2	CHARGING SYSTEM INSPECTION	17-6
SERVICE INFORMATION	17-3	REGULATOR/RECTIFIER	17-7
TROUBLESHOOTING.....	17-4	ALTERNATOR CHARGING COIL	17-7

BATTERY/CHARGING SYSTEM

COMPONENT LOCATION

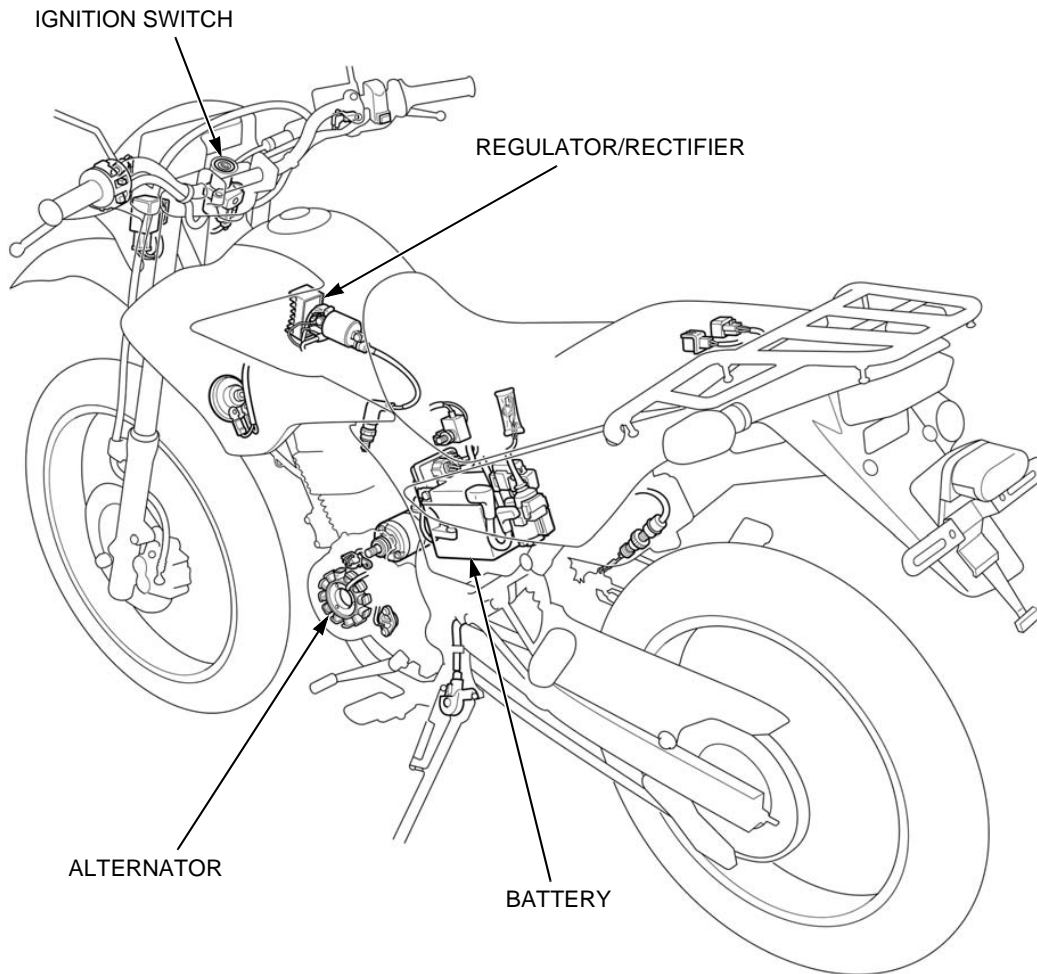

SYSTEM DIAGRAM

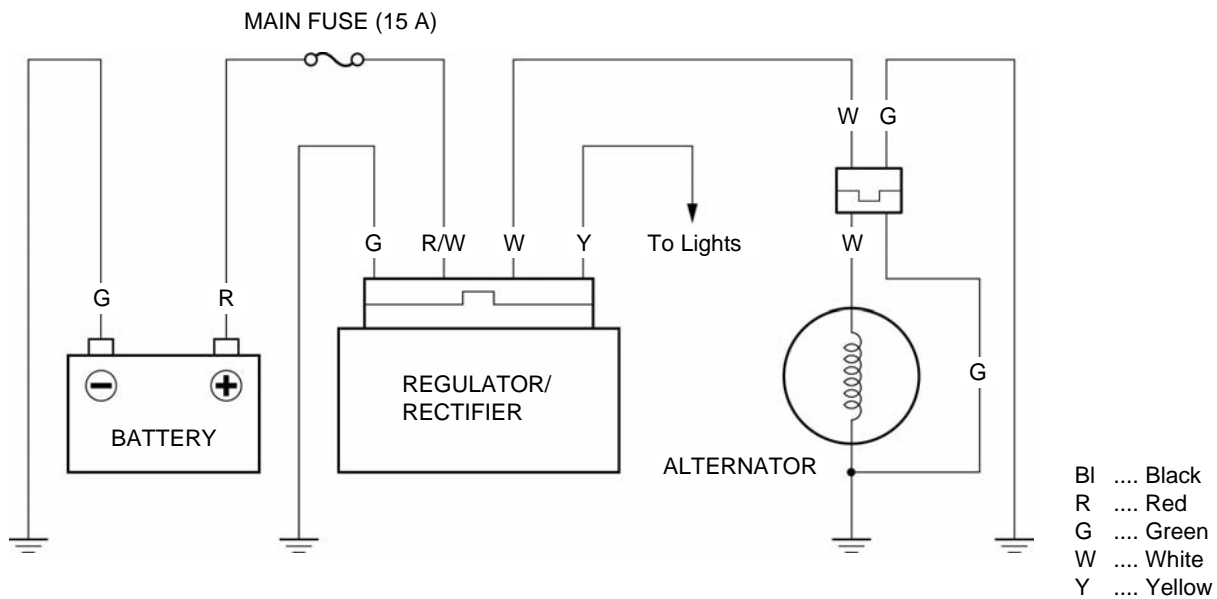

SERVICE INFORMATION

GENERAL

⚠ WARNING

- The battery gives off explosive gases; keep sparks, flames and cigarettes away. Provide adequate ventilation when charging.
- The battery contains sulfuric acid (electrolyte). Contact with skin or eyes may cause severe burns. Wear protective clothing and a face shield.
 - If electrolyte gets on your skin, flush with water.
 - If electrolyte gets in your eyes, flush with water for at least 15 minutes and call a physician immediately.
- Electrolyte is poisonous.
 - If swallowed, drink large quantities of water or milk and call your local Poison Control Center or a physician immediately.

NOTICE

- *Always turn OFF the ignition switch before disconnecting any electrical component.*
- *Some electrical components may be damaged if terminals or connectors are connected or disconnected while the ignition switch is ON and current is present.*
- For extended storage, remove the battery, give it a full charge, and store it in a cool, dry space. For maximum service life, charge the stored battery every two weeks.
- For a battery remaining in a stored motorcycle, disconnect the negative battery cable from the battery terminal.
- The maintenance free battery must be replaced when it reaches the end of its service life.
- The battery can be damaged if overcharged or undercharged, or if left to discharge for a long period. These same conditions contribute to shortening the life span of the battery. Even under normal use, the performance of the battery deteriorates after 2 – 3 years.
- Battery voltage may recover after battery charging, but under heavy load, battery voltage will drop quickly and eventually die out. For this reason, the charging system is often suspected as the problem. Battery overcharge often results from problems in the battery itself, which may appear to be an overcharging symptom. If one of the battery cells is shorted and battery voltage does not increase, the regulator/rectifier supplies excess voltage to the battery. Under these conditions, the electrolyte level goes down quickly.
- Before troubleshooting the charging system, check for proper use and maintenance of the battery. Check if the battery is frequently under heavy load, such as having the headlight and taillight ON for long periods of time without riding the motorcycle.
- The battery will self-discharge when the motorcycle is not in use. For this reason, charge the battery every 2 weeks to prevent sulfation from occurring.
- When checking the charging system, always follow the steps in the troubleshooting flow chart (page 17-4).
- For battery charging, do not exceed the charging current and time specified on the battery. Use of excessive current or charging time may damage the battery.

BATTERY CHARGING

- Turn power ON/OFF at the charger, not at the battery terminal.
- For battery charging, do not exceed the charging current and time specified on the battery. Using excessive current or extending the charging time may damage the battery.
- Quick charging should only be done in an emergency; slow charging is preferred.

BATTERY TESTING

Refer to the instruction of the Operation Manual for the recommended battery tester. The recommended battery tester puts a "load" on the battery so the actual battery condition of the load can be measured.

Recommended battery tester: BM-210, BATTERY MATE or equivalent

TROUBLESHOOTING

BATTERY IS DAMAGED OR WEAK

1. BATTERY TEST

Remove the battery (page 17-5).

Check the battery condition using the recommended battery tester.

RECOMMENDED BATTERY TESTER: BM-210 or equivalent

Is the battery in good condition?

NO – Faulty battery.

YES – GO TO STEP 2.

2. CURRENT LEAKAGE TEST

Install the battery (page 17-5).

Check the battery current leakage test (page 17-6).

Is the current leakage below 0.01 mA?

YES – GO TO STEP 4.

NO – GO TO STEP 3.

3. CURRENT LEAKAGE TEST WITHOUT REGULATOR/RECTIFIER CONNECTOR

Disconnect the regulator/rectifier connector and recheck the battery current leakage.

Is the current leakage below 0.01 mA?

YES – Faulty regulator/rectifier

NO –

- Shorted wire harness
- Faulty engine stop switch

4. ALTERNATOR CHARGING COIL INSPECTION

Check the alternator charging coil (page 17-7).

Is the alternator charging coil resistance within 0.2 – 1.2 Ω (20°C/68°F)?

NO – Faulty charging coil.

YES – GO TO STEP 5.

5. CHARGING VOLTAGE INSPECTION

Measure and record the battery voltage using a digital multimeter (page 17-6).

Start the engine.

Measure the charging voltage page 17-6.

Compare the measurements to the results of the following calculation.

STANDARD:

Measured battery Voltage < Measured charging voltage < 15.5 V

Is the measured charging voltage within the standard voltage?

YES – Faulty battery

NO – GO TO STEP 6.

6. REGULATOR/RECTIFIER SYSTEM INSPECTION

Check the voltage and resistance at the regulator/rectifier connector (page 17-7).

Are the measurements correct?

YES – Faulty regulator/rectifier

NO –

- Open circuit in related wire
- Loose or poor contacts of related terminal
- Shorted wire harness

BATTERY

REMOVAL/INSTALLATION

Remove the left side cover (page 2-2).

Remove the bolt [1], collar [2] and battery holder [3].
 Disconnect the negative (-) cable [4] first, and then the positive (+) cable [5].
 Remove the battery [6].

Install the battery in the reverse order of removal.

- Connect the positive terminal first and then the negative cable.

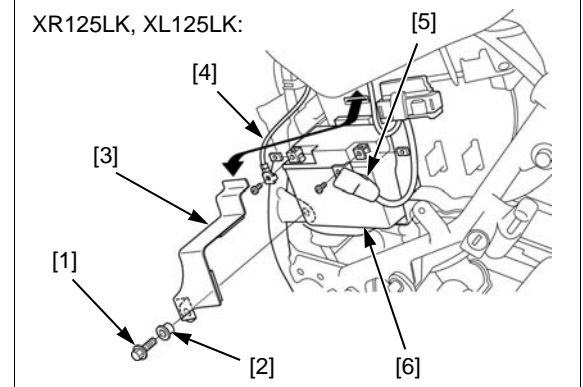
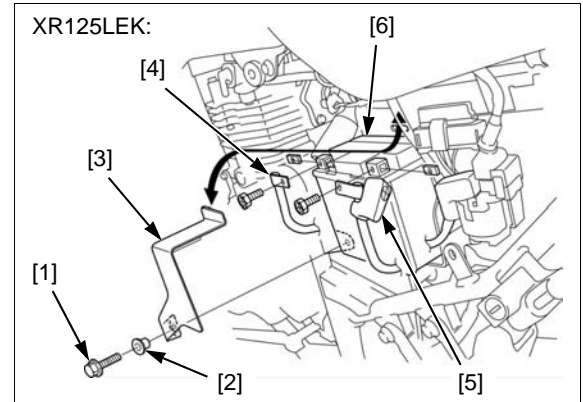

VOLTAGE INSPECTION

Measure the battery voltage using a commercially available digital multimeter.

VOLTAGE:

Fully charged: Above 12.8 V

Under charged: Below 12.3 V

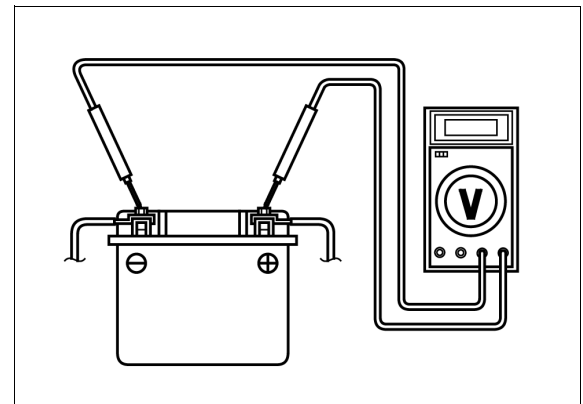

BATTERY CHARGING

- Quick charging should only be done in an emergency; slow charging is preferred.
- For battery charging, do not exceed the charging current and time specified on the battery. Using excessive current or extending the charging time may damage the battery.

Remove the battery (page 17-5).

*Turn power ON/
 OFF at the charger,
 not at the battery
 terminals.*

Connect the charger positive (+) cable to the battery positive (+) terminal.

Connect the charger negative (-) cable to the battery negative (-) terminal.

CHARGING CURRENT/TIME:

XR125LEK:

Normal: 0.5 A x 5 – 10 h

Quick: 5.0 A x 0.5 h

XL125LK, XR125LK:

Normal: 0.4 A x 5 – 10 h

Quick: 4.0 A x 0.5 h

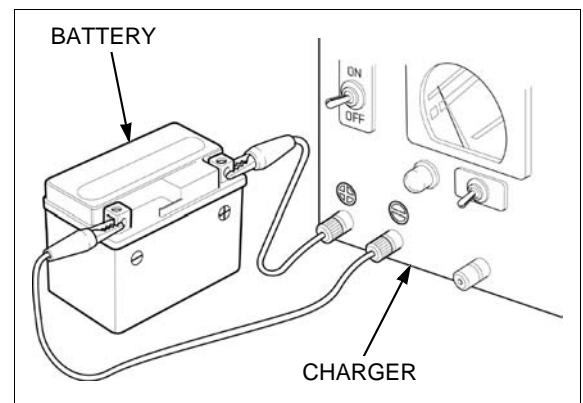

CHARGING SYSTEM INSPECTION

CURRENT LEAKAGE INSPECTION

Remove the left side cover (page 2-2).

With the ignition switch turned to "OFF", disconnect the negative (-) cable from the battery.

Connect the ammeter (+) probe to the negative (-) cable and the ammeter (-) probe to the battery (-) terminal.

With the ignition switch turned to "OFF", check for current leakage.

- When measuring current using a tester, set it to a high range, and then bring the range down to an appropriate level. Current flow higher than the range selected may blow the fuse in the tester.
- While measuring current, do not turn the ignition switch to "ON". A sudden surge of current may blow the fuse in the tester.

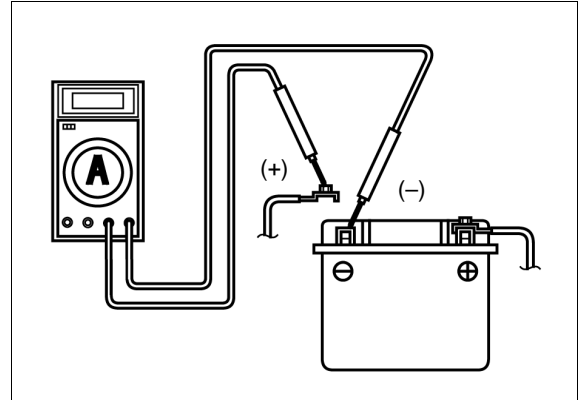

SPECIFIED CURRENT LEAKAGE: 0.01 mA max.

If current leakage exceeds the specified value, a shorted circuit is likely.

Locate the short by disconnecting connections one by one and measuring the current.

CHARGING VOLTAGE INSPECTION

Remove the left side cover (page 2-2).

Be sure the battery is in good condition before performing this test.

Warm up the engine to normal operating temperature. Connect the multimeter between the battery positive (+) and negative (-) terminals.

NOTICE

- To prevent a short, make absolutely certain which are the positive (+) and negative (-) terminals or cables.
- Do not disconnect the battery or any cable in the charging system without first turning the ignition switch to "OFF". Failure to follow this precaution can damage the tester or electrical components.

Measure the voltage on the multimeter when the engine runs at 5,000 min⁻¹ (rpm).

Standard: Measured battery voltage < Measured charging voltage < 15.5 V at 5,000 min⁻¹ (rpm)

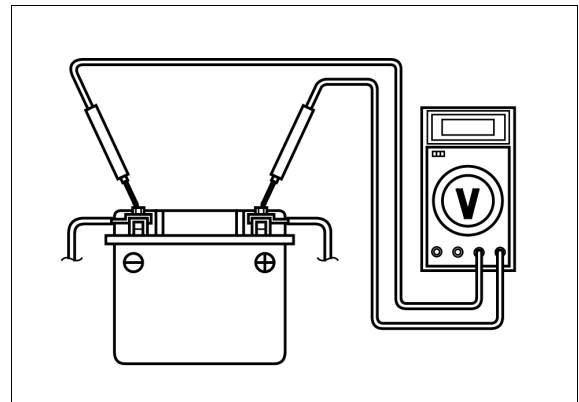

REGULATOR/RECTIFIER

SYSTEM INSPECTION

Remove the fuel tank (page 2-4).

Check the regulator/rectifier 4P connector [1] for loose contact or corroded terminals.

If the charging voltage reading (page 17-6) is out of the specification, check the following at the wire harness side connector.

Item	Terminal	Specification
Battery charging line	Red/white (+) and Ground (-)	Battery voltage should appear
Charging coil line	White and Green	0.2 – 1.2 Ω (at 20°C/68°F)
Ground line	Green and Ground	Continuity should exist

If all components of the charging system is normal and there are no loose connections at the regulator/rectifier 4P connector, replace the regulator/rectifier unit.

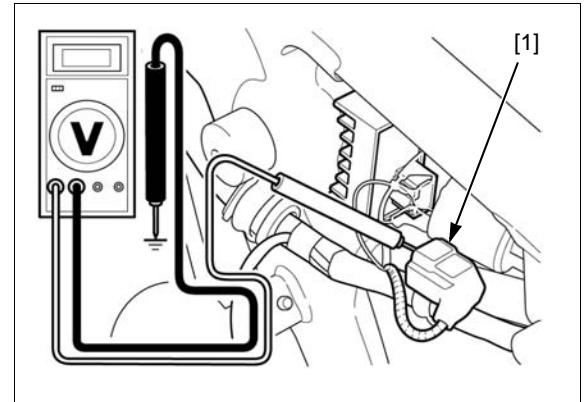

REMOVAL/INSTALLATION

Remove the fuel tank (page 2-4).

Disconnect the regulator/rectifier 4P connector [1].

Remove the bolts [2] and regulator/rectifier [3] from the frame.

Install the regulator/rectifier in the reverse order of removal.

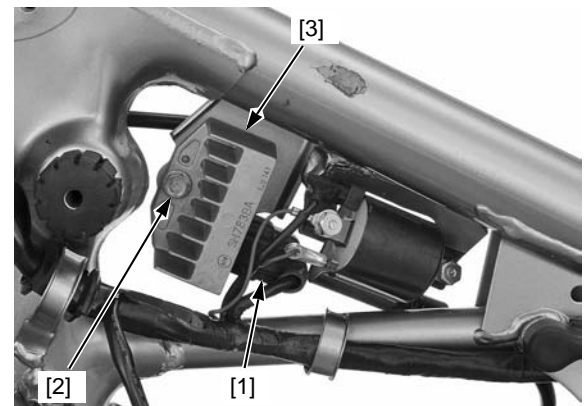

ALTERNATOR CHARGING COIL

INSPECTION

Remove the left side cover (page 2-2).

Disconnect the alternator 2P connector [1]. Measure the resistance between each wire terminal of the alternator.

Charging coil line

CONNECTION: White – Green

STANDARD: 0.2 – 1.2 Ω (20°C/68°F)

Replace the alternator stator if resistance is out of specification.

Refer to procedure for alternator stator replacement (page 11-4).

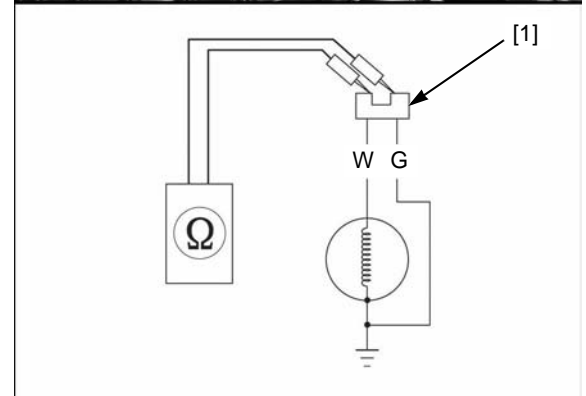
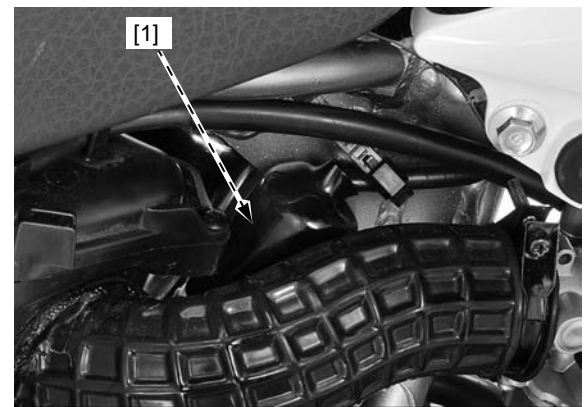

MEMO

18. LIGHTS/METER/SWITCHES

COMPONENT LOCATION	18-2	IGNITION SWITCH.....	18-7
SERVICE INFORMATION	18-2	HANDLEBAR SWITCHES	18-7
LIGHTING SYSTEM INSPECTION	18-3	BRAKE LIGHT SWITCHES	18-8
HEADLIGHT/POSITION LIGHT	18-4	CLUTCH SWITCH.....	18-9
BRAKE/TAIL LIGHT.....	18-4	NEUTRAL SWITCH	18-9
LICENSE LIGHT (XR125LK/LEK)	18-5	SIDESTAND SWITCH (NZ TYPE)	18-10
TURN SIGNAL LIGHTS	18-5	TURN SIGNAL RELAY	18-11
COMBINATION METER.....	18-6	HORN	18-11

COMPONENT LOCATION

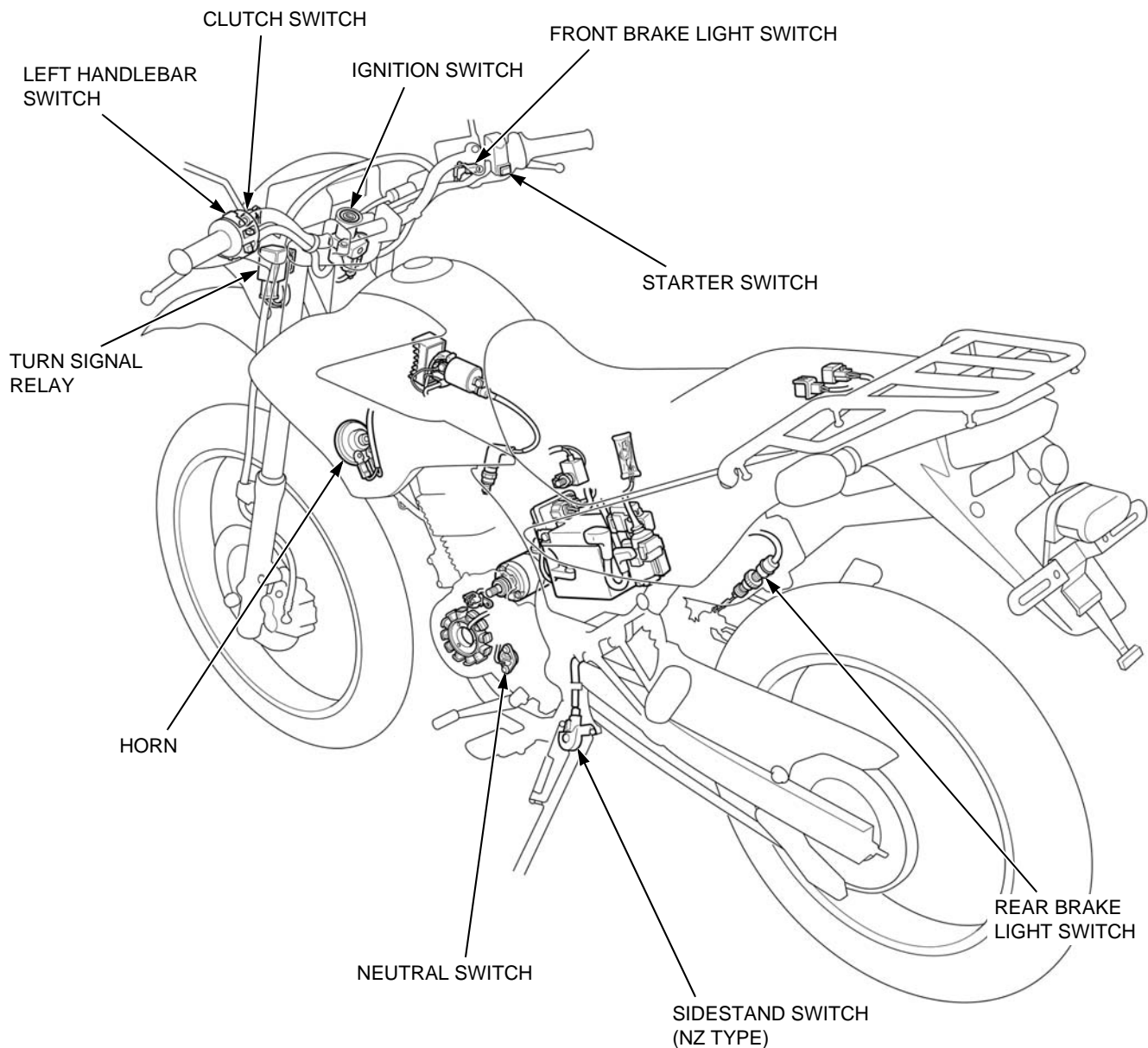

SERVICE INFORMATION

GENERAL

- A halogen headlight bulb becomes very hot while the headlight is "ON", and remains hot for a while after it is turned "OFF". Be sure to let it cool down before servicing.
- Keep all flammable materials away from the electric heating element. Wear protective clothing, insulated gloves and eye protection.
- Note the following when replacing the halogen headlight bulb.
 - Wear clean gloves while replacing the bulb. Do not put finger prints on the headlight bulb, as they may create hot spots on the bulb and cause it to fail.
 - If you touch the bulb with your bare hands, clean it with a cloth moistened with alcohol to prevent its early failure.
 - Be sure to install the dust cover after replacing the bulb.
- Check the battery condition before performing any inspection that requires proper battery voltage.
- A continuity test can be made with the switches installed on the motorcycle.

LIGHTING SYSTEM INSPECTION

HEADLIGHT DOES NOT COME ON OR IS WEAK

Standard Inspection

Check the following:

- Burned out bulb or bulb with unspecified wattage
- Loose connector
- Dimmer switch

If the above items are normal, check as follows:

Lighting Circuit Inspection

Remove the front visor (page 2-4).

Disconnect the regulator/rectifier 4P (Black) connector (page 17-7).

Turn the dimmer switch [1] to Hi position.

Check the continuity between the Blue terminal of the headlight 4P connector [2] and Yellow terminal of the regulator/rectifier 4P connector [3].

Turn the dimmer switch to Lo position.

Check the continuity between the White terminal of the headlight 4P connector and Yellow terminal of the regulator/rectifier 4P connector.

If there is continuity, check the following:

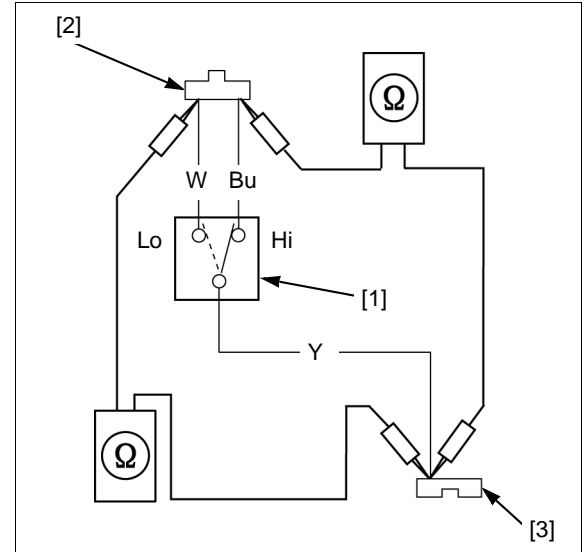

Ground Inspection

Check the continuity between the Green terminal of the headlight 4P connector [1] and ground.

If there is continuity, check the regulator/rectifier (page 17-7).

Install the removed parts in the reverse order of removal.

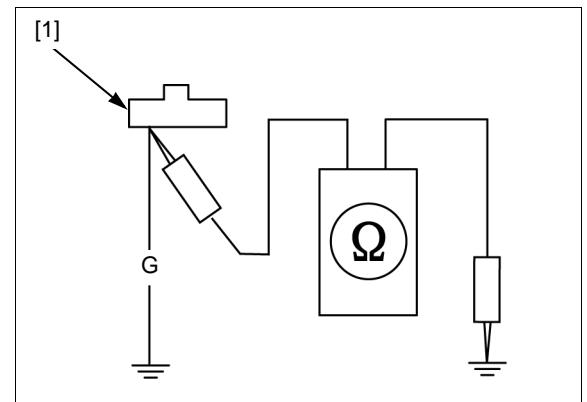

HEADLIGHT/POSITION LIGHT

BULB REPLACEMENT

Remove the two bolts [1] and headlight aim adjusting screw [2].

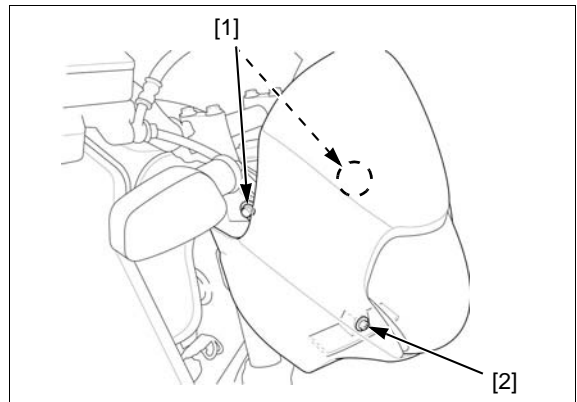

Remove the dust cover [1].
Unhook the bulb retainer [2].
Push the headlight bulb [3] in, turn it counterclockwise and remove it.

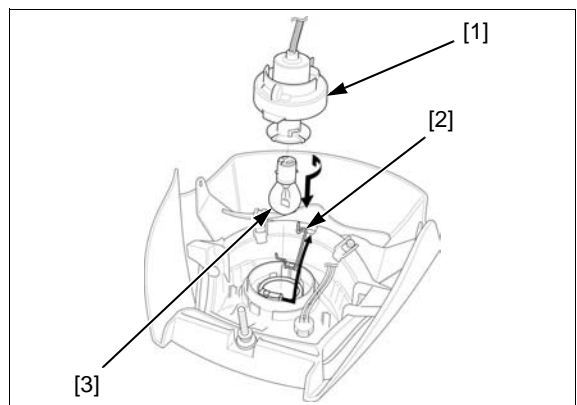

Install the headlight bulb in the reverse order of removal.

Remove the position light bulb socket [1].
Push the position light bulb [2] in, turn it counterclockwise and remove it.
Install the position light bulb in the reverse order of removal.

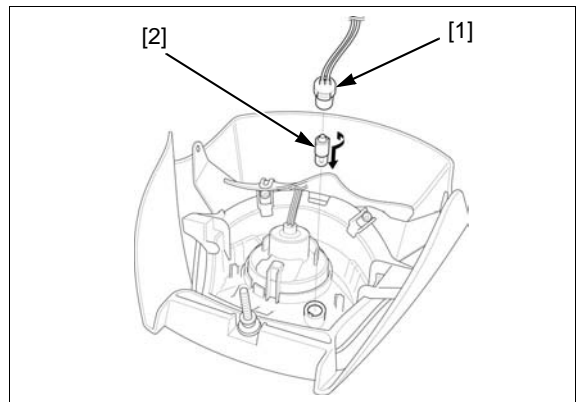

BRAKE/TAIL LIGHT

BULB REPLACEMENT

Remove the screws [1] and the brake/tail light lens [2].
Push the bulb [3] in, turn it counterclockwise and remove it.

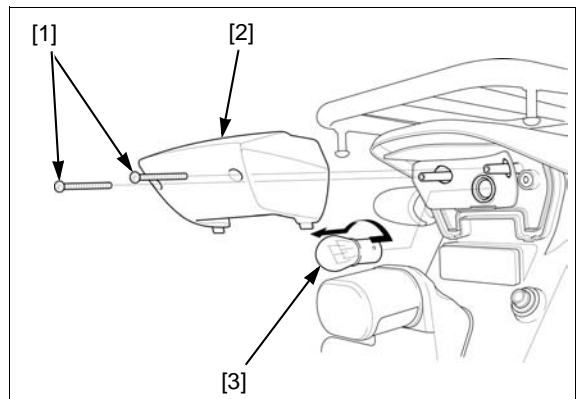

Install the bulb in the reverse order of removal.

LICENSE LIGHT (XR125LK/LEK)

REMOVAL/BULB REPLACEMENT

Remove the nuts [1], collars [2] and license light assembly.

Remove the license light nuts [3], lens cover [4] and lens [5].

Push the bulb [6] in, turn it counterclockwise and remove it.

Install the bulb in the reverse order of removal.

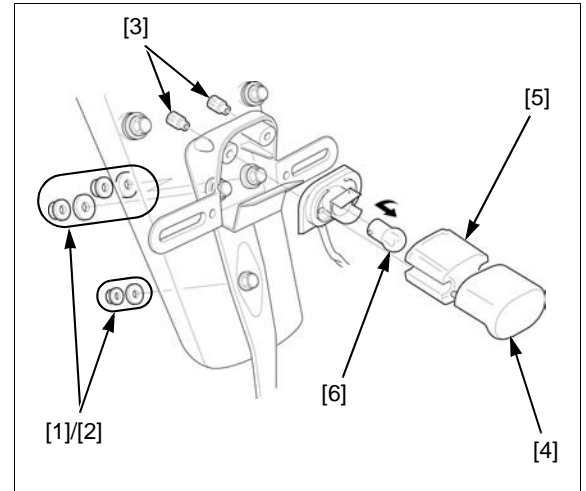

TURN SIGNAL LIGHTS

BULB REPLACEMENT (XR125LK/LEK)

Remove the screw [1] and turn the signal light lens [2].

Pull out the bulb [3] without turning.

Install the bulb in the reverse order of removal.

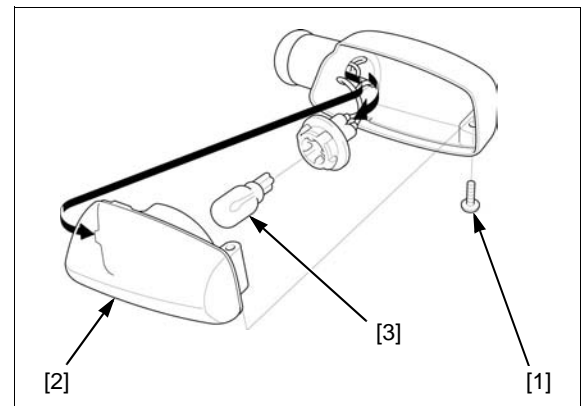

BULB REPLACEMENT (XL125LK)

Remove the screw [1] and turn the signal light lens [2].

Turn the bulb [3] counterclockwise and remove it.

Install the bulb in the reverse order of removal.

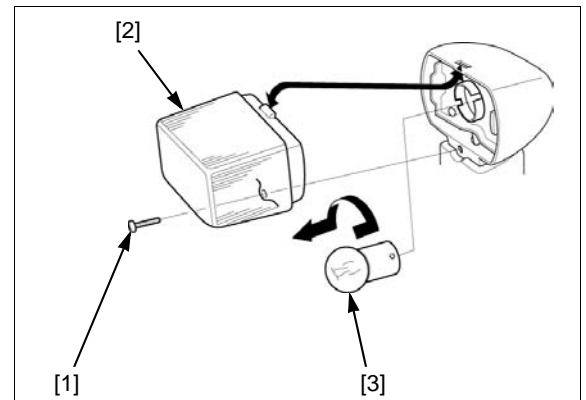

COMBINATION METER

REMOVAL/INSTALLATION

Remove the front visor (page 2-4).

Disconnect the combination meter 9P connector [1].

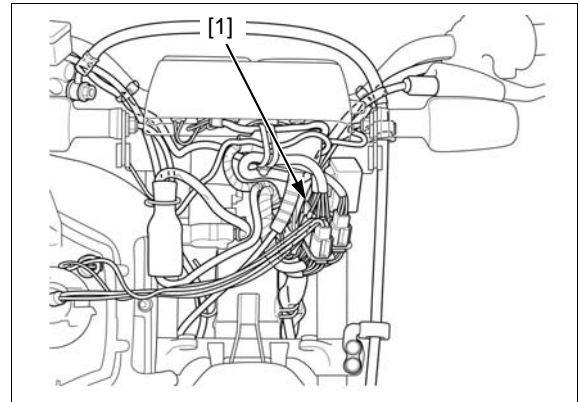

Disconnect the speedometer cable [1].

Remove the nuts [2], washers [3] and combination meter assembly [4].

Installation is in the reverse order of removal.

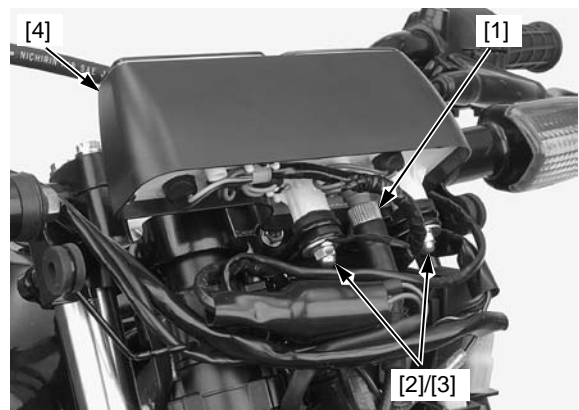

DISASSEMBLY/ASSEMBLY

Disassemble and assemble the combination meter as following illustration.

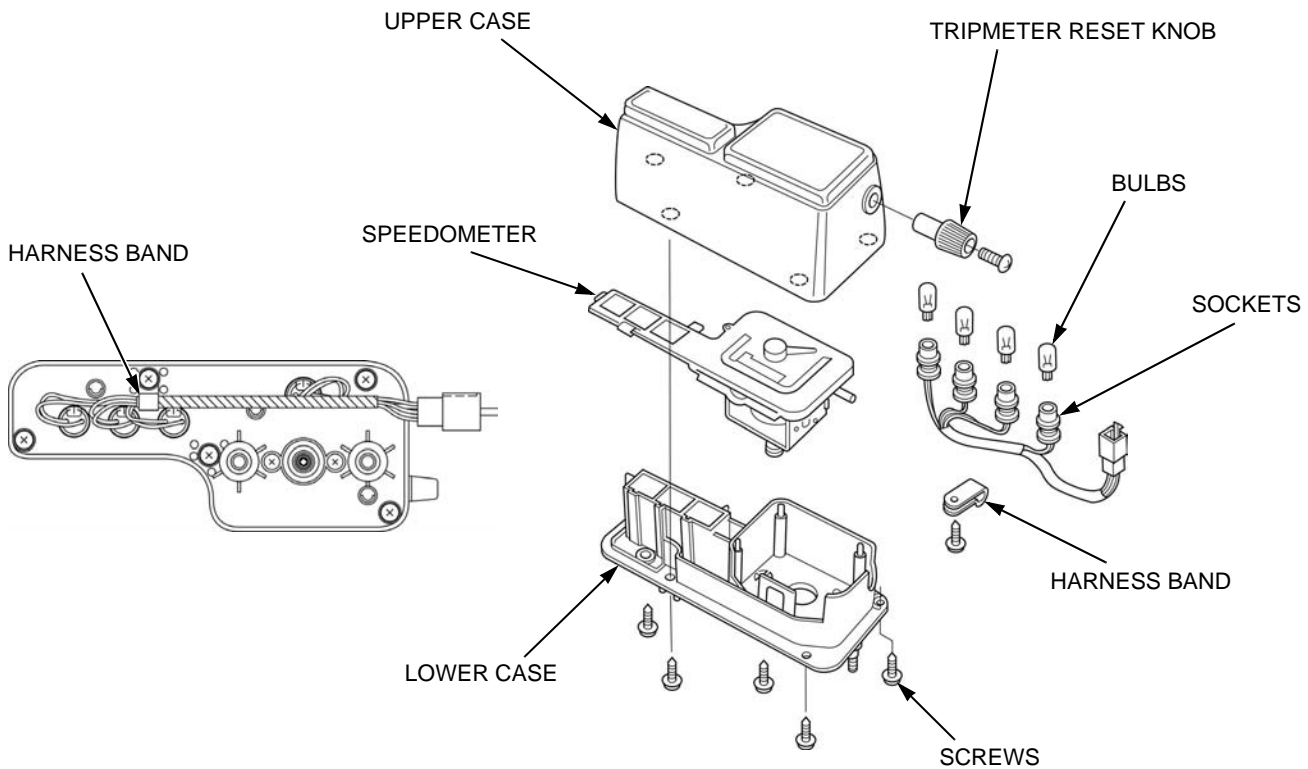

IGNITION SWITCH

INSPECTION

Remove the front visor (page 2-4).

Disconnect the ignition switch 2P connector [1].

Check for continuity between the connector terminals in each switch position according to the chart (page 19-2).

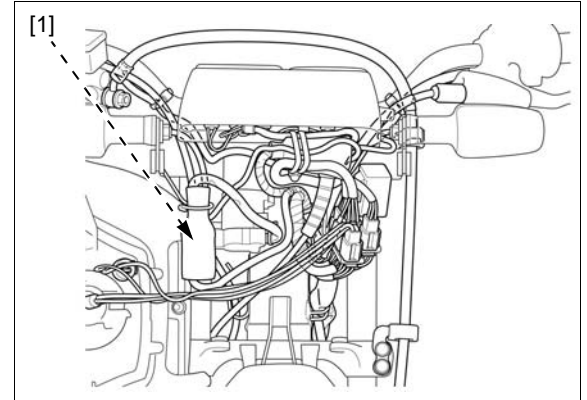

REMOVAL/INSTALLATION

Disconnect the ignition switch connector (page 18-7).

Remove the two mounting bolts [1] and the ignition switch [2].

Install the ignition switch in the reverse order of removal.

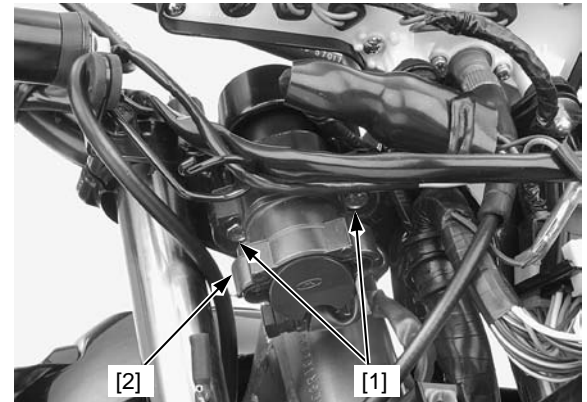

HANDLEBAR SWITCHES

Remove the front visor (page 2-4).

Right handlebar switch: Disconnect the right handlebar switch 6P connector [1].

Left handlebar switch: Disconnect the left handlebar switch 9P (Black) connector [2] and wire connector [3].

Check for continuity between the connector terminals in each switch position according to the chart (page 19-2).

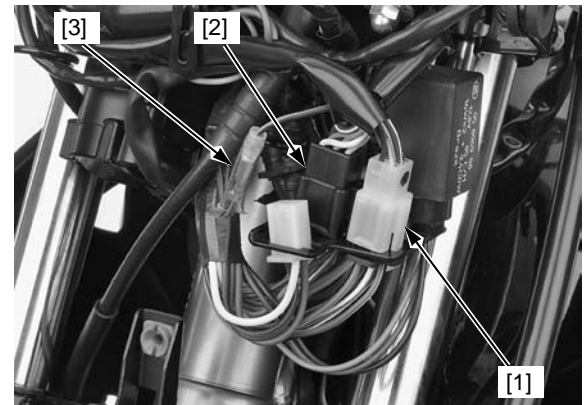

BRAKE LIGHT SWITCHES

FRONT (XR125LK/LEK)

Disconnect the front brake light switch connectors [1].

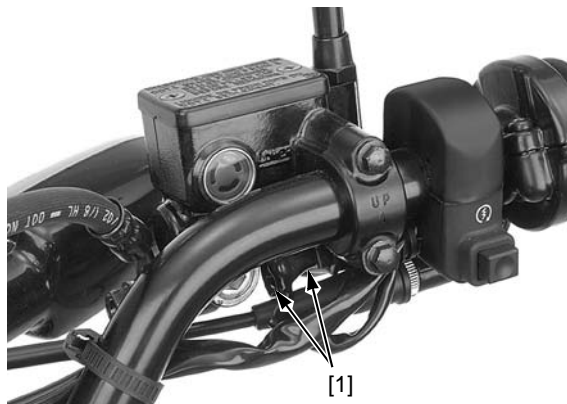

There should be continuity with the brake lever [1] applied, and there should be no continuity when the brake lever is released.



FRONT (XR125LK)

Remove the front visor (page 2-4).

Remove the brake light switch wire connectors [1] from the boot and disconnect them.

There should be continuity with the brake lever applied, and there should be no continuity when the brake lever is released.

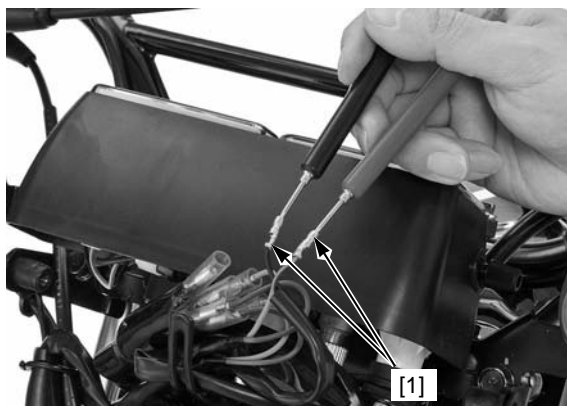

REAR

Remove the left side cover (page 2-2).

Disconnect the rear brake light switch 2P connector [1].

There should be continuity with the brake pedal applied, and there should be no continuity when the brake pedal is released.

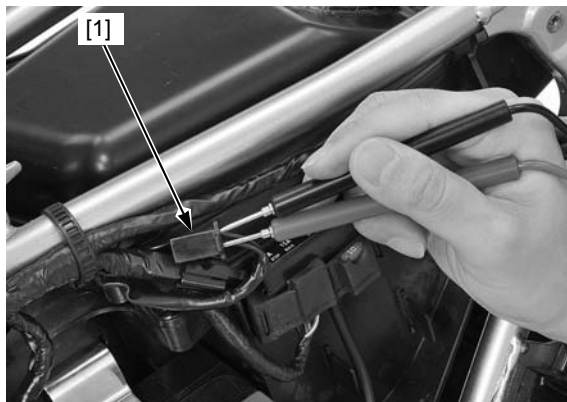

CLUTCH SWITCH

Disconnect the clutch switch connectors [1].

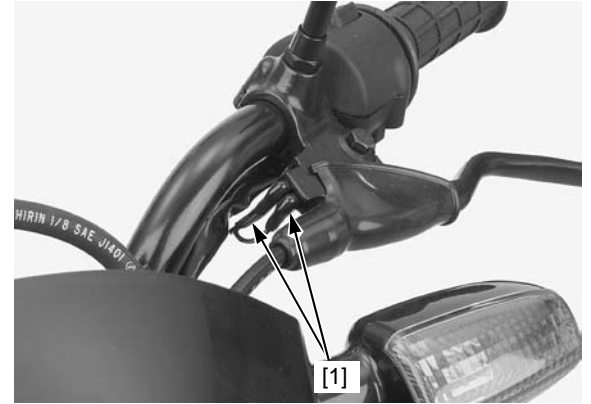

There should be continuity with the clutch lever [1] applied, and there should be no continuity when the clutch lever is released.



NEUTRAL SWITCH

INSPECTION

Remove the right side cover (page 2-2).

Disconnect the neutral switch wire connector [1].

Shift the transmission gear into neutral.

Check for continuity between the Light Green/Red terminal and body ground.

There should be continuity.

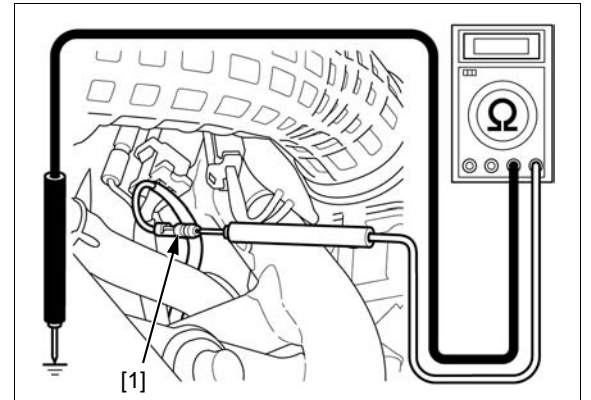

REMOVAL/INSTALLATION

Remove the following:

- Right side cover (page 2-2)
- Drive sprocket cover (page 2-5)

Remove the neutral switch (Light green/red) wire connector [1] from the boot, then disconnect it.

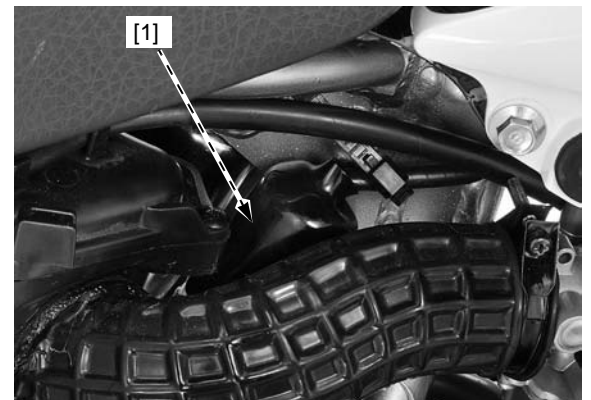

LIGHTS/METER/SWITCHES

Release the neutral switch wire [1] from the ribs on the left crankcase cover.

Remove the bolts [2] and neutral switch [3].

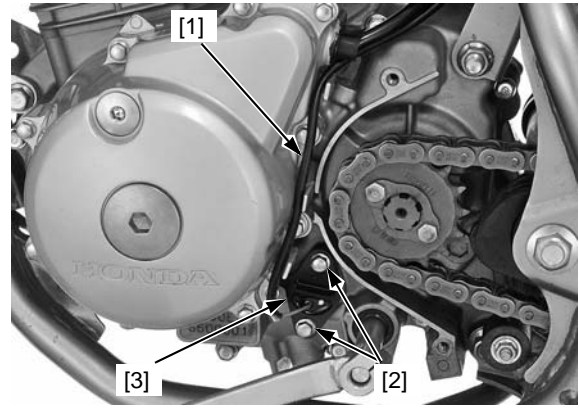

Remove the pin [1] and spring [2] from the shift drum.

Installation is in the reverse order of removal.

- Replace the O-ring [3] with new one.
- Apply engine oil to new O-ring.

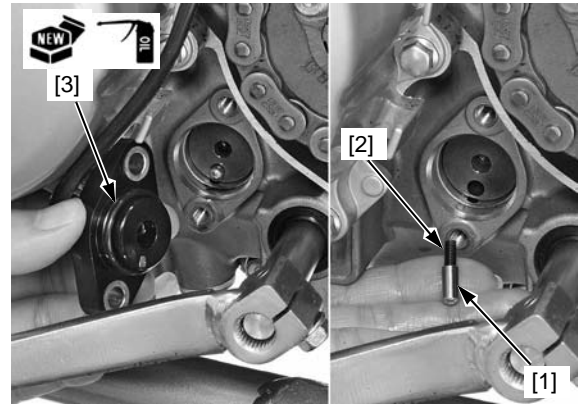

SIDESTAND SWITCH (NZ TYPE)

INSPECTION

Remove the left side cover (page 2-2).

Disconnect the sidestand switch 3P (Green) connector [1] and check for continuity.

There is continuity when the sidestand is raised and there is no continuity when the sidestand is put down.

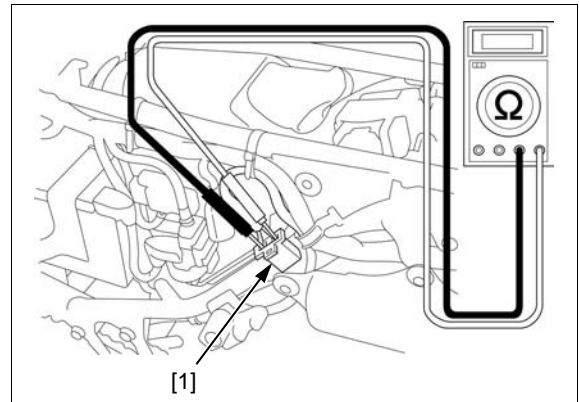

REMOVAL/INSTALLATION

Remove the left side cover (page 2-2).

Disconnect the sidestand 3P connector.

Remove the bolts [1] and sidestand switch cover [2].

Remove the sidestand switch bolt [3] and sidestand switch [4].

Installation is in the reverse order of removal.

- At sidestand switch installation, align the pin on the switch with the hole in the sidestand.
- At sidestand switch installation, align the groove on the switch with the pin on the sidestand bracket.

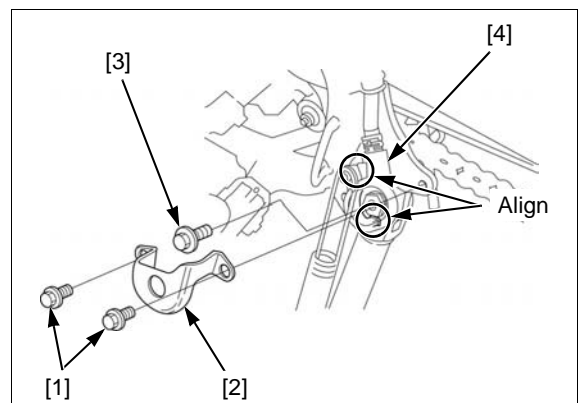

TURN SIGNAL RELAY

INSPECTION

1. Recommended Inspection

Check the following:

- Battery condition
- Burned out bulb or non-specified wattage
- Burned fuse
- Ignition switch and turn signal switch function
- Loose connector

Check for the above items.

Are the above items in good condition?

NO – Replace or repair the malfunction part(s)

YES – GO TO STEP 2.

2. Turn Signal Circuit Inspection

Remove the front visor (page 2-4).

Disconnect the 3P (Black) connector [1] from the turn signal relay [2].

Short the Black/brown and Gray terminals of the turn signal relay connector with a jumper wire. Start the engine and check the turn signal light by turning the switch ON.

Is the light come on?

- YES** –
- Faulty turn signal relay
 - Poor connection of the connector.

NO – Broken wire harness

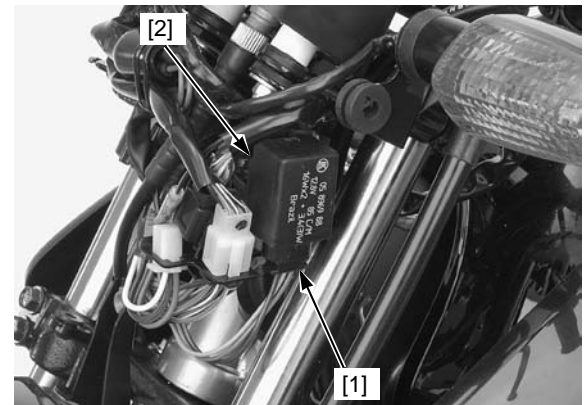

HORN

REMOVAL/INSTALLATION

Disconnect the connectors [1] from the horn [2]. Remove the bolt [3] and horn.

Installation is in the reverse order of removal.

INSPECTION

Disconnect the wire connectors from the horn.

Connect the 12 V battery to the horn terminals.

The horn is normal if it sounds when the battery is connected across the horn terminals.

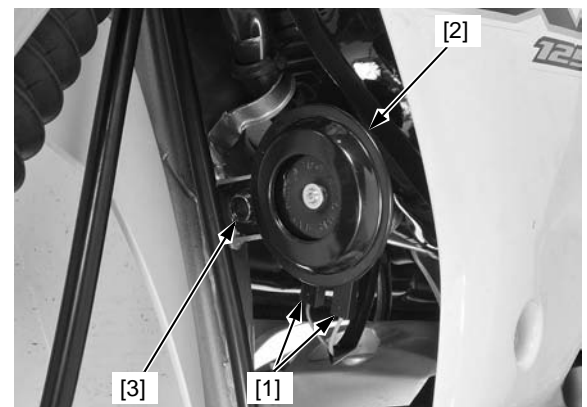

MEMO

19. WIRING DIAGRAMS

XR125LEK (DK, I LA TYPES).....	19-2	XR125LK (DK TYPE)	19-5
XR125LEK (III LA, CO TYPES).....	19-3	XR125LK (III LA TYPE)	19-6
XR125LEK (NZ TYPE)	19-4	XL125LK	19-7

WIRING DIAGRAMS

XR125LEK (DK, I LA TYPES)

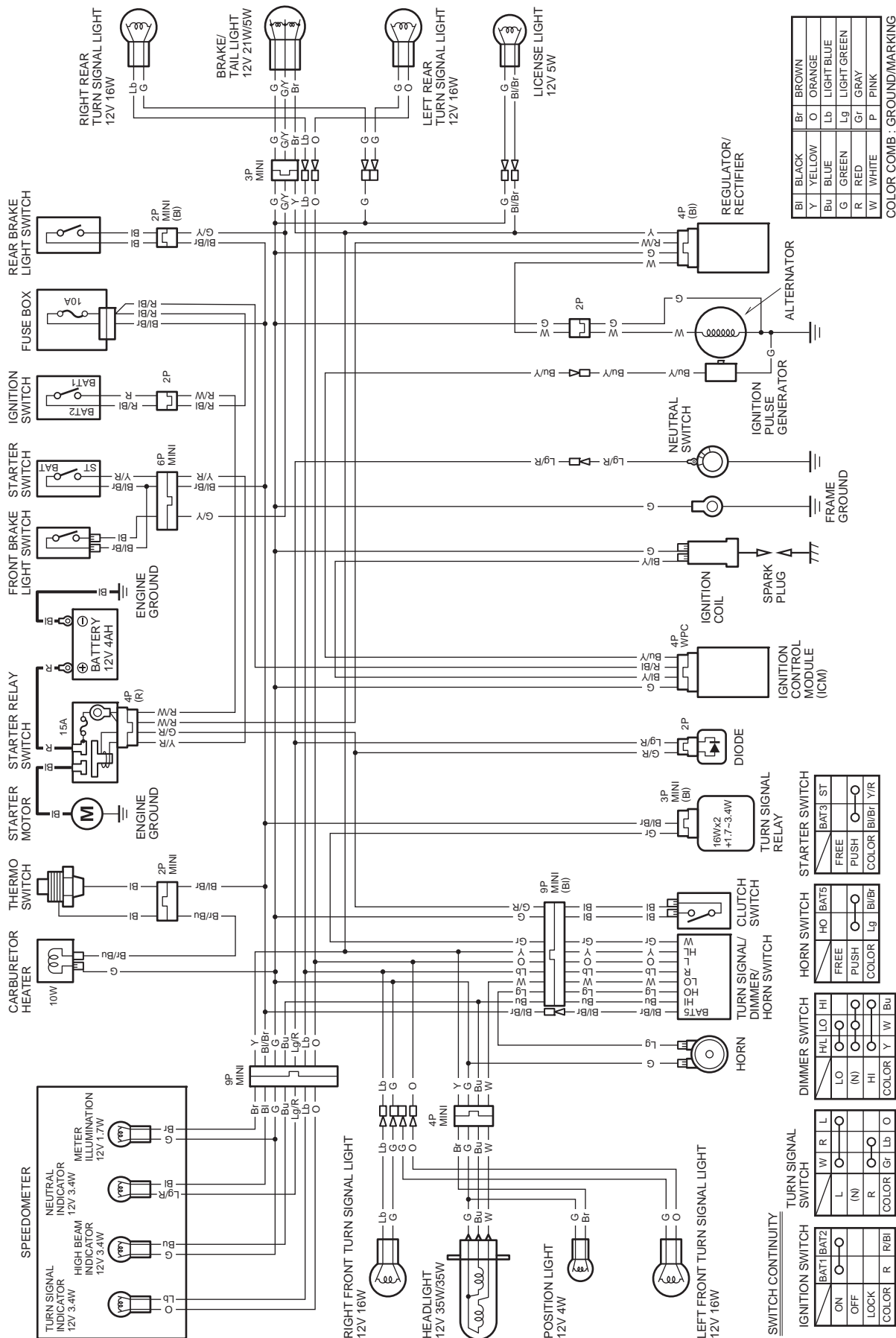

XR125LEK (III LA, CO TYPES)

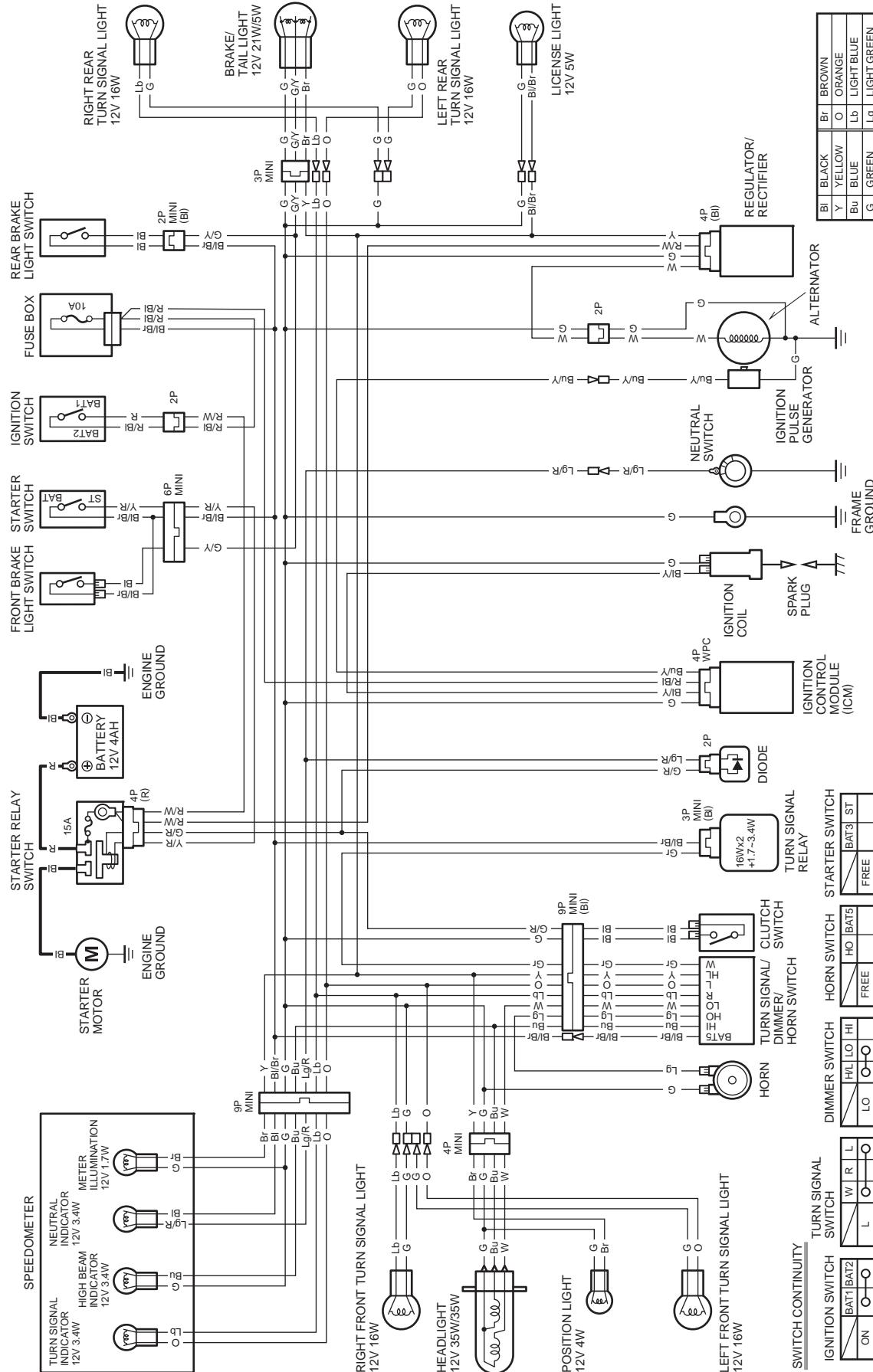

Bl	Black	Br	Brown
Y	Yellow	O	Orange
Bu	Blue	Lb	Light Blue
G	Green	Lg	Light Green
R	Red	Gr	Gray
W	White	P	Pink

COLOR COMB : GROUND/MARKING

BAT3	ST		
FREE	PUSH	○	○
COLOR	Bl/Br	Y/R	

HO	BAT5		
FREE	PUSH	○	○
COLOR	Lg	Bl/Br	

H/L	LO	HI	
○	○	○	○
COLOR	Y	W	Blu

W	R	L	
○	○	○	○
COLOR	G	Lb	O

BAT1	BAT2		
ON	OFF	○	○
COLOR	R	R/Bl	

WIRING DIAGRAMS

XR125LEK (NZ TYPE)

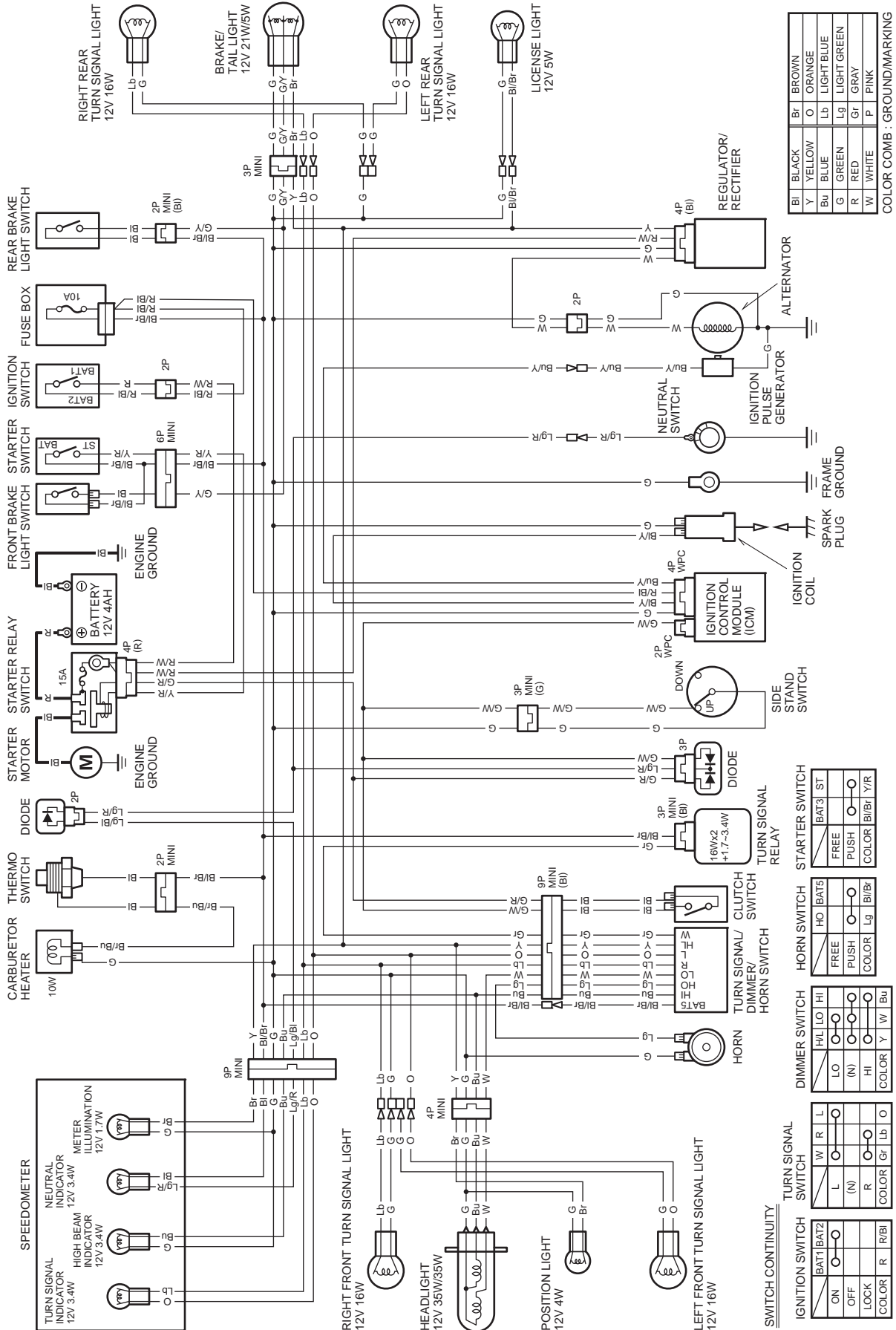

XR125LK (DK TYPE)

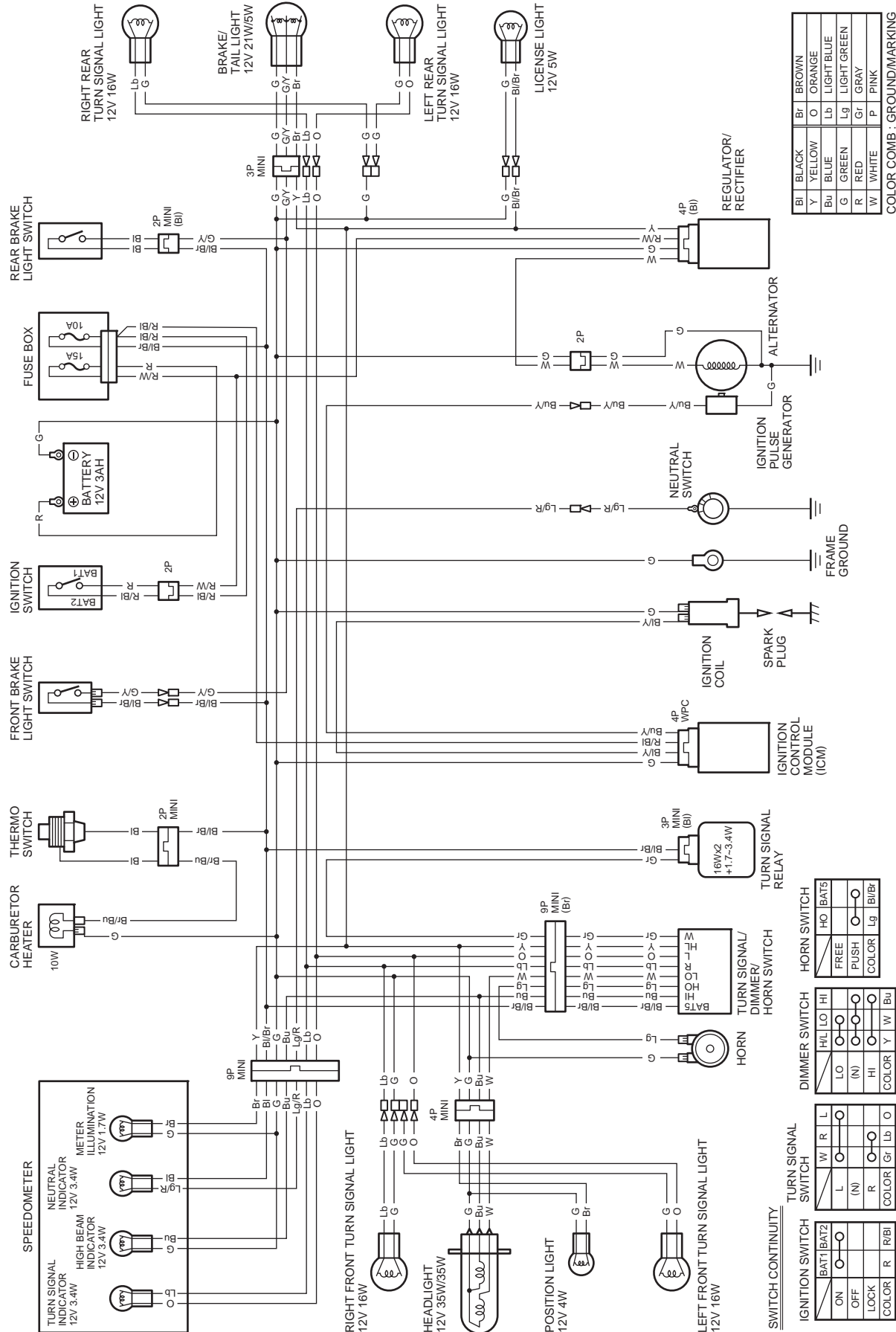

Bl	Black	Br	Brown
Y	Yellow	O	Orange
Bu	Blue	Lb	Light Blue
G	Green	Lg	Light Green
R	Red	Gr	Gray
W	White	P	Pink

COLOR COMB : GROUND/MARKING

HO	BAT5
FREE	PUSH
COLOR	Lg
	Bl/Br

H/L	LO	HI
LO	(N)	HI
COLOR	Y	W
	Bl	Bu

BAT1	BAT2
ON	OFF
LOCK	
COLOR	R
	Bl/Br

W	R	L
L	(N)	R
COLOR	G	Lb
	O	

WIRING DIAGRAMS

XR125LK (III LA TYPE)

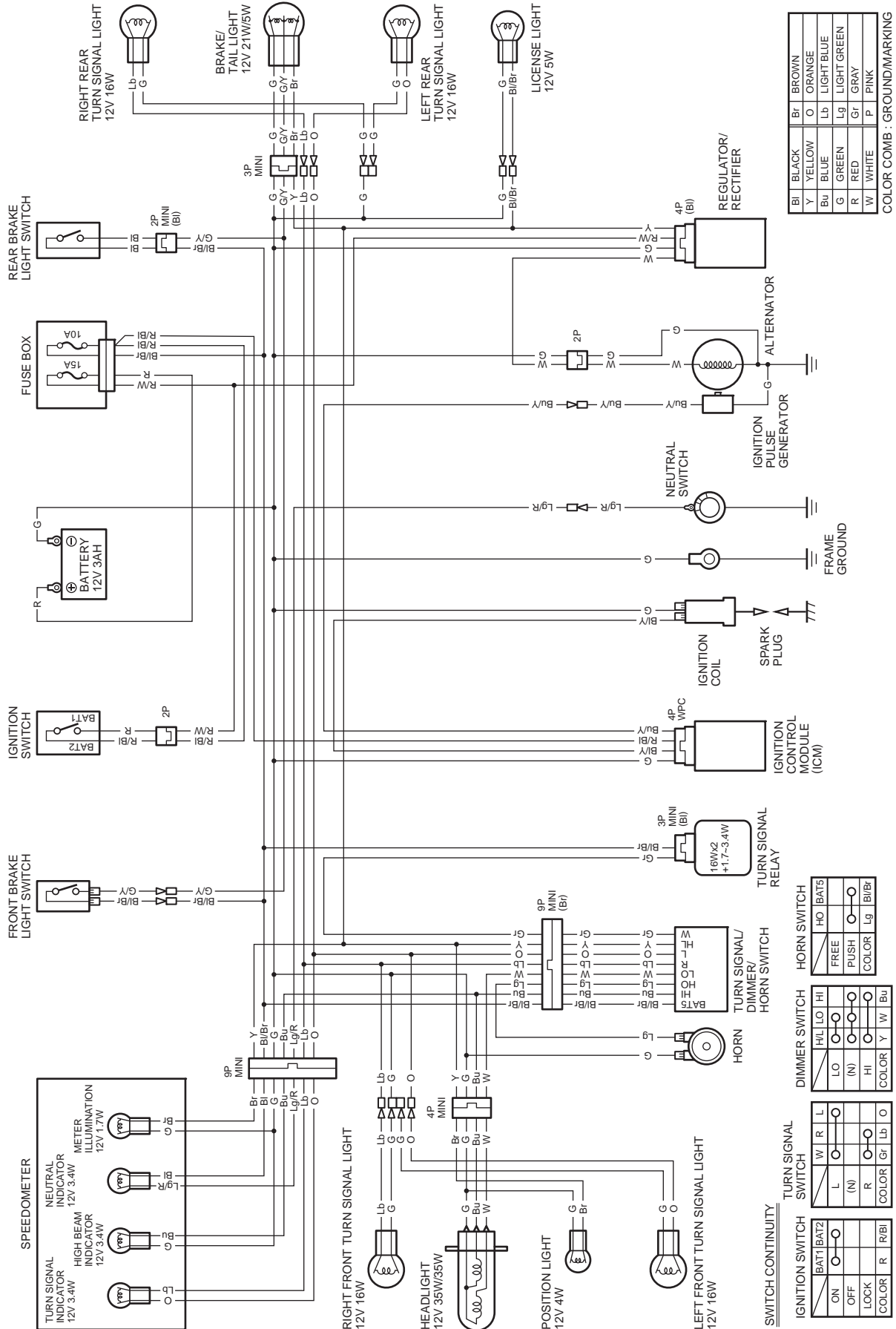

XL125LK

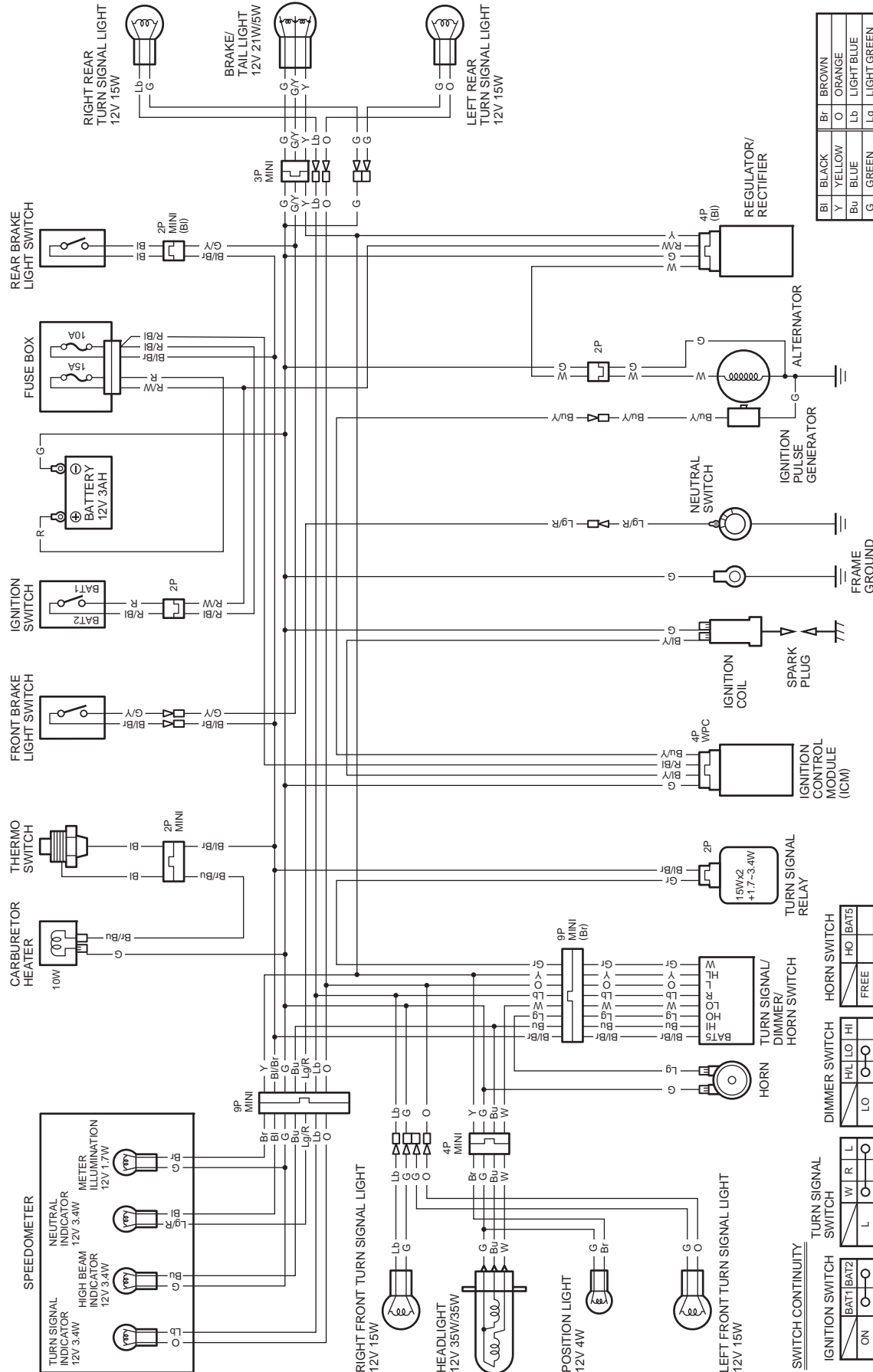

Bl	Black	Br	Brown
Y	Yellow	O	Orange
Bu	Blue	Lb	Light Blue
G	Green	Lg	Light Green
R	Red	Gr	Gray
W	White	P	Pink

COLOR COMB : GROUND/MARKING

HO	BAT5
FREE	PUSH
COLOR	Lg
	Bl/Br

H/L	LO	H
LO	(N)	O
COLOR	Y	W
	Lb	O

BAT1	BAT2
ON	OFF
LOCK	
COLOR	R
	R

W	R	L
L	(N)	O
COLOR	G	Lb
	O	

MEMO

INDEX

AIR CLEANER	3-4	IGNITION SYSTEM INSPECTION	4-4
AIR CLEANER HOUSING	6-4	IGNITION TIMING	4-5
AIR CLEANER SUB FILTER (XR125LK/LEK)	3-4	KICKSTARTER	12-15
ALTERNATOR CHARGING COIL	17-7	KICKSTARTER IDLE GEAR	12-14
BATTERY	17-5	LEFT CRANKCASE COVER	11-3
BRAKE CALIPER	16-9	LICENSE LIGHT (XR125LK/LEK)	18-5
BRAKE FLUID (XR125LK/LEK)	3-12	LIGHTING SYSTEM INSPECTION	18-3
BRAKE FLUID REPLACEMENT/AIR BLEEDING	16-4	LUBRICATION & SEAL POINTS	1-14
BRAKE LIGHT SWITCH	3-14	LUBRICATION SYSTEM DIAGRAM	7-2
BRAKE LIGHT SWITCHES	18-8	MAINTENANCE SCHEDULE	3-2
BRAKE PAD/DISC	16-6	MASTER CYLINDER	16-7
BRAKE PEDAL	15-9	MODEL IDENTIFICATION	1-2
BRAKE SHOE/PAD WEAR	3-12	NEUTRAL DIODE	5-8
BRAKE SYSTEM	3-13	NEUTRAL SWITCH	18-9
BRAKE/TAIL LIGHT	18-4	NUMBER PLATE BRACKET	2-3
CABLE & HARNESS ROUTING		NUTS, BOLTS, FASTENERS	3-16
XL125LK	1-24	OIL PUMP	7-3
XR125LK/LEK	1-16	PILOT SCREW ADJUSTMENT	6-12
CAM CHAIN TENSIONER LIFTER	8-17	PISTON	9-5
CAMSHAFT	8-5	PRIMARY DRIVE GEAR	10-13
CAMSHAFT HOLDER	8-8	REAR CARRIER	2-2
CARBURETOR	6-5	REAR COWL	2-3
CARBURETOR HEATER (EXCEPT CO, III LA TYPES) ..	6-10	REAR DRUM BRAKE	15-7
CHARGING SYSTEM INSPECTION	17-6	REAR WHEEL	15-4
CLUTCH	10-7	REGULATOR/RECTIFIER	17-7
CLUTCH SWITCH	18-9	RIGHT CRANKCASE COVER	10-4
CLUTCH SYSTEM	3-15	SEAT	2-2
COMBINATION METER	18-6	SECONDARY AIR SUPPLY SYSTEM (XR125LK/LEK)	
COMPONENT LOCATION		FUEL SYSTEM	6-13
BATTERY/CHARGING SYSTEM	17-2	MAINTENANCE	3-9
ELECTRIC STARTER	5-2	SERVICE INFORMATION	
IGNITION SYSTEM	4-2	BATTERY/CHARGING SYSTEM	17-3
LIGHTS/METER/SWITCHES	18-2	CLUTCH/GEARSHIFT LINKAGE/KICKSTARTER ..	10-3
CRANKCASE BREATHER	3-5	CRANKCASE/CRANKSHAFT/TRANSMISSION	12-3
CRANKCASE SEPARATION/ASSEMBLY	12-4	CYLINDER HEAD/VALVES	8-2
CRANKSHAFT	12-13	CYLINDER/PISTON	9-3
CYLINDER	9-4	ELECTRIC STARTER	5-3
CYLINDER COMPRESSION	8-3	ENGINE REMOVAL/INSTALLATION	13-2
CYLINDER HEAD	8-11	FRONT WHEEL/SUSPENSION/STEERING	14-3
CYLINDER HEAD COVER	8-4	FUEL SYSTEM	6-2
DRIVE CHAIN	3-9	HYDRAULIC BRAKE	16-3
DRIVE CHAIN SLIDER	3-11	IGNITION SYSTEM	4-3
DRIVE SPROCKET COVER	2-5	LIGHTS/METER/SWITCHES	18-2
EMISSION CONTROL SYSTEMS	1-30	LUBRICATION SYSTEM	7-3
ENGINE IDLE SPEED	3-8	REAR WHEEL/BRAKE/SUSPENSION	15-3
ENGINE INSTALLATION	13-5	SERVICE RULES	1-2
ENGINE OIL	3-7	SHOCK ABSORBER	15-11
ENGINE OIL CENTRIFUGAL FILTER	3-8	SIDE COVER	2-2
ENGINE OIL STRAINER SCREEN	3-7	SIDE SHROUD	2-4
ENGINE REMOVAL	13-3	SIDESTAND	3-16
EXHAUST PIPE/MUFFLER	2-6	SIDESTAND SWITCH (NZ TYPE)	18-10
FLYWHEEL/STARTER CLUTCH	11-4	SPARK PLUG	3-5
FORK	14-13	SPECIFICATIONS	1-3
FRONT DRUM BRAKE (XL125LK)	14-13	STARTER MOTOR	5-5
FRONT FENDER	2-5	STARTER RELAY	5-7
FRONT VISOR	2-4	STATOR/IGNITION PULSE GENERATOR	11-4
FRONT WHEEL	14-9	STEERING HEAD BEARINGS	3-17
FUEL STRAINER SCREEN	3-3	STEERING STEM	14-22
FUEL TANK	2-4	SUSPENSION	3-16
GEARSHIFT LINKAGE	10-10	SWINGARM	15-13
HANDLEBAR	14-4	SYSTEM COMPONENTS	
HANDLEBAR SWITCHES	18-7	ALTERNATOR/STARTER CLUTCH	11-2
HEADLIGHT AIM	3-15	CLUTCH/GEARSHIFT LINKAGE/KICKSTARTER ..	10-2
HEADLIGHT/POSITION LIGHT	18-4	CRANKCASE/CRANKSHAFT/TRANSMISSION	12-2
HORN	18-11	CYLINDER HEAD/VALVES	8-2
ICM (IGNITION CONTROL MODULE)	4-6	CYLINDER/PISTON	9-2
IGNITION COIL	4-6	ENGINE REMOVAL/INSTALLATION	13-2
IGNITION SWITCH	18-7	FRONT WHEEL/SUSPENSION/STEERING	14-2
		FUEL SYSTEM	6-2

INDEX

HYDRAULIC BRAKE	16-2	FRONT WHEEL/SUSPENSION/STEERING	14-3
REAR WHEEL/BRAKE/SUSPENSION	15-2	FUEL SYSTEM	6-3
SYSTEM DIAGRAM		HYDRAULIC BRAKE	16-3
BATTERY/CHARGING SYSTEM	17-2	IGNITION SYSTEM.....	4-3
ELECTRIC STARTER	5-2	LUBRICATION SYSTEM	7-3
IGNITION SYSTEM	4-2	REAR WHEEL/BRAKE/SUSPENSION	15-3
THROTTLE OPERATION	3-3	TURN SIGNAL LIGHTS.....	18-5
TORQUE VALUES.....	1-10	TURN SIGNAL RELAY	18-11
TRANSMISSION	12-8	VALVE CLEARANCE	3-6
TROUBLESHOOTING		WHEELS/TIRES	3-16
ALTERNATOR/STARTER CLUTCH	11-2	WIRING DIAGRAMS	
BATTERY/CHARGING SYSTEM	17-4	XL125LK.....	19-7
CLUTCH/GEARSHIFT LINKAGE/KICKSTARTER..	10-3	XR125LEK (DK, I LA TYPES)	19-2
CRANKCASE/CRANKSHAFT/TRANSMISSION.....	12-3	XR125LEK (III LA, CO TYPES).....	19-3
CYLINDER HEAD/VALVES.....	8-3	XR125LEK (NZ TYPE)	19-4
CYLINDER/PISTON	9-3	XR125LK (DK TYPE)	19-5
ELECTRIC STARTER	5-3	XR125LK (III LA TYPE).....	19-6
